

Transfer of nuclear technology to

Saudi Arabia

by

Tawfik Ahmed Kusayer

A Thesis Submitted to the  
Graduate Faculty in Partial Fulfillment of  
The Requirements for the Degree of  
MASTER OF SCIENCE

Major: Nuclear Engineering

---

Signatures have been redacted for privacy

Iowa State University  
Ames, Iowa

1978

Copyright © Tawfik Ahmed Kusayer, 1978. All rights reserved.

©1978  
TAWFIK AHMED KUSAYER  
All Rights Reserved



## TABLE OF CONTENTS

	Page
ACKNOWLEDGMENTS	xiv
ABSTRACT	xv
1. INTRODUCTION	1
2. FACTORS IN TRANSFER OF TECHNOLOGY	5
2.1. The Ideological Factor	5
2.1.1. Present trends	5
2.1.2. Hypotheses	6
2.1.3. Local ideology	7
2.1.4. Attitude towards work and labor	7
2.1.5. Dedication	8
2.1.6. Quality	8
2.1.7. Conservation	9
2.1.8. Safety	9
2.1.9. Environment and ecology protection	9
2.1.10. Productivity	10
2.1.11. Competition	11
2.1.12. Stability	11
2.1.13. Adoption and adaption	12
2.1.14. Basic differences between Islam and technological ideologies	13
2.1.15. Test of hypotheses	15
2.2. Social and Cultural Factors	17
2.2.1. Life style	18
2.2.2. Social change	20
2.2.3. Effect of nonindigent cultures	22
2.2.4. Attitude towards work	23
2.2.5. Attitude towards technology	23
2.2.6. Attitude towards labor	24
2.2.7. Attitude towards nuclear energy	25
2.3. Human Factors	31
2.3.1. Quality control	31
2.3.2. Safety	32
2.3.3. Training	33
2.3.4. Research and development	36

	Page
2.4. Economic Factors	37
2.5. Summary	38
3. STRATEGY FOR TRANSFER OF NUCLEAR TECHNOLOGY	40
3.1. General Principles	40
3.1.1. Framework	40
3.1.2. Human capital	41
3.1.3. Planning	42
3.1.4. Communication	43
3.1.5. Financial risk	43
3.1.6. Evolution	44
3.1.7. System	46
3.2. The Saudi Arabian Case	46
3.3. Objective	47
3.4. Proposed Plan Layout	48
3.4.1. Central transfer of nuclear technology committee	49
3.4.2. Training programs	50
3.4.3. Research and development establishment	52
3.4.4. Information centers	53
3.4.5. Higher education	55
3.4.6. International activities	56
3.5. Evaluation of Objective and Strategy	57
3.5.1. Achievement probability	57
3.5.2. Impact of power production on living standards	60
3.5.3. Measure of effectiveness	63
3.5.4. Test of alternate strategies	64
4. ALTERNATE METHODS TO REALIZE TRANSFER OF NUCLEAR TECHNOLOGY GOALS	75
4.1. Measures of Effectiveness	76
4.2. Assessment of Component Utility Function	79
4.3. Scaling Factors	105
4.3.1. Scaling of attributes, $k_i$	105
4.3.2. Utility scaling, $K$	112

	Page
4.4. Evaluation of Alternatives	113
5. MODELING OF VARIOUS MODES AND PHASES OF TECHNOLOGY TRANSFER	117
5.1. Domain of Transfer	117
5.2. Available Models	118
5.3. Topological Models	121
5.3.1. Temporal model	121
5.3.2. Internal processes	123
5.3.3. Stationary model	127
5.4. Probabilistic Models	131
5.4.1. Sequential probabilistic model	131
5.4.2. Flow block diagrams	133
5.4.3. Logic tree model	135
5.4.4. Flow process tree	140
5.4.5. Event or decision tree model	140
5.4.6. Cause-effect matrix	143
5.5. Deterministic Models	146
5.5.1. Functional model	146
5.5.2. Flow diagrams	147
5.6. Statistical Models	154
5.6.1. Diffusion model	154
5.6.2. Cybernetic model	159
6. MONITORING OUTCOMES OF TRANSFER OF NUCLEAR TECHNOLOGY	162
6.1. Progress and Technical Advances	162
6.2. Model	163
6.3. Uses of the Model	171
6.4. Application of the Model	173
6.4.1. Objective	173
6.4.2. The approach	174

	Page
6.4.3. Initial conditions and state variable definitions	178
6.4.4. The SAINT model	180
6.4.5. Model input	191
6.4.6. Model output	206
7. CONCLUSIONS AND RECOMMENDATIONS	213
8. REFERENCES	216
9. APPENDIX A: SURVEY	220
9.1. SAS Computer Program	220
9.2. Questionnaire	222
9.3. Results	226
9.4. Analysis	235
9.5. Cross Examination of Survey Response	275
10. APPENDIX B: UTILITY PROGRAMS	286
11. APPENDIX C: SAINT PROGRAM	291
11.1. The Main Program	291
11.2. State Variable Table for Iteration Number 1	296
11.3. Detailed Output of Iteration Number 1	316

## LIST OF TABLES

	Page
Table 2.1. Attitude towards nuclear technology as function of familiarity with nuclear energy	27
Table 2.2. Educational level of people surveyed	29
Table 2.3. Extreme responses	30
Table 2.4. Economic factor in the preference pattern	30
Table 2.5. Preference pattern for construction of one large nuclear plant in Saudi Arabia	31
Table 3.1. Truth table and probability of partial or total achievement of the objective to build 3 nuclear power stations by the year 2000 in Saudi Arabia	59
Table 3.2. Average annual income and electric energy consumption in selected countries (1976)	61
Table 3.3. Alternate strategies for transfer of nuclear technology	66
Table 3.4. Decision points of Figure 3.3 for alternate strategies for transfer of nuclear technology to Saudi Arabia; target date 2000	68
Table 3.5. Basic probabilities used in computation of outcomes of each alternate strategy (Figure 3.3) for power production in Saudi Arabia, target date 2000	70
Table 3.6. Outcomes of alternate strategies for nuclear technology transfer to Saudi Arabia, target year 2000 (Figure 3.3)	71
Table 3.7. The outcome of each alternate strategy for nuclear technology transfer to Saudi Arabia, target date 2000	73



	Page
Table 4.1. Relative range of various attributes of transferring nuclear technology	77
Table 4.2. Coefficients of the component utility function ( $U = A + Be^{CX}$ )	81
Table 4.3. The meaning of the symbols used for scaling factor lotteries	112
Table 4.4. Attribute levels for alternative systems	115
Table 4.5. Utility values of the alternatives	116
Table 5.1. Types and components of transfer of technology processes	120
Table 5.2. Successful and unsuccessful transfer of technology in terms of the topology model	127
Table 5.3. Events and associated probabilities leading to introduction of a new product in the market by a specific organization	132
Table 5.4. Variables of the functional transfer model in the planning, utility and business sectors in Saudi Arabia	148
Table 6.1. Control strategy for nuclear technology transferring model	176
Table 6.2. Initial conditions and corresponding SAINT variables employed in the transferring model	179
Table 6.3. Task description codes	186

## LIST OF FIGURES

	Page
Figure 3.1. Dependence of GNP on power consumption	62
Figure 3.2. Utility function of annual per capita income for Saudi Arabia	65
Figure 3.3. Decision tree for choice of alternate strategies of transfer of nuclear technology to Saudi Arabia, target date 2000	67
Figure 4.1. Component utility function for time required for whole project to be done (years)	82
Figure 4.2. Component utility function for performance of training program (person per year)	83
Figure 4.3. Component utility function for industrialization of the country (subjective)	84
Figure 4.4. Component utility function for research encouragement (subjective)	85
Figure 4.5. Component utility function for innovation enhancement (subjective)	86
Figure 4.6. Component utility function for increase in project cost over similar project in nuclear countries (percentage)	87
Figure 4.7. Component utility function for outside control (percentage)	88
Figure 4.8. Component utility function for long term benefits for development (subjective)	89
Figure 4.9. Component utility function for probability of success in achieving the goal (probability)	90
Figure 4.10. Component utility function for harmony with ideology (subjective)	91
Figure 4.11. Component utility function for compatibility with culture (subjective)	92

	Page
Figure 4.12. Component utility function for safety (probability)	93
Figure 4.13. Component utility function for quality (subjective)	94
Figure 4.14. Component utility function for assurance of fuel supply (percentage)	95
Figure 4.15. Component utility function for spin-offs (subjective)	96
Figure 4.16. Component utility function for increase in GNP (percentage per year)	97
Figure 4.17. Component utility function for agreeability with public attitude (subjective)	98
Figure 4.18. Component utility function for preference of decision-maker (subjective)	99
Figure 4.19. Component utility function for international participation (man per millions (\$))	100
Figure 4.20. Component utility function for R&D cost effectiveness (percentage)	101
Figure 4.21. Component utility function for diversion potential (percentage)	102
Figure 4.22. Component utility function for vulnerability to sabotage (percentage)	103
Figure 4.23. General types of utility curves (21)	104
Figure 4.24. Lotteries for determining the component scaling factors, $k_i$	107
Figure 5.1. Simple transfer of technology model	119
Figure 5.2. Topology of science-technology-use streams and communication paths	122
Figure 5.3. Interrelationships among science, technology, and industry (27)	124



	Page
Figure 5.4a. Evaluation of a particular area of science (27)	125
Figure 5.4b. Evaluation of particular technology (27)	125
Figure 5.4c. Evaluation of a specific productivity industry (27)	125
Figure 5.5. Model of interrelationships between the three domains: (A) plasma physics and related sciences, (B) fusion technology and (C) fusion power plant utilization (28)	128
Figure 5.6. Important communication paths between fusion and other fields: A, B and C are as in Fig. 5.5, (D) Science, (E) Technology and (F) utilization (28)	129
Figure 5.7. Important communication paths between developed, developing and underdeveloped countries in plasma physics (A), Fusion technology (B) and Power plant use (C). Subscripts D and U refer to developing and underdeveloped countries, respectively (28)	130
Figure 5.8. Flow block diagram for sequential probabilistic model	134
Figure 5.9. Flow block diagram of transfer of nuclear technology from concepts to power market	136
Figure 5.10. Probabilities for series and parallel flow block diagrams	137
Figure 5.11. Symbols for logic tree model	138
Figure 5.12. Logic tree for transfer of nuclear technology to developing countries	139
Figure 5.13. Flow process tree model of transfer of nuclear technology to Saudi Arabia	141

	Page
Figure 5.14. Event tree for nuclear technology transfer	142
Figure 5.15. Cause-effect matrix	144
Figure 5.16. Reordered cause-effect matrix	145
Figure 5.17. A model of the interest/relevance perimeter of the technology (30)	150
Figure 5.18. Modification of the company-technology relationship (30)	151
Figure 5.19. A model for technical activity	152
Figure 5.20. A four-stage process of technical advance (30)	153
Figure 5.21. Technical advance (at a microlevel) related to demand-technical feasibility fusion (32)	155
Figure 5.22. Cybernetic model	161
Figure 6.1. Progress-advancement model of a recipient, R	164
Figure 6.2. Progress-advancement model of a recipient R relative to a source, S	166
Figure 6.3. Representation of rates of change in the velocity space	169
Figure 6.4. Transfer of technology plan review and control	172
Figure 6.5. Range of angle $\theta$	175
Figure 6.6. Range of distance r	175
Figure 6.7. State variable network model of transferring process	181
Figure 6.8. Symbols used for the state variables equations	182

	Page
Figure 6.9. Symbols for monitored variables and monitor action	183
Figure 6.10. Subroutine STATE for the transferring model	184
Figure 6.11. Subroutine INTLC for the transferring model	185
Figure 6.12. Task network model of transferring process	187
Figure 6.13. General representation of a SAINT task	188
Figure 6.14. Summary of initial SAINT modeling concepts	188
Figure 6.15. SAINT model illustrating tasks and precedence relations	190
Figure 6.16. SAINT input data for the transferring model	192
Figure 6.17. Echo check-run parameters, program options, and output options	196
Figure 6.18. Echo check-task definitions	197
Figure 6.19. Echo check-attribute assignment information	198
Figure 6.20. Echo check-deterministic branching	199
Figure 6.21. Echo check-conditional branching	200
Figure 6.22. Echo check-state variable general information and state variable descriptions	201
Figure 6.23. Echo check-state variable regulation caused by task completions	202
Figure 6.24. Echo check-state variable monitors	203
Figure 6.25. Echo check-task signaling and switching caused by monitor action	204

	Page
Figure 6.26. Echo check-state variable statistics and state variable plot information	205
Figure 6.27. State variable values at time 0.0 month	207
Figure 6.28. State variable values at time 220 months	208
Figure 6.29. State variable plot for iteration 1	209
Figure 6.30. State variable statistics for iteration 1	212

ACKNOWLEDGMENTS

The author is indebted to his major professor, Dr. A. A. Husseiny for the guidance he provided throughout the investigation and preparation of the thesis. The author also wishes to acknowledge and thank King Abdul Aziz University for supporting this study, especially Dr. Abdullah Nassief, the Vice President of the University for his appreciable encouragement.

The author wishes to express his gratitude to his wife, Iman Khateeb for her help in preparing the manuscript.



## ABSTRACT

Factors affecting the transfer of nuclear technology from nuclear countries to Saudi Arabia are analyzed. The ideological, human, cultural, and economic factors are considered in detail. While the ideological and the economical factors provide a strong support to the nuclear technology transfer process, the human and cultural factors pose several difficulties. For example, present shortage in manpower is likely to cause delays in achieving any realistic objectives of establishing a nuclear energy program.

Public attitude toward nuclear energy has been assessed through a survey of various public sectors, and the results are analyzed and reported. The majority of the respondents support the development of a Saudi Arabian nuclear program.

A strategy believed to be viable for the transfer of nuclear technology to Saudi Arabia is proposed. This involves setting an objective of constructing three 1 TWe nuclear power plants in different regions of the country by the year 2000. The implementation program includes formation of a central committee devoted to overseeing the progress in nuclear technology transfer. Training programs, research and development institutions and enhancement of interest in nuclear energy are essential in achieving this goal. The proposed strategy

is tested via evaluation of variability in GNP and electric power consumption per capita.

The evolution of the transfer process is discussed and a deterministic utility technique is used to examine the viability of adopting, adapting or participating in construction of nuclear systems in the country.

A description of the available models used in the system analysis of the transfer processes is given with suggestion of new models for specific situations and phases of the transfer of nuclear technology. A system network model is developed to examine the monitoring of the development of transfer of nuclear energy programs.

## 1. INTRODUCTION

In spite of the declining interest in nuclear energy in the United States and some European countries, the recognition of the role of nuclear energy in development has attracted several developing countries to venture in this modern technology. The number of orders for nuclear plants by nonnuclear countries more than doubled in 1977 compared to the previous year (1).

The growing interest in nuclear technology has stimulated interest in the technology transfer process. Safety and quality of the operation of nuclear plants in non-nuclear countries is greatly dependent on the process by which the nuclear technology is transferred. The transfer process is rather unique due to the great degree of precision and the complexity of both the system and the procedure. In fact, many of the developing countries have hesitated in introducing nuclear energy in their industrial sector due to the tightness of safety regulations and the great demand for highly qualified and trained personnel. The high capital cost has also discouraged some of the underdeveloped economies. Worries about supply of fuel and spare parts have represented a major problem in the process of nuclear technology transfer (2).

The complexity of the transfer of nuclear technology has



resulted in great fear and pessimism in developed countries towards the acquisition of nuclear plants, whether for power production or desalination, by countries lacking the sufficient manpower or finance. Some investigators conducted a preliminary assessment of the use of nuclear energy in the Middle East and concluded in 1971 that such action is not economically feasible and is technically difficult (3). A 1973 case study of the development of Saudi Arabia recommended against the use of nuclear energy in generation of electricity due to the shortage in manpower (4). More recent studies have shown that dual-purpose nuclear power plants are necessary for economic growth and technical progress of Saudi Arabia (1, 5).

The Kingdom of Saudi Arabia is in a unique position compared to other developing countries due to a high gross national product (GNP) combined with abundance of energy resources and extreme shortage in manpower. The financial capabilities of the Kingdom have made it possible to initiate and carry out major development projects in the past decade through the importation of manpower, machinery and equipment (6). A simultaneous program has been started to build the national human resources (6). Such programs are unlikely to yield appreciable results in the near future.

Considering the important role of the transfer of

nuclear technology to developing countries and the potential role of nuclear energy in their development, this study was conducted to: (1) identify essential facets of the transfer process, (2) identify the major factors which may affect the process of transfer of nuclear technology to developing countries, and (3) define and recommend viable strategies to achieve the development goals. Saudi Arabia is used as a case study with a time frame covering the next two decades. Many of the factors studied apply to some extent to countries in the Arabian Peninsula, and to other countries at the same level of development having similar assets and debits.

In Chapter 2 an assessment is made of the factors affecting the transfer of technology in general and nuclear energy in particular. Ideological, cultural, human, and economic factors are presented in detail. The public attitude in Saudi Arabia towards nuclear energy has been assessed through a questionnaire and responses have been solicited from a random sample of Saudi citizens, and the results are analyzed and reported.

In Chapter 3 a strategy of action is developed based on the needs and characteristics of the country. The trend of evolution of the transfer process is also discussed. A deterministic utility methodology has been used to examine the viability of adopting, adapting or actively participating

in construction of nuclear systems. The relevance of the analysis to the nuclear technology transfer process is embedded in the choice of the attributes. The results are presented in Chapter 4.

Available models used in systems analysis of the transfer processes are described in Chapter 5. New models are suggested for the analysis of specific situations where available models fail to apply.

In Chapter 6 a system network model is developed to examine the monitoring of development of transfer of nuclear technology programs and the model is applied to a scenario to illustrate its applicability. Finally, conclusions are drawn and recommendations given in Chapter 7.

## 2. FACTORS IN TRANSFER OF TECHNOLOGY

There are several factors which affect the flow of technology from developed to developing countries. These include factors unique to the developing countries; such as ideological, social and cultural factors. The impact of the monetary and human capital on the transfer process is common to all technology transfer processes whether within a given country or between several countries. International politics may also slow or enhance the transfer process.

In this chapter detailed consideration is given to those factors which are unique to Saudi Arabia and which are expected to affect the transfer of technology in general and nuclear technology in particular. Other factors are discussed briefly and a comparison is made between the case of Saudi Arabia and the situations in other countries.

### 2.1. The Ideological Factor

#### 2.1.1. Present trends

Ideology plays a major role in the technology transfer process. Influenced by the rivalry between science and religion in western civilization, some philosophers and scientists dismiss the possible coexistence of traditional ideologies and technology and regard local beliefs as a



hurdle in the path of progress. New ideologies have been created to exist in harmony with the technological development. Many modern planners feel that material incentive is the main ingredient of technological development, that the conflict between development and traditional ideologies is likely to persist, and that the gap between material and spiritual endeavors can only be superficially bridged. Consequently, such planners hypothesize that transfer of technology to developing countries cannot flourish except in a secular environment.

#### 2.1.2. Hypotheses

Examination of the ideologies prevailing in Saudi

Arabia would provide a means to test the following hypothesis:

. . . success of transfer of technology processes from one system to another necessitates one of the following:

- (1) weakening of the local ideology to eliminate resistance to changes associated with technological progress,
- (2) replacement of the existing ideology with another based on reason and materialistic outlook so that pursuing technological development will be in accord with individual goals and hence motivation for progress will not be subject to psychological conflicts, and
- (3) tailoring of the transfer of technology process to be in harmony with the present ideological system of the recipient nation state.

### 2.1.3. Local ideology

The very existence of Saudi Arabia is credited to Islam which is the faith of all the local people. Islamic traditions have been in existence in the Arabian Peninsula for nearly fourteen centuries. Several Islamic teachings are pertinent to transfer of technology. Although faith is highly valued and respected by the majority of the public, the adherence to the teachings varies with time and place. Often ideological traditions are overshadowed by cultural behavior patterns. However, orthodox movements have a strong foothold in the country. Continuous and periodic efforts are spent to rejuvenate the faith of the public, to revive understanding of religious teachings and to henceforth bring about their implementation. Islam, unlike other ideologies, does not have ordained ministers to carry the banner for protecting its traditions or reminding the public of its teaching. Such duties are the responsibility of the community, the government and the planners.

### 2.1.4. Attitude towards work and labor

In the Islamic tradition high respect is given to those who work hard for a living, especially labor; such as technicians who do work by hand or do menial jobs. Those are considered as beloved followers. People who are physically capable of living their living by work or trade but prefer

to live on welfare are inferior to those who work and contribute to the welfare and charity of the others.

Working for personal and community welfare is regarded as signs of being pious and as an act of worship. However, unlike some contemporary ideologies work in itself is not a goal but rather a means of personal independence in acquiring sustenance and of serving others.

#### 2.1.5. Dedication

The fact that work is an act of worship and that the goal of work is to seek God's pleasure has made dedication a basic element in conducting any job. Carelessness and lack of devotion even in worldly affairs, if prevalent, is regarded as a sign of hypocrisy.

#### 2.1.6. Quality

The Islamic teachings make obligatory for those who start a task to finish it properly. Completion of work and assurance of quality in workmanship and product are considered distinct attributes of the believers. Attempts to deceive the buyer by phony schemes and rip-off tactics are equated with playing mockery on the Supreme Being.

#### 2.1.7. Conservation

Muslims have been urged to act wisely in utilization of natural resources. For example, waste in water consumption even on a river stream, has been advised against. Generally, moderation in consumption has been highly appraised.

#### 2.1.8. Safety

A Muslim is asked to be conscious of the welfare and safety of others in all his activities. Severe penalties are against those who by their actions, cause loss of life or harm others even unwittingly. Those who endanger the health or life of the public have been warned of God's punishment.

Occupational safety is of major concern in the Islamic law. Measures of industrial safety have been implicitly set in the tradition. Due compensation for accidents caused by acts of negligence or of undermining safety regulations are set by law.

#### 2.1.9. Environment and ecology protection

All animals of the biosphere are regarded in Islam as "people" like human beings or children of Adam (7). According to the Quran, God has "ordained in earth food equally for all seekers" (8). Consequently, man must recognize the rights of all creatures of God to environ-



mental resources. As an ethical command of the Islamic law man must avoid environmental disruption (1). This is also necessary to protect public interest and universal common good of all mankind as well as other "peoples" of God. Any kind of harm to the beings on earth resulting from man-made activities is regarded as infringing on the rights of others, subject to severe punishment by Islamic law.

#### 2.1.10. Productivity

The Muslim has a responsibility in the day of judgement to account for his/her time, how it is used and how it is spent. Time must not be wasted haphazardly but must be highly valued. This principle and the sense of dedication requires that Muslims must be productive in any undertaking. However, production must be useful and not be a goal in itself but rather a means to serve the community and the others. Also, high productivity must not undermine other Islamic principles, such as labor safety or quality. Furthermore, productivity is only a vehicle of utilization of one's best abilities and hence the elder or the handicapped must not be denied the opportunity to participate in work and earn a living. This is in spite of the fact that the Islamic state is responsible for providing food, clothing and shelter for every human under its rule.

#### 2.1.11. Competition

Competition is only encouraged if it is devoted to the pleasure of the Supreme Being whether in religious or worldly matters. Although Islam recognizes competition among individuals for the sake of superiority in materialistic affairs as a human trait, such competition is discouraged as an evil. Since all Muslims are devoted to one God, they are expected to cooperate to reach their goal while competing through efforts and investments.

#### 2.1.12. Stability

Civilization is regarded by a Muslim as incidental phenomenon and the history as an aggregate of events packed in a continuum which have no effect on the nontemporal principles of Islam. The permanent and immutable character of Islam is symbolized by the stability of the cube of the Kaaba (holy shrine) in Mecca, Saudi Arabia. Mecca is the heart of the Muslim civilization around which Islamic rituals are centered (9).

The train of thoughts of a typical Muslim are directed towards realization of Islamic principles with less interest in cultivating originality and change as intrinsic virtues. Hence, science and technology once transferred to a Muslim country are expected to acquire a state of stability and crystallization rather than being subject to change and

adaptation. To assume stability transferred technologies have to pass through stringent scrutiny.

Stability in the Islamic sense is too often mistaken in the Western industrialized societies today for stagnation and sterility (9). The modernists philosophy in present industrial societies considers mere change a virtue for its own sake. The faster the things change, the better. The basic difference in the outlook between Islam and the modernistic ideologies which prevail in industrial societies is attributed to the fact that Islam is based on nontemporal principles and the adoption of objective, absolute criteria for truth. In contrast, modern ideologies reject transcendental values and postulate that truth is only relative and its validity is limited to time, place and circumstances. Thus, the supreme virtue of modernism is for the technology to be "up-to-date", "new" or the "latest". The conflict between the foundation of the two philosophies leads to the sequence that societies based upon Divine revelation are dubbed by the modernists as "static" and "petrified" (10).

#### 2.1.13. Adoption and adaption

The Islamic ethos has set forth a triadic methodology for the continuous growth of Islamic civilization. First, Islamic law ordains invention and innovation through



systematic original thinking or independent reasoning. Second, assimilation of alien technology into the Islamic system may be done through selective imitation. However, blind imitation is strictly forbidden in all aspects of the Muslim activities. Third, assimilation may be achieved through review, reform and adaptation. The Islamic law has laid down the criteria for acceptable assimilation of alien culture, technology or science in the Islamic realm.

Innovation and imitation using the various mechanisms of diffusion and borrowing are only possible with respect to matters about which the Islamic law is neutral. Such matters should belong to the domain of what is permissible, but is neither obligatory nor forbidden.

#### 2.1.14. Basic differences between Islam and technological ideologies

A general criterion does exist to govern all activities of a Muslim society, namely, any action including transfer of technology should be done only if it does not harm others, and only if there are obvious individual, social, or global benefits which can be drawn from such action. This is based on the assumption that individual interest must not be in conflict with the interest of the others.

In contrast, contemporary technological ideologies are universal in nature and have a relatively greater

freedom; as empirical vehicles of industrial systems, from value-orientations which are unique to a value-system. No bounds are set to confine technological development as long as demand or salability of the produced goods exists and profit can be made at acceptable level. Productivity and salability of technological outputs are the major goals. Value-judgement may enter as public reaction; however, unless such reactions are translated into reduction of sales and profit, their effect can only be incidental.

Faith in science and technology in technological ideologies vis-à-vis Islam ideology are not mutually exclusive, since man is the ultimate controller and contributor to scientific progress. The faith in science and technology has been enriched in industrial societies by the appearance of strong nationalism. Without reliance on technological development national superiority and domination over competitive markets can be undermined. Islam does not accept the axiom of nationalism as a vehicle through which human welfare can be secured. Nationalism is envisioned as a collective worship of one's own group which is inherently combined with hatred of other people and minorities. Islam also rejects the hypothesis of the limitless power of science and technology since this is embedded with man-worship (10).

In many modern societies industrialization and

urbanization are used as social weapons to destroy the family structure and sever community relationships. People are valued by their productivity and hence a sense of contempt for the aged and the handicapped has developed all through the industrial revolution. It was only recently when a movement started toward an attempt to give a chance for the elderly and the handicapped to explore their usefulness. In comparison, Islam sets up the social and family structure as a basic foundation, Industrial development must be tailored to fit the Islam foundation rather than change the society to suit industrial progress. All human beings are equal and have the same rights regardless of their faith, color, race, creed, age, or physical condition. Every human has abilities and a value which can be of benefit to the community.

#### 2.1.15. Test of hypotheses

From the above discussion, it is obvious that the transfer of technology to Saudi Arabia can be encouraged only by recognizing the ideological factor. Undoubtedly, technology can excel in an environment wherein workers are dedicated and have inner drives to complete assignments, to provide high quality workmanship and product, to adhere to safety regulations and to practice moderation and conservation principles in all their activities, Social



respect for labor provides a healthy soil for industrial growth.

Resistance to change and rejection of harmful environmental and ecological industrial effects would slow the rate of technology transfer. The stability factor would require transfer of well-tested technologies and careful assessment of their viability. Similar precautionary measures are necessary to protect the environment and minimize ecological impacts of the transferred technologies. The transfer of technology process, within ideological constraints, can be devised to use the strength of the local ideology and be in harmony with it.

Consequently, the first and second alternatives of the hypothesis presented in Section 2.1.2 are rejected; the third alternative meets the requirements of the ideological test.

In fact, many developing and underdeveloped countries spend less effort, time and money on technology development than on attempts to replace local ideologies by industrial modernist philosophies, with the objective of providing a suitable environment for technology transfer. The consequences often are a rapid increase in individual materialistic demands beyond available resources; a social chaos, and regression in technological development.

## 2.2. Social and Cultural Factors in Saudi Arabia

In the assessment of technological development in a given country there is often a tendency to mix between ideology and local culture, assuming that a strong correlation exists between the two. In some situations, ideologies may be regarded as cultural phenomena. Social traditions may also evolve into ideologies. Since social patterns change rapidly with time and place the associated ideology must be continuously and regionally revised to avoid socio-ideological conflicts. This is not the case in Saudi Arabia due to the universal and nontemporal nature of Islam.

The religion provides broad guidelines and principles for social behavior. The methods of realization of those principles differ from place to place and may change with time. Occasional drift and deviation from the path identified by the guidelines does exist. Hence, revisions of social and cultural patterns have frequently occurred and have been encouraged by Islam. Consequently, one must combine the macroscopic analysis of the ideological factors that affect transfer of technology to a Muslim country with a microscopic analysis of the social and cultural factors. The later greatly varies with time and may differ from one place to the other in one country even when all the people



are of the same faith.

### 2.2.1. Life style

Population centers are greatly dispersed over a wide spread of land. A great number of the population leads a simple nomadic life. As nonsettlers, nomads are accustomed to a carefree life wherein they try to accommodate only for changes in weather and to cope with the hardship of a rugged nature. The help received by the government in terms of finance and health care has encouraged the development of scattered semi-settlements. The main contact with the rest of the country is only through trade. In spite of the recent vast development in transportation and communication, the majority of the public is living in relative exclusion.

The nomadic life style in a harsh hostile environment has created typical cultural patterns. Individuals are patient and are fond of nature without man-made modifications. Adherence to a systematic undertaking is not well-appreciated. A sense of resentment to rules and restrictions other than those imposed by religious or community obligations does exist. A resistant to urbanization associated with industrialization is likely to prevent enthusiasm for changes associated with transfer of technology.

The western region of Saudi Arabia being the center of the Islamic civilization, has attracted immigrants from all over the world for fourteen centuries. Thus, the population in this region is an integrated blend of Asians, Europeans and Africans who brought in a diverse of customs and traditions. The annual pilgrimage of Muslims (Hajj) brings a large number of people to the area who buy and sell various goods and products. Thus, trade is the dominant business in the region. Historically, the inhabitants of the Arabian Peninsula have been engaged in all forms of trade. Trade caravans used to be the principal ties between the north and the south. Practically, all the goods in the market are imported. The cities on the West Coast act as dispensing centers or warehouses for supply of internal and some foreign markets.

The increase in the GNP and per capita income from oil revenues has increased the trade activities and enhanced the chance for more participation in the market especially for small business and individual investments. Thus, the profit potential for individuals in trade much exceeds the return from industrial ventures or from taking part in technological conglomerates and enterprises. Small business and individual business ventures tend to assure mobility and personal freedom and hence are more compatible with the

nature of the people.

### 2.2.2. Social change

The social structure is greatly influenced by the immutable nature of Islamic principles. Thus, the majority of the public is conservative and is not likely to entertain basic changes in the family or community structure. Family ties and strong community feelings are sanctified. A fear of industrialization does exist among the people especially the move to urbanization and industrial expansion which has lead, in many societies, to breaking of large families into small fractions. In many countries, industrialization with the promise of high material standard of living has lured the able-bodied from the close-knit, well-integrated society of the rural village, the oasis or the small community to the anonymity of the big city (10). Families are broken and separated in the process and often the family ceases to exist as a self-sufficient economic unit. Woman emancipation is also regarded as one of the evils of modern industrialization. A differentiation between the roles of the sexes has been long treasured as part of the heritage of the people. Resentment to such changes would require a transfer of technology process that is able to preserve present social structure, otherwise local participation in the process will be unlikely and



great dependence on foreign manpower will become inevitable.

Anticipation of major social changes in the near future under the effect of industrial expansion is questionable. Past experience has demonstrated that deviation from the cultural patterns often triggers orthodox Islamic movements which are capable of eliminating the alien changes. The fact that the new developments in the country have not been able to accommodate indigent customs and social behavior has forced industry to look for outside help even in areas where locals can contribute more effectively. The gap is yet to be widened further since foreign manpower is imported from communities which have disintegrated under the pressure of urbanization and emancipation of women. Thus, resentment of technology as a weapon for family and community destruction is often associated with reluctance to accept foreigners who seem to fear the social changes caused by industrialization.

A rising nationalistic feeling has flourished in the past two decades in Saudi Arabia and is acting as a protective shield against alien cultures and foreign exploitation. Saudi Arabia has long treasured the Islamic tradition of universal brotherhood as opposed to nationalism. The change has been a result of the political troubles in the area, the spreading of anti-religion movements especially communist dogmas, the new wave of nationalism



which has overtaken the global political scene, the sudden increase in GNP and the rapid rise in the number of foreign workers in the country.

### 2.2.3. Effect of nonindigent cultures

Unlike most of the Middle Eastern countries, Saudi Arabia has never been colonized. Consequently, until recently there was no direct interaction with alien cultures. Presently, the ease of travel, the mass media and the presence of foreign nationals in the country have developed new channels for foreign cultures to infiltrate and to affect the local cultural and social patterns.

Earlier contacts and cultural interactions were mainly with other Muslims from different parts of the world. Immigrants and pilgrims have transferred many of their indigent cultures to Saudi Arabia. In fact, most of the cultural exchange activities in the Arabian Peninsula have taken place in the past by the seasonal trade caravans and by pilgrims. Probably the oldest and most regular channel of transfer of technology known to man is the Hajj, with the exception of wars and colonization.

#### 2.2.4. Attitude towards work

Consistent with the principles of Islam, work and productivity are not goals of life but means to achieve specific ends. Moderation is always recommended in seeking the ways to please God and a balance is often sought between social, family, ritual and work obligations as part of the act of worship. In practice, the balance could be tilted under social pressures until a corrective action is taken through the religious convictions. At the present time, such balance is not maintained and often social obligations tend to overtake persuasion and dedication to work. This is attributed to increased social pressures and to the oversystemization of work environment which is against the nature of the locals.

#### 2.2.5. Attitude towards technology

Technology is regarded as a temporal and accidental vehicle by which needs can be satisfied with a minimum effort and excessive expenditure. The general outlook to industry does not go beyond the expected potential services including the supply of goods to the market for trade. For the individual, the source of merchandise is of least importance as long as the price is agreeable to the customer and the profit is acceptable by the merchant. Technological advancement for long term planning and/or for improvement

of public services is the responsibility of the government, the decision-maker.

Technology transfer is likely to find a hostile environment in Saudi Arabia if it is forced on communities. A process must be sought to accommodate the local cultural, social and ideological factors rather than creating a confrontation between alien and indigent philosophies. Well-planned and careful transfer is likely to come to fruition faster than hasty and forceful introduction of modern technologies.

Manpower shortage is likely to require borrowing from the outside labor and skills market. To avoid potential conflicts between locals and foreign skills, technological centers may be established in excluded areas. However, no barrier should exist between the public and the workers; local or foreign, in those centers.

#### 2.2.6. Attitude towards labor

Most of the labor force in Saudi Arabia, especially those who do menial jobs, are from less fortunate countries or are opportunity seekers who feel inferior to the local community. The more skilled come from communities of entirely different perception of life and ideologies. Practically all labor is treated as migrant workers who come for short periods of time to do specific assignments.



The minority of the local labor force often consists of financially-troubled inhabitants of the Arabian Peninsula who are mostly migrant workers having no interest of belonging to the community.

The nature and the composition of the majority of the labor force has created a feeling of mistrust and concealed resentment among Saudi Arabian towards labor. A local would much prefer to work in an office than becoming a technician even for a higher salary. Traditionally, trade business has been the most appreciated profession. Currently government civil service is becoming more attractive since it provides some stability of income and fringe benefits while it still allows the individual to pursue a variety of business ventures. This practice is stimulated by the rise in GNP. Consequently, the gap between labor and the society is increasing in spite of the expansion in industrialization.

#### 2.2.7. Attitude towards nuclear energy

The attitude of the public in Saudi Arabia towards the introduction of nuclear energy in the industrial sector of the economy is that of resignation. Some feel indifferent to the possibility and only a minority of the educated elite are relatively enthusiastic but cautious. Such attitudes are attributed to several factors including:



availability of ample reserves of oil and natural gas to meet national needs for long time; reluctance to introduce an industry which may become totally dependent on foreign countries and fully controlled by the nuclear powers; worries of inability to acquire spare parts and possible interruption of fuel supply; and the common fear created by the earlier military uses of nuclear energy and the associated radiation hazard.

There is no doubt that Saudi Arabians are anxious to develop strong industries, to maximize the use of local human and material resources in improving the standard of living and in acquiring means of comfort, and to have self-determination in planning future development. However, some enthusiasts tend to underestimate the time element involved in the transfer of nuclear technology. Their attitude is that of aggressiveness and willingness to gamble (1). Other facets of the public attitude in Saudi Arabia include opposition to industries completely controlled by outsiders, concern about economic loss caused by international politics, and fear of establishing a new elite by expanding heavily in one technological sector requiring special training and high levels of sophistication (11).

A questionnaire has been developed to assess the attitude of a sample of Saudi Arabian towards the introduction

of nuclear energy into the country. The questionnaire is given in Appendix A. The sample includes students at different educational levels and others with various educational backgrounds. The total number of people surveyed is 313.

Table 2.1 shows the percentages of those who are in favor of, against, or indifferent to the introduction of nuclear technology to Saudi Arabia from among those interviewed. The degree of familiarity with nuclear energy is also indicated.

Table 2.1. Attitude towards nuclear technology as function of familiarity with nuclear energy

Degree of Familiarity	Attitude			
	In Favor (%)	Against (%)	Indifferent (%)	No Opinion (%)
High	55.32	26.60	12.77	5.53
Negligible	44.94	34.83	15.73	4.49
Total Number	161	87	50	15

It is clear that the percentage of acceptance of nuclear technology among the Saudi Arabians is rated high among those who are familiar with nuclear energy. The ratio of acceptances to rejections is about two. Only 5.5 percent declined to give any opinion, 12.77 percent feel indifferent towards introduction of nuclear energy to the country. On the other hand, the percentage of

the people who are not familiar with nuclear technology but yet are supportive is higher than those who are opposed from the same group. The ratio of acceptances to rejections among the people who are unfamiliar with nuclear energy is about 1.3. Only 4.49 percent have no opinion, and 15.73 percent feel indifferent.

Table 2.2 represents the educational status of the people who are against, in favor of or feel indifferent to introduction of nuclear technology in the country. Acceptance of nuclear energy utilization is at its highest level among high school students. The response is 58.06 percent in favor and 17.20 percent against, while for undergraduate university students is 53.42 percent in favor and 31.51 percent against. The ratio of acceptances to rejections among the students in high school is 3.4 and for undergraduates, 1.70. That is the number of high school students in favor of the introduction of nuclear energy to Saudi Arabia is 2 times the number of undergraduate supporters. Graduate students enthusiasm is less than both the high school or undergraduate students. Among university graduate students, 41.86 percent are in favor and 37.21 percent against. This means that the ratio of acceptance to rejections among graduate students is only 1.12. This ratio for other sectors of the public is 1.22.

Table 2.2. Educational level of people surveyed

Attitude	Educational Level				Total Number
	Graduate Students (%)	Under-Graduate Students (%)	High School Students (%)	Others (%)	
In favor	41.86	53.42	58.06	35.48	161
Against	37.21	31.51	17.20	29.03	87
Indifferent	18.60	13.01	18.28	18.35	50
No opinion	2.33	2.05	6.45	16.13	15
Total Number	43	146	93	31	313

From the ratios of acceptances to rejections, it is clear that the attitude of the people towards the introduction of the nuclear technology, to the country is practically favorable.

Several important points may be noted here. The enthusiasm towards nuclear energy among the young Saudis is more significant than among other age groups. This may be partially due to immature aggressiveness. However, the new generation is more inclined to expansion in technology than older more conservative generations. The higher educated are more reserved in their answers. The attitude of the Saudi people towards the nuclear is in general favorable.



Table 2.3 lists extreme responses which represent strong opponents or proponents and also those who are confused or disinterested about the subject. To know the

Table 2.3. Extreme responses

Strongly in favor (%)	37.06
Strongly against (%)	8.31
Confused (%)	3.51
No-opinion (%)	.64

motive behind the preference of the people, a cross is made between questions 9 and 28 and the result is given in Table 2.4. Preference of construction of one large nuclear

Table 2.4. Economic factor in the preference pattern

Response	Percentage
Yes, for economic reasons	62.30
No, for economic reasons	11.82

plant as opposed to several small plants is shown in Table 2.5. The technique of crossing questions 13 and 19 is used to obtain the results.

From Table 2.5, the number of people who are not familiar with nuclear reactors is 2.5 times those who are

Table 2.5. Preference pattern for construction of one large nuclear plant in Saudi Arabia

	In Favor (%)	Against (%)	Indifferent (%)	No Opinion (%)	Total Number
Familiar	65.38	1.92	11.54	21.15	52
Unfamiliar	63.85	5.38	6.15	24.62	130

familiar. This means that the mass media and the educational system in the country need to be activated to increase public awareness of technological matters. In both cases, the majority supports the construction of one large reactor to supply the electricity needs.

More information can be drawn from the answers of the questionnaire. The various answers are listed in Appendix A together with a computer program used to present and organize the answers. The program is based on SAS which is commonly used as an integrated system that can be employed in data management and statistical analysis since it is flexible in data manipulating and report writing (12),

### 2.3. Human Factors

#### 2.3.1. Quality control

The fact that the labor is formed from migrant-type workers seeking a hit-and-run type of opportunity have resulted in low quality workmanship. The credibility of

foreign engineers in industrial inspection and design is unlikely to be affected by their performance during the short time assignments in Saudi Arabia. Hence, in absence of strict local supervision they may overlook inferior design or construction practices which may yield more profit to their companies.

Furthermore, the absence of competitive markets or industries and the desire to expand have placed emphasis on quantity rather than quality of products. This has led to deterioration of workmanship and negligence of quality assurance. Also, the absence of heavy and precision industries and the lack of experience in large industrial projects have caused a deficiency in perceiving the value of maintenance and high operation standards (1).

### 2.3.2. Safety

The involvement of foreign personnel in operation, inspection and maintenance is likely to cause communication gaps and increase the potential of negligence and sabotage. Safety procedures can not be adequately implemented by delegation of responsibility to foreign nationals.

Furthermore, decisions dealing with regulations and standards of safety must involve the customer as well as the exporter, since field experience has shown that imposition of rules leads to chaos even under strict external

control (1). Nevertheless, local participation requires an ample source of manpower to provide well-trained personnel who have the interest to learn and work in technological development.

### 2.3.3. Training

There are no adequate training programs at the present time except of those offered by a small number of vocational schools for primary school students. The educational level of the students does not enable them to cope with any advanced industrial training program, such as that required for nuclear and chemical industries and other high precision industries.

There are several factors which have resulted in the nonexistence of adequate technical training programs and which may lead to obstructing the development of any future program unless viable solutions are found. First, there is an acute shortage of qualified instructors who are able to implement modern training programs and who are capable of communicating with the students. Most of the training techniques are not compatible with the educational level of students and are often not suitable for the job demand. The texts and manuals are frequently in languages unfamiliar to the students and the instructors may not be able to speak the local language.



Second, enrollment in technical and training institutes and vocational schools is very low and a sharp drop is expected in the near future. Training oriented schools are only capable of recruiting high school or university dropouts and elder students. The majority of the applicants have low grades. Others wish to graduate rather quickly because of personal financial problems. There is no financial or social incentive to join technical training programs. Local industries are not enough to absorb the graduates. This is in addition to the public attitude towards technicians and labor. Also, there is a strong competition between training institutes and universities to attract high caliber students. Academic institutions are likely to win because of having better qualified instructors, educational aids and laboratories, facilities and buildings. Usually, university graduates have a better chance after graduation to hold positions of high prestige in the society.

Third, military service is not obligatory in Saudi Arabia and hence the society can not capitalize on technical military training as is the case in other countries. In fact, the Saudi army technical training has helped in supplying skills to growing local industries.

Fourth, some foreign companies tend to escape the responsibility of training Saudis to hold specialist

technical jobs. This in spite of an existing law which requires that the percentage of Saudi workers in such companies should not be less than 60%. Those companies have been contracted for not less than 80% of the large important industrial projects in the country. Since practice on specialized industrial jobs is essential to the process of transferring technology, it can then be realized how much the training program is affected when the companies decline their role in building local manpower. However, it is understood that foreign companies; unless being pressured; will try to avoid the responsibility of training Saudis for technical jobs. This is because of fear of that they may no longer be needed in operating and maintaining the projects after construction if there were sufficient well-trained local workers and technicians to replace them. Furthermore, some foreign companies would be threatened if trained Saudis were to be in a position to supervise their work and check their adherence to the conditions of the contract. Usually, foreign employees in foreign companies do not cause such alarm to their company officials, even if they know that the contract has not been fully carried out. Also, training Saudi engineers and technicians takes both effort and time from the foreign company. Hence, it is more profitable to export low-paid trained workers to do the work using up less effort, time

and money.

#### 2.3.4. Research and development

There is no research and development (R&D) program per se in most of the technological fields, especially in nuclear technology. A long period of time is needed to establish adequate R&D programs. Currently, there is an insufficient number of specialists, well-trained engineers and qualified workers in the nuclear energy field.

Also, there are no laboratories and research facilities in the nuclear energy field. No graduate studies exist in Saudi universities in engineering and life sciences and particularly in the nuclear energy field. This has led to shortage in the number of qualified scientists to meet the needs of potential industrial and research centers. This problem is likely to result in: weakening of the role of universities in aiding the process of transfer of technology from developed countries and into continuous dependence of future nuclear industry in Saudi Arabia on experts from abroad. Also, universities will not be able to take part in supporting the development of scientific research in the country or to attract scientists and high caliber students.



#### 2.4. Economic Factors

The transfer of technology within a developed economy is basically done through profit motives and is usually aimed at development of a new line of product or improvement of available products to meet public or potential market demand. The continuous transfer of technology from concept to use is necessary to stimulate the economy through profit and acquisition of international markets. Advancement in technology is also the basis of political and military superiority.

Developing countries are interested in acquiring technology to improve the standard of living and to increase the GNP. Hence, the transfer of technology is aimed at maximizing the profit from the development. However, shortage in financial and possibly natural resources tends to hold technological progress at a standstill. In addition, profits from industrial expansion can not be easily obtained in a highly saturated market while the local technologies are in their embryonic stages.

The economic situation of Saudi Arabia differs greatly from other developing countries due to availability of financial and energy resources and low population. Also, there is no urgent need to expand the industry or increase the GNP. However, unlike developed countries, Saudi Arabian



financial resources are primarily tied to oil exports which are subject to fast depletion. Currently, all products and goods can be imported to satisfy the public needs lavishly without a strain on the economy of the country. Temporal standard of living can be maintained at high level for as long as oil is pumped from the wells on the East coast. Reasonable political power and security can be attained due to the present control of a strategic energy source.

The transfer of technology and in particular, nuclear technology is unlikely to yield immediate profit and hence the benefits can only be drawn in the long run. Hence, present financial investments in technology are part of future long term planning. Consequently, one can not expect enthusiasm in the public sector to invest in transfer of technology and all the burden is likely to be placed on the government (13). This is especially true since local industries are not big enough to get involved in planning for future markets or industrial ventures.

#### 2.5. Summary

The local ideology can inherently stimulate the process of technology transfer since the principles are in coherence with the requirements for building a strong technology. This is, providing that the transfer process does not involve transfer of alien ideologies but can be tailored to exist in

harmony with the immutable Islamic principles.

The social, cultural and human factors which are likely to hinder the progress of technology transfer are caused by deviation from the ideological principles. Rejuvenation of Islamic understanding would eliminate or alleviate the impact of the deterrent factors.

Availability of finance at the present time should be an encouragement for the planners to start a vigorous transfer of technology program before serious changes in the economy of the country to assure a healthy future economy. The ideology provides here an incentive to the public since the Islamic traditions pursue the Muslim to plan for future as if life were eternal.

### 3. STRATEGY FOR TRANSFER OF NUCLEAR TECHNOLOGY

#### 3.1. General Principles

A realistic approach based on technical analysis of the problem of transfer of nuclear technology involves the basic elements described below. Those apply in many aspects to both of the contributing and recipient countries. The payoff in the long run of following these guidelines would include avoidance of the setbacks suffered by early and recent programs (13).

##### 3.1.1. Framework

Attempts made to identify complications associated with the nuclear technology transfer process tend to overlook the real causes of failure of earlier programs. Most of the earlier studies are limited to exploring whether or not it is feasible; at this time, to establish media for global exploitation of nuclear energy. Others have concentrated on educational affairs or on blaming the status quo of economic, social, political, and human development (14, 15). Also, there is a tendency to base recommendations on prima facie information and purely presumptuous data (3). Thus far, no attempts were made to synthesize plausible modifications for present strategies of nuclear energy transfer. An ex post facto assessment of earlier projects in developing

countries is necessary to identify a novel approach to solve recognized and anticipated problems which are likely to develop in the transfer process taking into account mutual interests of both the contributing and the recipient countries. The Schumpeter theory of economic development (16) can be used as a framework for the interpretation of field observations. The theory defines two states: a dynamic state identified by a great flux of technology transfer and a circular flow state characteristic of the antique Oikenwirtschaft or household economy. Innovating entrepreneurs are the channels through which transition can be made from the static circular flow to the dynamic state.

### 3.1.2. Human capital

Human capital is a major element of the nuclear technology transfer strategies since the initial conditions are set up by careful assessment of local skills. Decision-making must be founded on accurate statistics of requirements and proportions of engineers, technicians, managers and maintenance and operation personnel. Specific skills must be provided via practical field work, actual participation in all phases of nuclear projects, involvement in tasks wherein quality assurance and high quality workmanship are emphasized and practice of the art of innovation even through imitation. Creation of innovating entrepreneurs is the



backbone of viable transfer processes. Underutilization of local manpower is likely to slow down the process and to deteriorate the competence of newly developed skills. Corrective policies are needed to exploit indigenous technologies even at the expense of high social cost in the short term. Issues such as inadequacy of available human capital, barriers between local and technological cultures and brain drain must be analyzed as technical problems rather than socioeconomical paradoxes. The transfer process is endangered by present emphasis on education in terms of increase in college degrees holders, of production of bureaucrats with life-guaranteed jobs and of establishing a hierarchy based on academic degrees. In contrast, a viable transfer of nuclear technology program requires emphasis on competence, innovation, and on systems of liability, penalty and reward (13).

### 3.1.3. Planning

Planning must be done with due patience for long periods without major disruptions using calculated feedback re-iterations. Stability and continuity are important elements of success. The decision-maker must employ systematic and scientific methodologies in designing and implementing strategies. This requires a high degree of technical sophistication. Limiting decision-making to political domains

infested by transients induces confusion and obstructs the flow of the transfer process (13).

#### 3.1.4. Communication

For a specific nuclear project in a given location, lingual barriers between persons in charge must be eliminated and means of communication must be improved. A program is required for translation, adaptation of foreign experts to working environment and mutual understanding between the management at different levels.

Adequate information flow must be made to support the transfer activities. Books, references and current literature need to be available and to be within the financial capability of local technical people. This may require subsidizing and printing of special nonexpensive editions of basic resources (13).

#### 3.1.5. Financial risk

Financial participation of recipients in the transfer projects is likely to enhance the chance of success on the expense of elongating the period of achieving specific national goals. Pools of nations or local private enterprises may be formed to share the economic risk involved since the magnitude of investment is usually beyond the capability of a single small country (13). The financial risk is not expected to be a major problem in the case of

Saudi Arabia. Nevertheless, private participation with the local government could represent a major commitment which would enhance the chances of success of nuclear technology plans in the country.

### 3.1.6. Evolution

A commonly accepted myth is the contention that technology can be transferred at any point in time and place providing proper finance is available. Consequently, planners in many developing countries operate under the false pretention that industrial expansion is only a matter of capital availability which if acquired technology superiority can be warranted. Consequently, no attempts are made in some underdeveloped economies to participate in the act of technology development since technology is perceived merely as a commodity which can be purchased at a price. The merging of resources-rich countries with dwindling indigenous technology in spite of extreme wealth has caused such illusions to fade away.

The history of mechanization and technology has revealed the fact that a useful advanced technology product passes through a process of evolution encompassing a long chain of innovations starting from a crude concept. The flow of innovation is the prime mover of the dynamic transfer of technology state. Through the evolution process



local skills are sharpened and trained. A similar process takes place in many developing countries at a different level. Technicians and specialized workers do inherit their skills from their forefathers. The technical skills are usually improved through trials of new approaches and through attempts to modify and simplify the older techniques.

True perception of the evolution nature of technology transfer does provide the planner with the right sense of timing for implementing decisions related to technology transfer. Hence, earlier planning to achieve long term goals is necessary. Prior to introducing modern sophisticated technologies in nonindustrialized countries a lead time must be allowed during which innovative and technical skills must be allowed to develop. This can be done through earlier participation in the development process and through involvement in simple technologies. The sophistication of modern technology and the complexity of the development process makes inheritance of skills practically an obsolete commodity. In developed countries technical skills are stimulated in children at an early age through learning to assemble simple kits of useful systems and miniature modeling.



### 3.1.7. System

A major requirement of successful transfer of sophisticated technologies which require quality and precision is the presence of a well-established system. The majority of the public are not accustomed to systematic undertakings wherein emotional, personal and political factors have little or no implications. The required system is characterized by a stable dynamic equilibrium. Changes in administration or personnel would not upset the integrity of the system. In a sense, a technological system is a mechanization of working procedures with human elements as components which can be repaired or replaced with little perturbation to the overall function. Promptness, precision and vitality are main features of a healthy system. Nevertheless, the technological systematic approach in executing engineering projects does not prevail in a bureaucratic organization centered around a single authority.

### 3.2. The Saudi Arabian Case

The main factors which may affect the transfer of nuclear technology from nuclear countries to Saudi Arabia are presented in Chapter 2. Some of the difficulties which may face the transfer process are qualitatively analyzed. Based on the results of the analysis, a stratagem may be

developed to synthesize the optimal process which can be used to achieve a given goal at an acceptable level of finance and time scale. As a scenario, an objective is hypothesized below taking into account future projections and the present mode of the country. A strategy is then described to realize the objective within the assumed time limits.

### 3.3. Objective

As a scenario, a projection is made that during the next two decades the Saudi Arabian government would commission at least three 1000 MWe nuclear power plants in the Central, Eastern and Western regions. By the time the reactors are brought to full power the country is assumed to have ongoing training and support R&D programs and to have a supply of local skills. The nuclear power would be built to meet the needs of the public and the expected industrial activities in the area. Nuclear energy will be also used in sea water desalination. Other nuclear and radioisotope applications are expected to play a major role in various fields; such as agriculture and medicine. Furthermore, the transfer of nuclear technology would encourage and enrich scientific research through practical training and providing suitable research facilities. This would allow for developing the country from within by

gradual decrease in the import of manpower, training programs and the accompanying alien philosophies.

The transfer of nuclear technology is assumed to proceed systematically gradually at a steady rate within the specified time. This is to allow for development of universities and the industrial sector throughout the country. Furthermore, gradual technology transfer would alleviate the social problems associated with sudden transition to industrialization such as spread of crime and break down of close family ties.

#### 3.4. Proposed Plan Layout

The success of the proposed strategy strongly depends on the attitude of the Saudi officials towards the importance of the project. Their deep conviction and persuasion will give the strategy both the momentum and acceleration needed to implement the project within the time limit thus fulfilling the different objectives and extending to the other dimensions intended from the process of transfer of nuclear technology. Enthusiasm of the decision-makers may help in developing support industries for the nuclear program; in providing self-sufficiency in operating various local R&D programs, and in planning other new projects by local efforts.

The strategy calls for a close watch over both time



schedule and accuracy throughout the implementation phase of the plans. Because the different stages in the transfer plan are interchangeable and interdependent, delay in one phase will lead to further delay in the successive stages or to deviation from the suggested plan.

#### 3.4.1. Central transfer of nuclear technology committee

An independent central committee may be established for planning and supervision of the process of transfer of nuclear technology. The tasks of the committee would include development of a fully detailed technical and financial plan and setting up the schedule for implementation of the various projects. This committee would consist of a selected group of specialists in the nuclear field, construction, production, business administration and economics. The members should be Saudi citizens with experience in research and development and have the ability in decision-making. The committee should work in direct contact with the Prime Minister, and should have sufficient authority and financial power to execute their decisions.

A program of public information may be used as a channel of communication with the citizens. Contacts may also be established with other local establishments. The committee should provide the necessary recommendations to the national universities and institutions to coordinate the



efforts of nuclear technology.

Abdul-Fattah (6) suggested an agency within the government to carry the tasks of the committee proposed here. The agency would overlook the process of the development of power and water and provide all the necessary information pertinent to nuclear energy transfer.

#### 3.4.2. Training programs

Training programs should be developed to provide the special skills needed in nuclear facilities and atomic research centers and laboratories. Local personnel may be trained on operation, inspection, maintenance, management, administration and plant security. Special programs may be imitated to prepare new qualified instructors for the continuation of the training programs.

A training institute may be founded in one of the least industrialized small villages to gain public trust in technology. The institute should have enough facilities and staff to furnish adequate training services for not less than 50 persons per six months. The institute should have a training reactor facility of a capacity in the range of 50-100 kW thermal for practical training on operation, measurements, maintenance, inspection, repairs, refueling, monitoring, remote handling and occupational safety procedures. Short refresher courses may be offered

as needed by the atomic industry in Saudi Arabia. Periodical pamphlets may be planned to sharpen the skills and re-training and update the knowledge of the workers.

Special missions may be sent to nuclear countries for short periods to learn and practice recent methods of training and possibly participate in ongoing training programs to develop the skills to independently carry training programs in Saudi Arabia. The members of the mission must have the appropriate orientation and background to benefit from short term modern training abroad and to select from available modern programs the most appropriate ones for their country. They should also get acquainted with the most developed training techniques, equipments and simulators and instructional audiovisual aids. Channels of communication and continuous cooperation should be made available with well-known training institutes in nuclear countries and other developing countries.

A group of high caliber students may be sent abroad; under the supervision of one of the Saudi professors for planned training sessions in the companies likely to participate in the construction of research and power reactors in Saudi Arabia. Engineers and technicians may participate in similar programs to get acquainted with the nuclear systems to be used in their country. After ordering the nuclear plants, trainees may participate to some extent in

design, construction, selection of equipment, etc. Organized training tours may be arranged for the trainees to visit other reactor facilities to get acquainted with various work procedures and to have a complete picture of different methods of operation and maintenance. The supervision would be responsible for coordination, management and certification of the trainees.

#### 3.4.3. Research and development establishment

It is suggested that one central establishment for nuclear R&D should be set up in one of the small villages. A relatively large capacity; say 100 MW thermal nuclear reactor may be used for experiments. The center should recruit and select a group of highly qualified specialists in nuclear technology. The support R&D program would enrich the atomic activities in the country through research and experiments. The center would seek solutions to the generic problems that may develop throughout the execution of the nuclear projects. The R&D team should strive to modify the design and develop future reactors which could be more appropriate for the environment of Saudi Arabia. The establishment should also strive to develop the capability to design and construct nuclear reactors in Saudi Arabia at the end of the plan. Other nuclear activities should be developed simultaneously.



#### 3.4.4. Information centers

Establishment of information centers is one of the important requirements in initiating any technology transfer project. It becomes even more important in the case of developing an atomic industry because nuclear science and engineering encompasses a diverse of disciplines and the field is quite new. The centers could have a great contribution in facilitating the process of transfer of technology from developed to developing countries.

Briefly, the role of the centers would be to collect all possible information and data related to the nuclear field from different parts of the world in all languages and by all possible means. It is also their duty to compile data and information in a form which can be easily retrieved by scientists, engineers, researchers or laymen according to their needs.

For these centers to successfully fulfill their role, it is necessary to employ a team of specialists in the nuclear field, in data processing and handling and in information systems. Their duty is to keep track of pertinent scientific activities or technological development in any part of the world. It is also important to have a good communication network with international technical and scientific magazines and professional societies, to have representatives in each of the Saudi embassies abroad, and to establish



good national-international contacts. The centers may publicize news about scientific conferences, meetings or training sessions and encourage or sponsor local participation.

Adequate finance is necessary for the information centers to play a successful role in the transfer of nuclear technology. In fact, the centers could get engaged in a myriad of activities which can benefit the scientific and technological developments of the country and could reach to the public as well as help the decision-makers. Among the most important activities of these centers are:

- a) acquisition and distribution of media resources, maps, microfishes, microfilms and documentaries;
- b) acquisition of reference books, professional journals and scientific magazines, proceedings of symposia and conferences, and industrial and institutional reports;
- c) participation in international scientific and professional conferences;
- d) translation to the indigent language of literature in all subjects of special importance to the country or to the nuclear technology as a basic part of the information dissemination program; and
- e) publication of scientific and technical books of general use to both the universities and higher

education institutes and simplified pamphlets and booklets for the laymen.

#### 3.4.5. Higher education

The universities and high education institutes can play an indispensable role in supporting the nuclear technology program through research and education. Higher education in various technical fields can provide the needed specialists and services through encouragement of research and development of laboratories. Such contributions can be made by at least three Saudi universities which are located in the central, eastern and western regions; namely Riyadh University, University of Petroleum and Minerals and King Abdulaziz University. Each university may possess a small teaching reactor of a capacity not more than 50 kW, thermal.

Close cooperation should be established between those universities and the centers of research, information and training to coordinate their efforts and prevent duplication processes of work that could happen as a result of weak means of communication between these establishments.

It is very important that universities in Saudi Arabia make use of available international faculty and scientific exchange programs. This will strengthen local educational systems and provide a convenient channel for transfer of

nuclear technology. Local universities may make use of exchange programs in developing progressive curricula and in maintaining high standard academic excellence compared to other universities.

Furthermore, sending graduate students to foreign universities plays an important role in the process of the transfer of nuclear technology, though it is better to direct the students to fields of specialization that have practical importance for technology in Saudi Arabia. Often persons educated abroad get trained on research relevant only to developed countries and hence they end up as misfits to their countries as they return home. It is also useful to invite distinguished scholars, scientists and engineers to lecture or teach in Saudi Arabia for a period of time in fields which are locally needed in the country.

#### 3.4.6. International activities

Hosting international technical conferences and meetings serves different purposes including enhancement of local technological expansion, enrichment of scientific research and stimulating the transferring of nuclear technology process. International professional meetings would strengthen cooperation between Saudi scientists and other workers in the nuclear field. Frequent organized visits of scientists from foreign countries would establish a forum



for exchange of ideas related to specific local problems. Although international conferences usually deal with timely subjects of universal importance it may be possible to hold topical meetings to deal with subjects of special interest to potential nuclear industries in Saudi Arabia. Initiating such conferences in the country provides a good change to Saudi youths to help in organizing the meetings and gain experience in administration, organization and planning. In developing countries, there is a lack of this kind of experience which is commonly present in developed countries.

### 3.5. Evaluation of Objective and Strategy

#### 3.5.1. Achievement probability

The objective stated in Section 3.3 is to transfer nuclear technology at a rate and a way such that it becomes viable to build at least three nuclear power stations by the year 2000. Such objectives may not be totally or partially achieved due to external pressures, internal resistance or flaws in the design of the strategy or the execution procedure. Failure to achieve the objective may result; for example, from unexpected increase in restraints imposed by nuclear countries on transfer of nuclear technology or on export of nuclear equipment to developing countries. Other reasons for failure may result from change



in national priorities or from unexpected variation in public acceptance. Consequently, there is a nonzero probability that the strategy to meet the stated objective would only end in partial achievement of or failure to reach such an objective.

The overall objective may be partitioned into three events  $E_i$ , with  $i = 1, 2$  and  $3$  to represent successful achievement of the  $i$ th objective. The outcome  $e_i$  of event  $E_i$  may be considered as completion of the  $i$ th power plant within the allotted time  $t_i$ , for example, 20 years from start of the project. The probabilities  $p(e_i) = p_i$  represent the likelihood of outcome  $e_i$ , while  $q_i = p(\bar{e}_i) = 1 - p_i$  represents the probability that the outcome not  $e_i$  (or  $\bar{e}_i$ ) will occur. To calculate the probability of success of the strategy, the truth table given in Table 3.1 may be constructed. Assume that  $p_1 = p_2 = p_3 = p = 0.6$  and consequently  $q_1 = q_2 = q_3 = q = 0.4$ . The events are independent, that is the outcome of any event does not affect the outcome of the others. Also, the events listed in Table 3.1 are mutually exclusive and hence

$$P_{0/3} = q^3 = 0.064 \quad (3.1)$$

$$P_{1/3} = 3pq^2 = 0.288 \quad (3.2)$$

$$P_{2/3} = 3p^2q = 0.432, \quad (3.3)$$

and

$$P_{3/3} = p^3 = 0.216 \quad (3.4)$$

Table 3.1. Truth table and probability of partial or total achievement of the objective to build 3 nuclear power stations by the year 2000 in Saudi Arabia

Event	Probability	Outcome expected, number of reactors
$E_1 \ E_2 \ E_3$	$p^3$	3
$E_1 \ E_2 \ \bar{E}_3$	$p^2q$	2
$E_1 \ \bar{E}_2 \ E_3$	$p^2q$	2
$\bar{E}_1 \ E_2 \ E_2$	$p^2q$	2
$E_1 \ \bar{E}_2 \ \bar{E}_3$	$pq^2$	1
$\bar{E}_1 \ \bar{E}_2 \ E_2$	$pq^2$	1
$\bar{E}_1 \ E_2 \ \bar{E}_3$	$pq^2$	1
$\bar{E}_1 \ \bar{E}_2 \ \bar{E}_3$	$q^3$	0

where  $P_{j/3}$ ,  $j = 0, 1, 2$  or  $3$  is the probability to succeed in completing the construction of  $j$  plants by the year 2000 provided the initial strategy was to build 3 plants at that time. Also, if  $P_s$  is defined as the probability of achieving the goal either partially or totally, then

$$P_s = 1 - P_{0/3} = 0.936, \quad (3.5)$$

which is reasonably acceptable under the given assumptions for this type of undertaking.

### 3.5.2. Impact of power production on living standards

The value of power production is better recognized in the frame of national wealth. Table 3.2 lists the GNP, annual income per capita, the electric energy consumption per capita for a sample of industrialized, developing, underdeveloped and oil countries. Information included in Table 3.2 are collected from reference (17). In the case of Saudi Arabia, the per capita income is \$7,400 in 1976 which is relatively very high considering the level of industrial development while the per capita electric energy consumption is as low as 719 kWh. About 99% of the \$44 billion GNP in 1976 is gained through oil export.

A relationship does exist between per capita income and per capita electric energy consumption if oil-rich countries are excluded. The functional relationship is illustrated in Figure 3.1. Increase in energy consumption is an index of increase in industrial activities which results in increase of GNP. The oil-exporting countries have a temporary rise in per capita income which is not correlated to level of development. Depletion of such natural wealth in resource would result in decline in GNP

Table 3.2. Average annual income and electric energy consumption in selected countries (1976)

Country	GNP \$10 <sup>9</sup>	Annual per capita income (\$)	Annual per capita consumption kWh
Canada	181.9	7,802	12,456
Egypt	11.2	300	236
France	353	6,650	3,903
Federal Republic of Germany	473	7,680	5,708
German Democratic Republic	63	3,750	5,290
India	73	117	148
Iran <sup>a</sup>	66	1,900	589
Iraq <sup>a</sup>	16	1,390	395
Kuwait <sup>a</sup>	13.9	13,500	4,233
Libya <sup>a</sup>	14	5,279	753
Niger	.454	100	11
Poland	87.6	2,550	3,030
Qatar <sup>a</sup>	1.8	9,700	3,979
Romania	50	2,330	2,715
Saudi Arabia <sup>a</sup>	44	7,400	719
Sweden	74.2	9,009	9,970
United Kingdom	215	3,837	5,874
U.S.A.	1,516	7,100	9,456
U.S.S.R.	897.3	3,400	4,317
Venezuela <sup>a</sup>	30.0	2,380	1,617
Yugoslavia	4.23	1,963	2,020
Zambia	2.10	412	1,262

<sup>a</sup>Oil exporting countries.



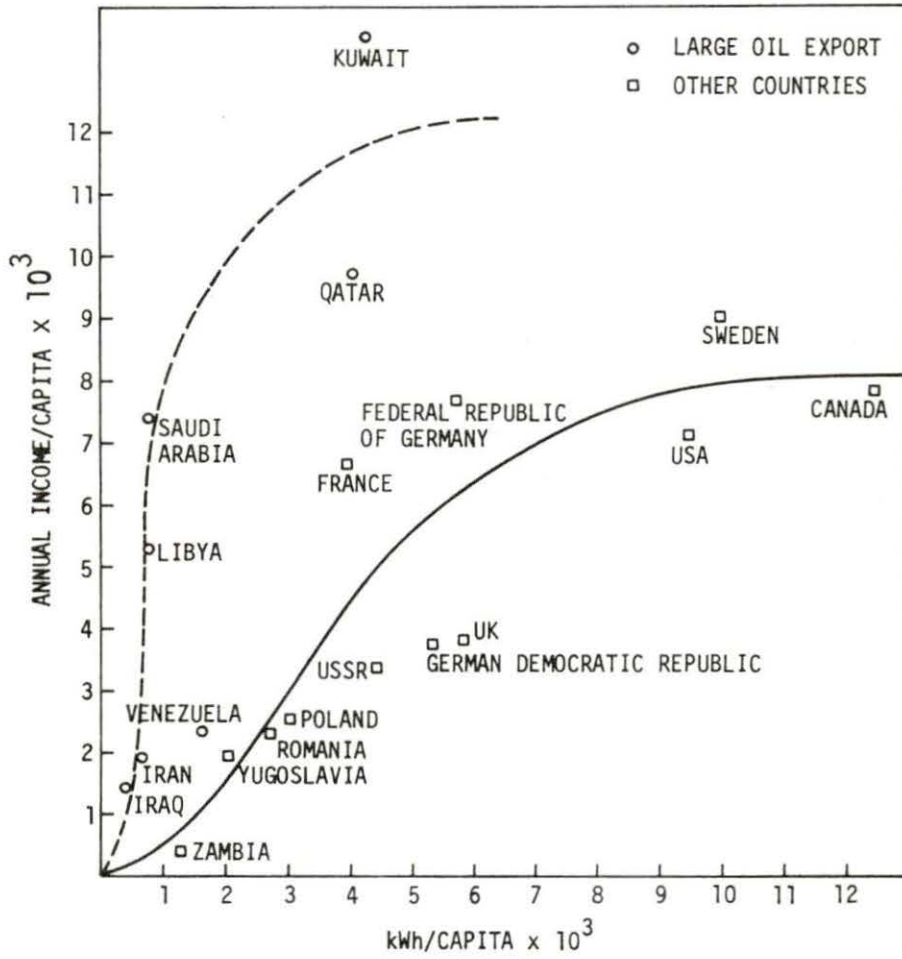

Figure 3.1. Dependence of GNP on power consumption

to the level of other developing countries. For example, the actual per capita income based on Figure 3.1 may not exceed \$500 per year in absence of oil export activities.

### 3.5.3. Measure of effectiveness

Since the GNP and power production are interrelated, change in GNP may be used as a measure of effectiveness of the transfer of nuclear technology. The functional dependence of annual per capita income  $S_I$  on the annual per capita electric energy consumption  $C_E$  is generally given by

$$S_I \equiv S_I(C_E, S_O) \quad (3.6)$$

where  $S_O$  represents income contributed to natural resources export, such as oil.

The change in  $S_I$  attributed to power production patterns can be represented in terms of utiles which are the units of the utility of a given attribute. The utility of  $S_I$  has a functional dependence that may be fitted by the form

$$u = A + Be^{CS_I} \quad (3.7)$$

where  $A$ ,  $B$  and  $C$  are parametric constants which vary according to the relative importance of  $S_I$ .

Use of utility to valuate decision and strategies

is preferred to the direct use of parameters such as  $S_I$  or GNP since the utility reflects the national or personal relative valuing of money, for instance. Figure 3.2 shows the utility function of annual per capita income for Saudi Arabia. Such curve may take a different shape for other countries, individuals or groups of people. The shape depends on cultural, social or ideological valuing of money. It is also sensitive to public assets and ambitions.

In the present stage of development in Saudi Arabia it will be a difficult task to synthesize a utility function which depicts the value of per capita kWh as a representative measure of appreciation or indifference to decrease or increase of power production.

#### 3.5.4. Test of alternate strategies

Consider the objective stated in Section 3.3 and assume that there are three other alternate objectives for the transfer of technology. The alternate strategies are listed in Table 3.3. The impact of each strategy on the GNP will depend on whether or not oil export has declined by the year 2000. One could estimate a probability  $p_0 = 0.9$  that present oil export level will be maintained in this period of time and hence  $q_0 = 1 - p_0 = 0.1$  is the probability that the oil export will decline to the extent that income from oil will result in a nonsignificant contribution to GNP; that

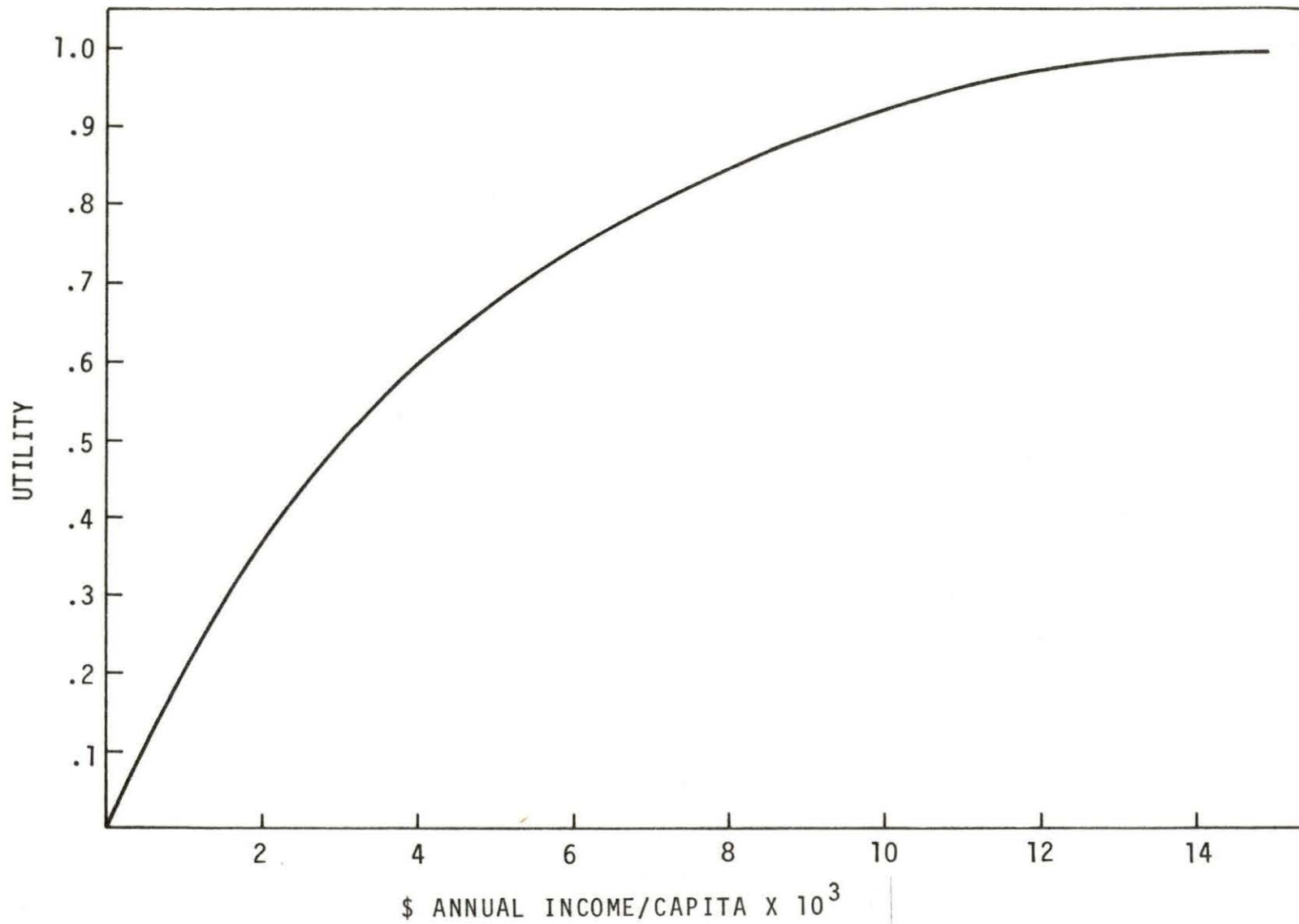

Figure 3,2, Utility function of annual per capita income for Saudi Arabia



Table 3.3. Alternate strategies for transfer of nuclear technology

Number	Strategy for year 2000	Additional power $MW_e$	Number of plants	Annual per capita consumption $C_E$ , kWh
I	Maintain status quo	0	0	719
II	Add single plant	1000	1	1,323
III	Add two plants	2000	2	1,927
IV	Add three plants	3000	3	2,531

is  $S_0 \approx 0$  in Equation (3.6).

Equations (3.6) and (3.7) or both the curves shown in Figures 3.1 and 3.2, can be used to evaluate the alternate strategies listed in Table 3.3. A decision tree is displayed in Figure 3.3 to show the alternate strategies and all possible outcomes. Table 3.4 provides a list of decisions involved at each decision point. The probabilities used in calculating the likelihood of each outcome are given in Table 3.5. The outcomes labelled on the decision tree are listed in Table 3.6 giving the corresponding definitions, probabilities and utilities. Success of fossil power plant construction is assumed to have 100% probability and failure in construction of a nuclear power plant will be accompanied by replacement with a fossil plant of equal

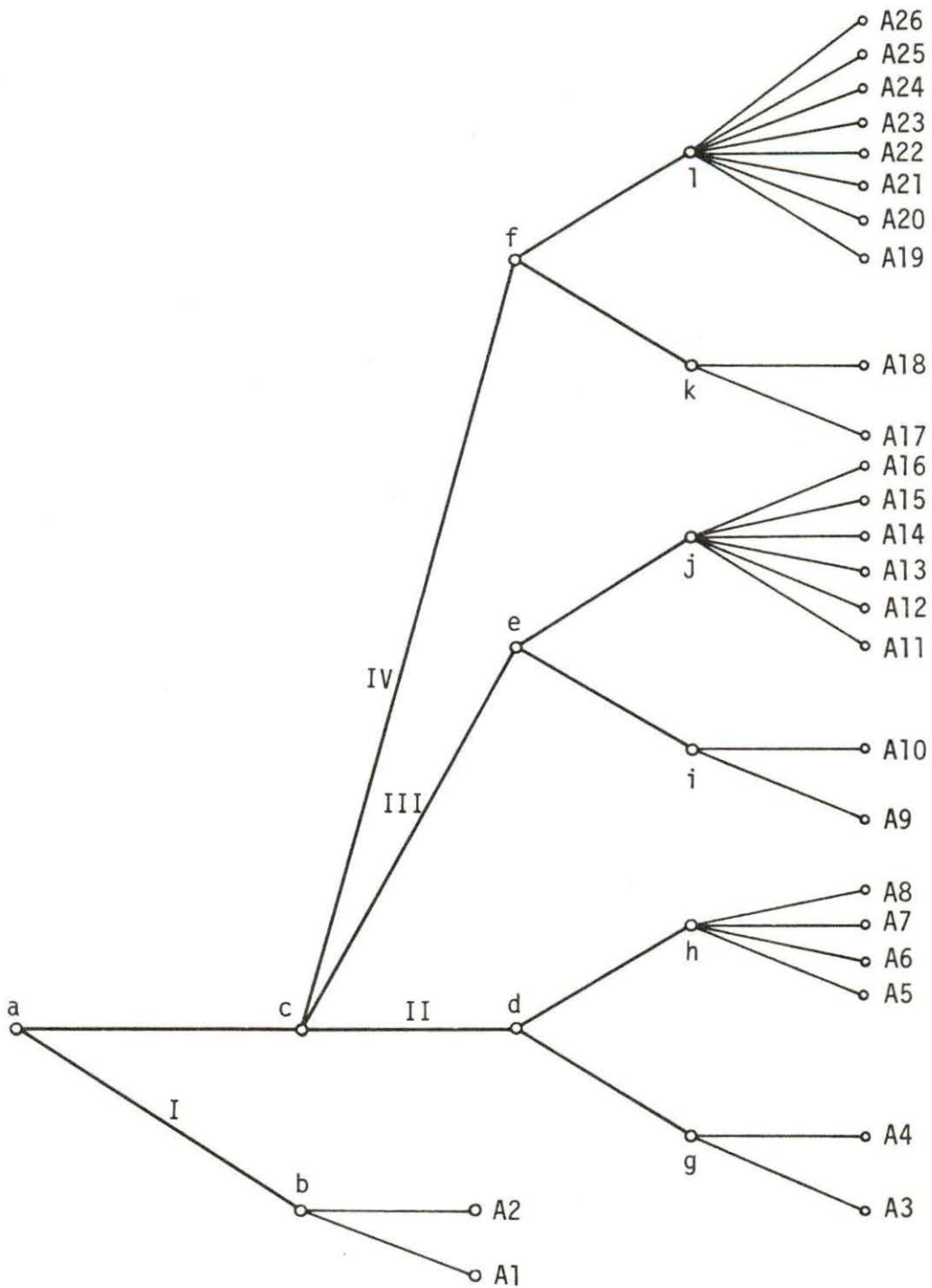

Figure 3.3. Decision tree for choice of alternate strategies of transfer of nuclear technology to Saudi Arabia, target date 2000

Table 3.4. Decision points of Figure 3.3 for alternate strategies for transfer of nuclear technology to Saudi Arabia; target date 2000

Decision point	Decisions (outcome label)
a	<ol style="list-style-type: none"> <li>1. Add more power</li> <li>2. Maintain present consumption rate per capita</li> </ol>
b	<p>Given status quo (719 kWh/capita-year) (alternate I)</p> <ol style="list-style-type: none"> <li>1. Oil export maintained (A2)</li> <li>2. Oil export declined (A1)</li> </ol>
c	<p>Given, more power to be added</p> <ol style="list-style-type: none"> <li>1. 1000 MW<sub>e</sub></li> <li>2. 2000 MW<sub>e</sub></li> <li>3. 3000 MW<sub>e</sub></li> </ol>
d	<p>Given, a goal of 1,323 kWh/capita-year (alternate II)</p> <ol style="list-style-type: none"> <li>1. Nuclear plants</li> <li>2. Fossil plants</li> </ol>
e	<p>Given, a goal of 1,929 kWh/capita-year (alternate III)</p> <ol style="list-style-type: none"> <li>1. Nuclear plants</li> <li>2. Fossil plants</li> </ol>
f	<p>Given, a goal of 2,531 kWh/capita-year (alternate IV)</p> <ol style="list-style-type: none"> <li>1. Nuclear plants</li> <li>2. Fossil plants</li> </ol>
g	<p>Given alternate II, fossil route</p> <ol style="list-style-type: none"> <li>1. Oil export maintained (A4)</li> <li>2. Oil export declined (A3)</li> </ol>
h	<p>Given alternate II, nuclear route</p> <ol style="list-style-type: none"> <li>1. Success and oil export maintained (A8)</li> <li>2. Success and oil export declined (A7)</li> <li>3. Failure, fossil replaces nuclear and oil export maintained (A6)</li> <li>4. Failure, fossil replaces nuclear and oil export declined (A5)</li> </ol>

Table 3.4 (Continued)

Decision point	Decisions (outcome label)
i	Given alternate III, fossil route 1. Oil export maintained (A10) 2. Oil export declined (A9)
j	Given alternate III, nuclear route 1. Success 2 plants, oil export maintained (A16) 2. Success 2 plants, oil export declined (A15) 3. Partial success 1 plant nuclear, 1 plant fossil replacement, oil export maintained (A14) 4. Partial success 1 plant nuclear, 1 plant fossil replacement, oil export declined (A13) 5. Failure, fossil replacement, oil export maintained (A12) 6. Failure, fossil replacement, oil export declined (A11)
k	Given alternate IV, fossil route 1. Oil export maintained (A18) 2. Oil export declined (A17)
l	Given alternate IV, nuclear route 1. Success 3 plants, oil export maintained (A26) 2. Success 3 plants, oil export declined (A25) 3. Partial success, 2 plants nuclear, 1 fossil plant replacement, oil export maintained (A24) 4. Partial success, 2 plants nuclear, 1 fossil plant replacement, oil export declined (A23) 5. Partial success, 1 plant nuclear, 2 fossil plants replacement, oil export maintained (A22) 6. Partial success, 1 plant nuclear, 2 fossil plants replacement, oil export declined (A21) 7. Failure, 3 fossil plants replacement, oil export maintained (A20) 8. Failure, 3 fossil plants replacement, oil export declined (A19)



Table 3.5. Basic probabilities used in computation of outcomes of each alternate strategy (Figure 3.3) for power production in Saudi Arabia, target date 2000

Probability		Value
p	Success to construct a single nuclear plant	0.6
q	Failure to construct a single nuclear plant	0.4
$P_{j/k}$	Success to construct j nuclear plants out of k planned (j/k)	
$P_{0/3}$	0/3	0.064
$P_{1/3}$	1/3	0.288
$P_{2/3}$	2/3	0.432
$P_{3/3}$	3/3	0.216
$P_{0/2}$	0/2	0.16
$P_{1/2}$	1/2	0.48
$P_{2/2}$	2/2	0.36
$p_o$	Present oil export maintained	0.9
$q_o$	Oil export declined	0.1
$p_f$	Success to construct fossil plants	1

Table 3.6. Outcomes of alternate strategies for nuclear technology transfer to Saudi Arabia, target year 2000 (Figure 3.3)

Outcome label	Probability		Annual per capita income, $S_I$ , \$	Utility, $u$ (utils)
	Expression	Value		
A <sub>1</sub>	$q_0$	0.1	400	.085
A <sub>2</sub>	$p_0$	0.9	7,400	.82
A <sub>3</sub>	$p_f q_0$	0.1	800	.16
A <sub>4</sub>	$p_f p_0$	0.9	8,700	.875
A <sub>5</sub>	$q p_f q_0$	0.04	646	.22
A <sub>6</sub>	$q p_f p_0$	0.36	8,546	.87
A <sub>7</sub>	$p q_0$	0.06	800	.16
A <sub>8</sub>	$p p_0$	0.54	9,100	.89
A <sub>9</sub>	$p_f^2 q_0$	0.1	1,400	.27
A <sub>10</sub>	$p_f^2 p_0$	0.9	9,750	.91
A <sub>11</sub>	$p_0/2 p_f^2 q_0$	0.016	1,369	0.256
A <sub>12</sub>	$p_0/2 p_f^2 p_0$	0.144	9,442	.90
A <sub>13</sub>	$p_{1/2} p_f q_0$	0.048	1,246	.24
A <sub>14</sub>	$p_{1/2} p_f p_0$	0.432	7,596	.905
A <sub>15</sub>	$p_{2/2} q_0$	0.036	1,400	.27
A <sub>16</sub>	$p_{2/2} p_0$	0.324	10,350	0.932
A <sub>17</sub>	$p_f^3 q_0$	0.1	2,305	.41
A <sub>18</sub>	$p_f^3 p_0$	0.9	10,500	.935
A <sub>19</sub>	$p_0/3 p_f^3 q_0$	0.0064	1,838	.34

Table 3.6 (Continued)

Outcome label	Probability		Annual per capita income $S_I$ , \$	Utility, $u$ (utils)
	Expression	Value		
A <sub>20</sub>	$P_{0/3}P_f^3P_0$	0.0576	10,038	.92
A <sub>21</sub>	$P_{1/3}P_f^2q_0$	0.0228	1,992	.36
A <sub>22</sub>	$P_{1/3}P_f^2P_0$	0.2592	10,192	.925
A <sub>23</sub>	$P_{2/3}P_fP_0$	0.0432	2,146	.38
A <sub>24</sub>	$P_{2/3}P_fP_0$	0.3888	10,346	.93
A <sub>25</sub>	$P_{3/3}q_0$	0.0216	2,300	.41
A <sub>26</sub>	$P_{3/3}P_0$	0.1944	11,400	0.956

capacity; however, a virtual loss of investment may accrue. The loss is not significant due to the other benefits drawn from the process of nuclear technology transfer.

Figure 3.1 is used to find the GNP corresponding to a given kWh per capita in case of large oil export and then oil exports are declining. Figure 3.2 is used to calculate the utilities for each strategy, which are listed in Table 3.6. Failure to construct a nuclear plant in time and the construction of a fossil plant replacement, will affect the GNP by the value of initial cost of the nuclear plant. Construction of nuclear plants will increase the GNP because of the associated saving of the oil that could

have been burnt as fuel in fossil plants.

From Table 3.5 the overall probability of all outcomes of any of the alternate strategies adds to unity. Table 3.7 lists for each alternative the utility which is given by:

$$u_n = \sum_{A_i \in n} p(A_i)u(A_i), \quad n = I, II, III, IV \quad (3.8)$$

where  $A_i$  represents the  $i$ th outcome in alternate  $n$ . Also given in the tables is the equivalent monetary value (EMV) defined as

$$S_n = \sum_{A_i \in n} p(A_i)S(A_i), \quad n = I, II, III, IV \quad (3.9)$$

where  $S$  is the annual per capita income.

Table 3.7. The outcome of each alternate strategy for nuclear technology transfer to Saudi Arabia, target date 2000

Alternate	EMV	Utility
I	6,700	0.7465
II	8,039	0.8122
III	8,991	0.8467
IV	9,658	0.8758



It is clear from Table 3.7 that alternative IV, that is construction of three power plants to supply the country with electricity by the year 2000, would be most preferred. This is true whether the utility values are compared or the equivalent monetary values of the alternate decisions are analyzed. This result substantiates the selection of the objective described in Section 3.3.

#### 4. ALTERNATE METHODS TO REALIZE TRANSFER OF NUCLEAR TECHNOLOGY GOALS

In Chapter 3 an objective is proposed for a first phase of the transfer of nuclear technology to Saudi Arabia. The realization of this goal; or other goals for that matter require identification of transfer channels, phases and details. Apparently, construction of nuclear power plants in nonnuclear countries will involve a great deal of discussion and qualitative guesses about the dilemma of whether to import everything required for the construction and operation of the plant including manpower or to participate wherever possible in the projects. Another predicament usually arises in those situations which evolve around the question of whether to adopt or adapt alien technologies. Although the pros and cons of each of the available alternate routes are often identified, qualitative assessments are unlikely to provide satisfactory solutions.

Nevertheless, decision and utility theories offer a methodology to quantify the attributes of planning policies as measures for the effectiveness of a given strategy. Utility or preference curves are constructed for each of the attributes to depict patterns of acceptance of each of the factors affecting the decision on available alternate strategies.

Multiattribute utility theory can be used successfully to identify the trade-off between various combinations of levels of different attributes of transferring nuclear technology to Saudi Arabia.

The assessment of the utility function of different alternatives consist of four dependent steps:

1. selection of measures of effectiveness (attributes),
2. evaluation of multiattribute model,
3. assessment of the component utility functions and
4. assessment of proper scaling factors.

#### 4.1. Measures of Effectiveness

To select one viable solution from a given set of alternatives, one needs to specify some measures of effectiveness, which explicitly describe the possible impact on the decision. The attributes that have an important impact on this nuclear technology transfer to Saudi Arabia are selected. The attributes and their range are given in Table 4.1. The attributes serve to indicate the degree to which the objectives are met (18).

The main assumption made is that the attributes are preferentially independent.

Table 4.1. Relative range of various attributes of transferring nuclear technology

Symbol	Attribute, $X_i$	Units	Range		
			Best, $X_b$	Middle, $X_m$	Worst, $X_w$
$X_1$	Time required for whole project to be done	Years	10	20	30
$X_2$	Performance of training program	Person/yr	200	100	0
$X_3$	Industrialization of the country	Subjective	100	50	0
$X_4$	Research encouragement	Subjective	100	50	0
$X_5$	Innovation enhancement	Subjective	100	50	0
$X_6$	Increase in project cost over similar project in nuclear countries	Percentage	0	250	500
$X_7$	Outside control	Percentage	0	50	100
$X_8$	Long term benefits for development	Subjective	100	50	0
$X_9$	Probability of success in achieving the goal	Prob.	1	.5	0
$X_{10}$	Harmony with ideology	Subjective	100	50	0
$X_{11}$	Compatibility with culture	Subjective	100	50	0
$X_{12}$	Safety	Prob.	1	.5	0
$X_{13}$	Quality	Subjective	100	50	0
$X_{14}$	Assurance of fuel supply	Percentage	100	50	0



Table 4.1 (Continued)

Symbol	Attribute, $X_i$	Units	Range		
			Best, $X_b$	Middle, $X_m$	Worst, $X_w$
$X_{15}$	Spin-offs	Subjective	100	50	0
$X_{16}$	Increase in GNP	Percentage/yr	100	50	0
$X_{17}$	Agreeability with public attitude	Subjective	100	50	0
$X_{18}$	Preference of decision-maker	Subjective	100	50	0
$X_{19}$	International participation	Man/million \$	10	5	0
$X_{20}$	R&D cost effectiveness	Percentage	100	50	0
$X_{21}$	Diversion potential	Percentage	0	50	100
$X_{22}$	Vulnerability to sabotage	Percentage	0	50	100

#### 4.2. Assessment of Component Utility Function

To assess a utility function, it is necessary to qualitatively determine structure that indicates functional forms appropriate for quantifying the actual function. There are two forms of the multiattribute utility function; namely

$$U(X) = \sum_{i=1}^n k_i u_i(X_i) \quad (4.1)$$

and

$$1 + KU(X) = \prod_{i=1}^n [1 + Kk_i u_i(X_i)] \quad (4.2)$$

Where  $u_i$  is the utility function corresponding to the  $i$ th attribute scaled from zero to one,  $k_i$  is the corresponding scaling constant with  $0 < k_i < 1$ . The assessment procedure for  $k_i$  is given in Section 4.3. Equation 4.1 is the additive utility function and Equation 4.2 is known as multiplicative utility function.

The value of  $K$  can be found from the values of  $k_i$ . When  $\sum k_i = 1$ , then  $K = 0$ , and Equation 4.2 reduces to the additive form of Equation 4.1. When  $\sum k_i \neq 1$ , then  $K \neq 0$  so that we can use Equation 4.2. The proof of this result is found in Keeney (19).

The component utility functions are fitted by an exponential function of the form

$$u_i(X) = A_i + B_i \text{EXP}(C_i X_i). \quad (4.3)$$

Where  $A_i$ ,  $B_i$  and  $C_i$  are constants to be evaluated for each situation from the shape of the preference or utility curves. The curves can be calculated and scaled using the following normalization conditions (19).

$$u_i(X_w) = 0 \quad (4.4)$$

$$u_i(X_b) = 1. \quad (4.5)$$

Equations 4.4 and 4.5 give the component utility at the two extreme cases; that is  $X_w$ , the value of the attribute in the worst case, and  $X_b$  is the value of the attribute in the best condition. Other values of the attributes as well as the corresponding utilities should be assessed by the decision-maker. The coefficients A, B and C for each attribute are given in Table 4.2. A computer program is used to calculate these coefficients by using Equation 4.3. The program is given in Appendix B. The utility functions are shown in Figures 4.1 through 4.22.

The general behavior of the utility curves exhibits the three distinct shapes shown in Figure 4.23

1. concave, for the risk-averse,
2. convex, for the gambler, and
3. linear, for the expected monetary valuer (EMV'er) (20).

Table 4.2. Coefficients of the component utility function  
( $U = A + Be^{CX}$ )

Attribute	A	B	C
X <sub>1</sub>	-.0918	3.7649	-.1238
X <sub>2</sub>	-1.2042	1.2042	.00302
X <sub>3</sub>	1.1494	-1.1494	-.0204
X <sub>4</sub>	-.9338	.9338	.00728
X <sub>5</sub>	-.2878	.2878	.01498
X <sub>6</sub>	1.6721	-.6721	.00182
X <sub>7</sub>	-.01969	1.0197	-.03947
X <sub>8</sub>	1.2049	-1.2049	-.01771
X <sub>9</sub>	1.0623	-1.0623	-2.8357
X <sub>10</sub>	-.04509	.04509	.03143
X <sub>11</sub>	-.2682	.2682	.01554
X <sub>12</sub>	1.0492	-1.0492	-3.0599
X <sub>13</sub>	-.0245	.0245	.0373
X <sub>14</sub>	2.2042	-2.2042	-.00604
X <sub>15</sub>	1.092	-1.092	-.0247
X <sub>16</sub>	1.1782	-1.1782	-.01889
X <sub>17</sub>	1.7429	-1.7429	-.00853
X <sub>18</sub>	-.6445	.6445	.00937
X <sub>19</sub>	1.1681	-1.1681	-.19388
X <sub>20</sub>	1.0811	-1.0811	-.0259
X <sub>21</sub>	-.0087	1.0087	-.0475
X <sub>22</sub>	-.0028	1.0028	-.0589



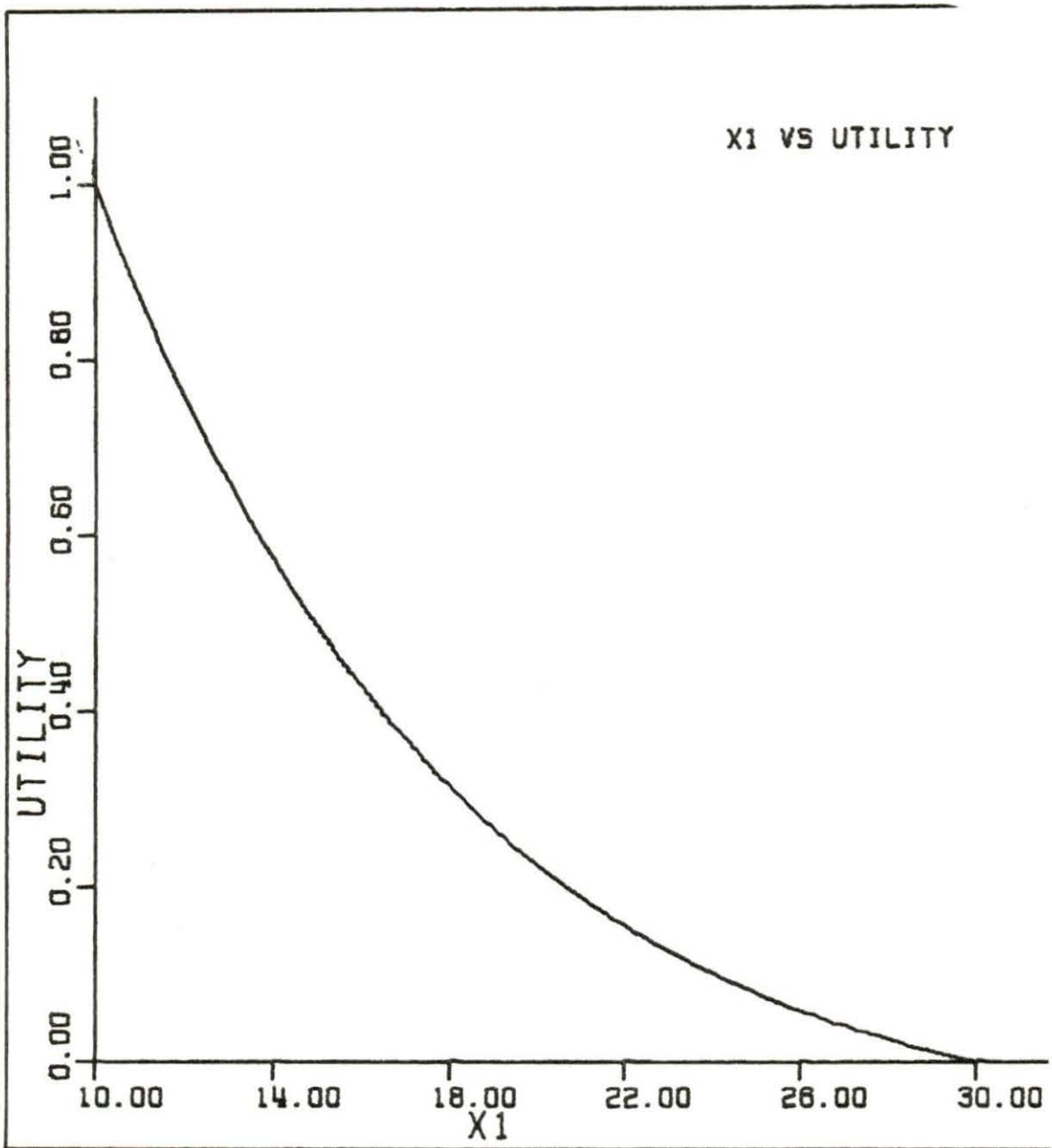

Figure 4.1. Component utility function for time required for whole project to be done (years)

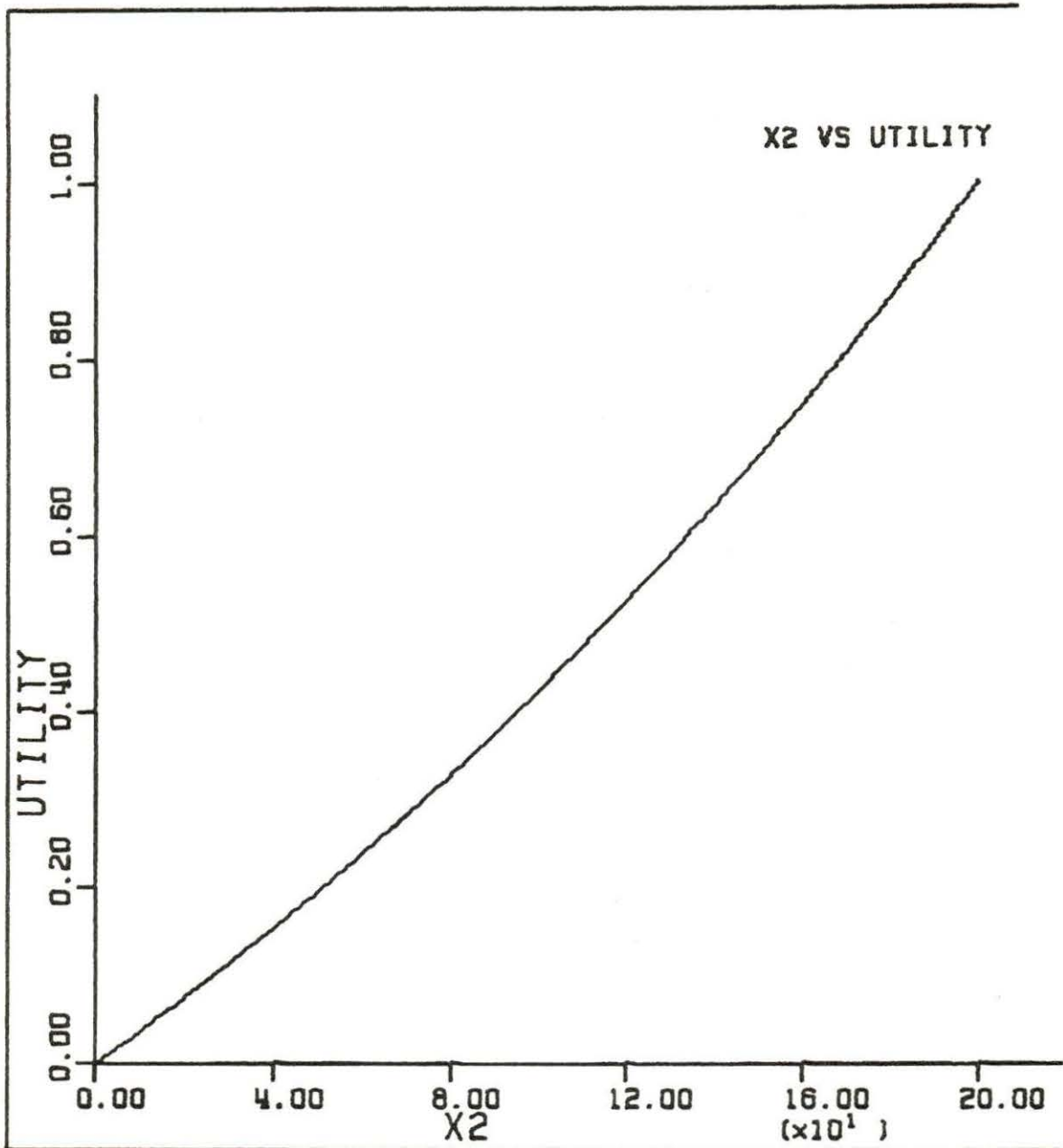

Figure 4.2. Component utility function for performance of training program (person per year)

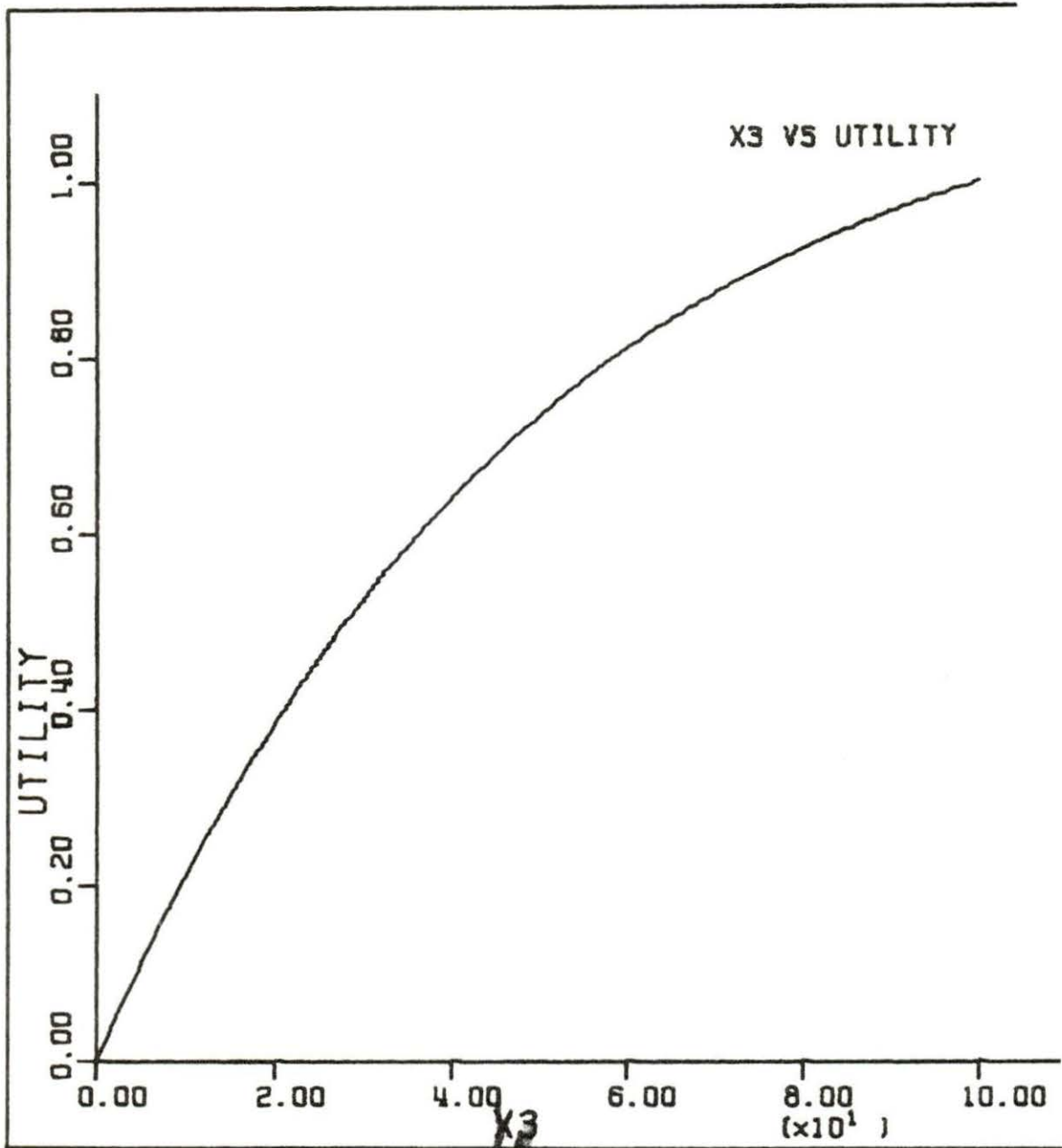

Figure 4.3. Component utility function for industrialization of the country (subjective)

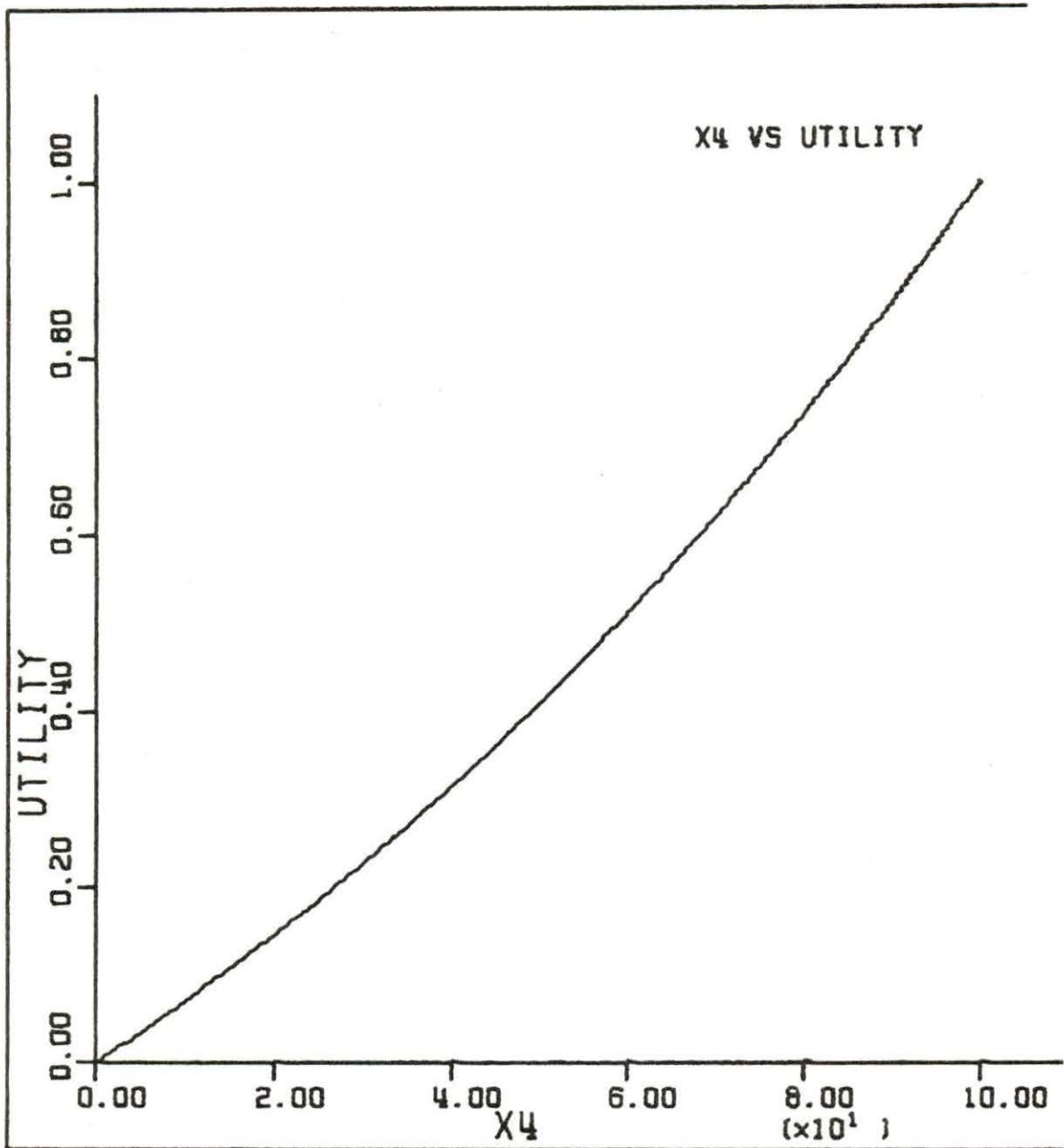

Figure 4.4 Component utility function for research encouragement (subjective)



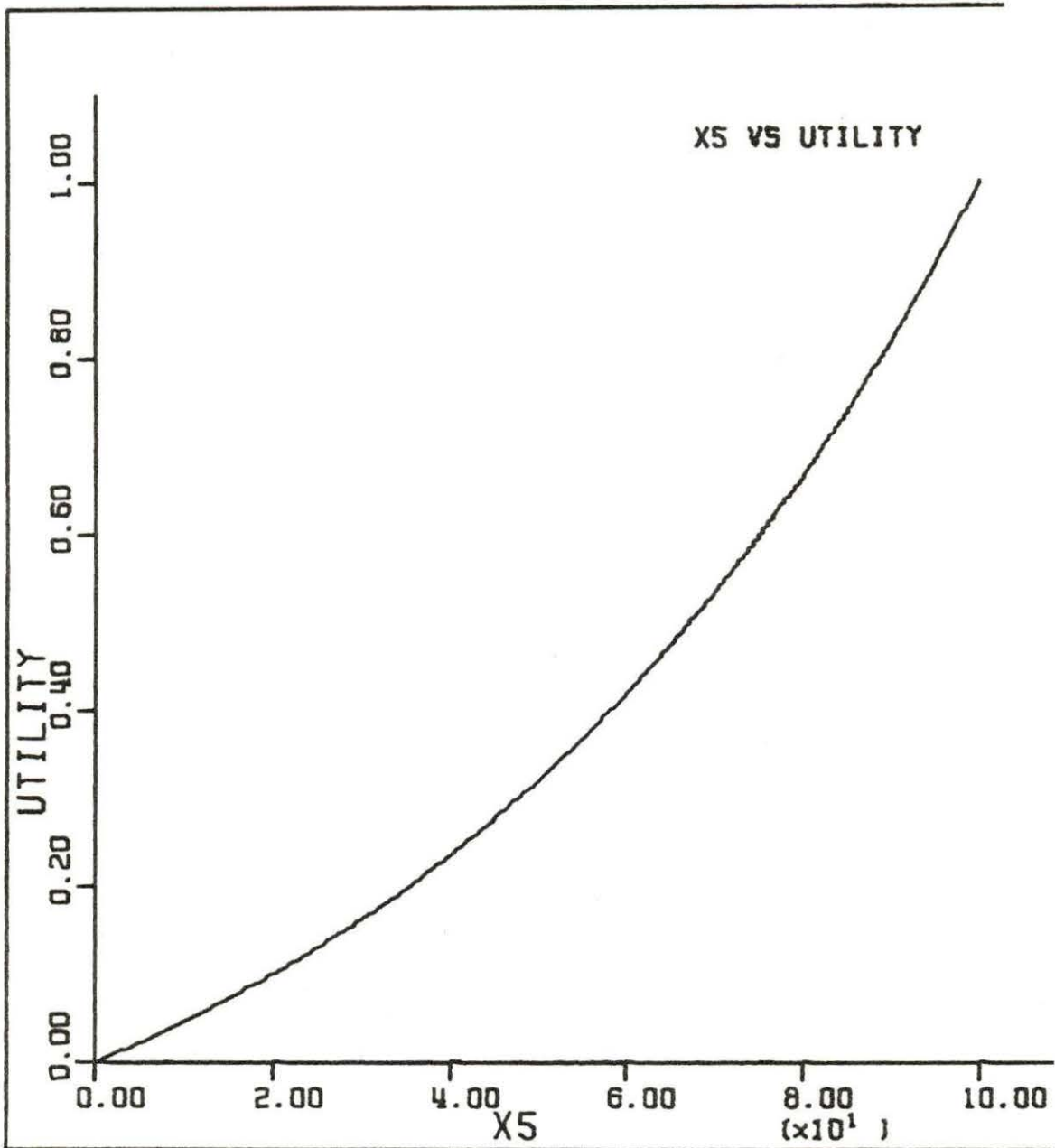

Figure 4.5. Component utility function for innovation enhancement (subjective)

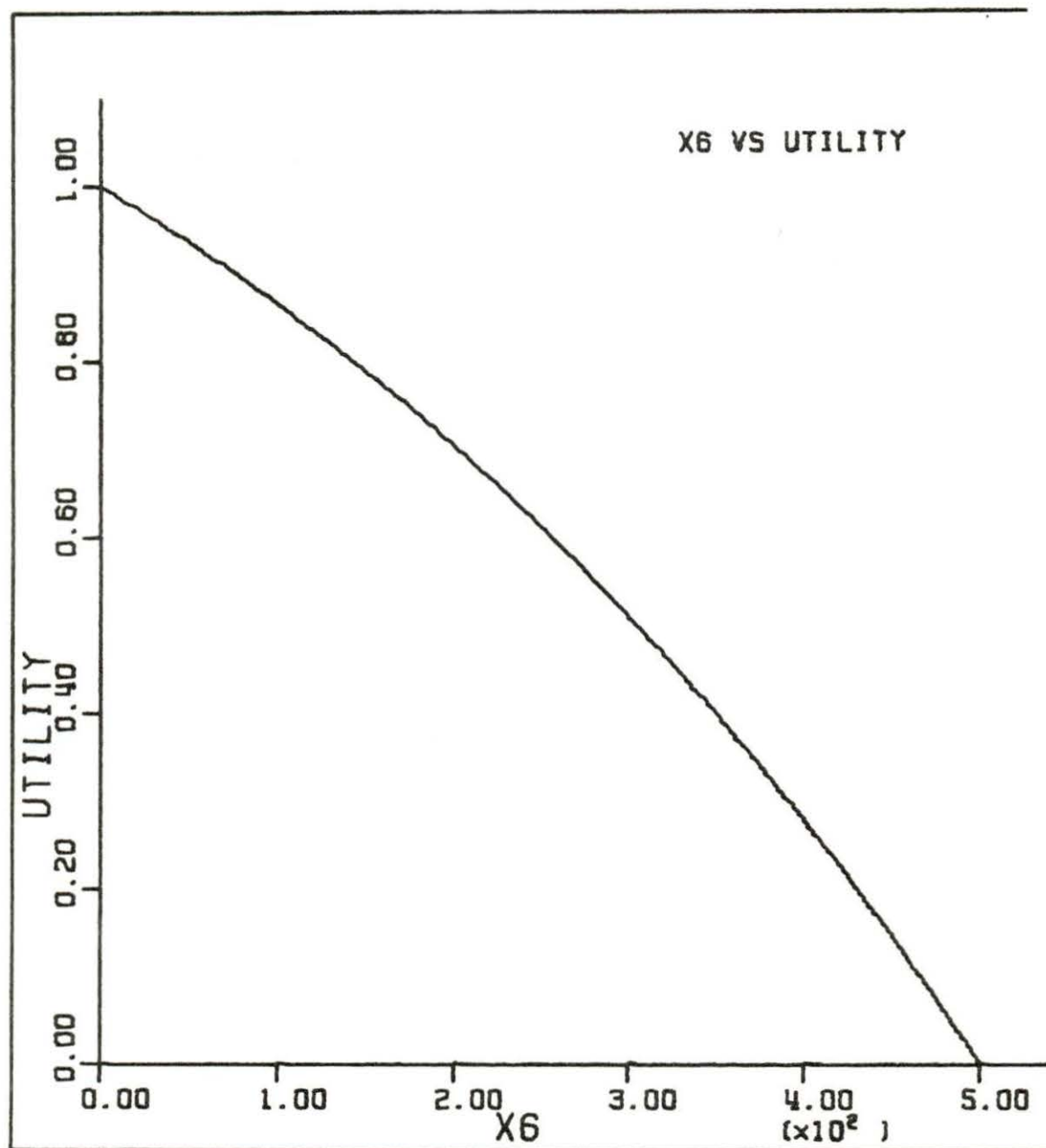

Figure 4.6. Component utility function for increase in project cost over similar project in nuclear countries (percentage)

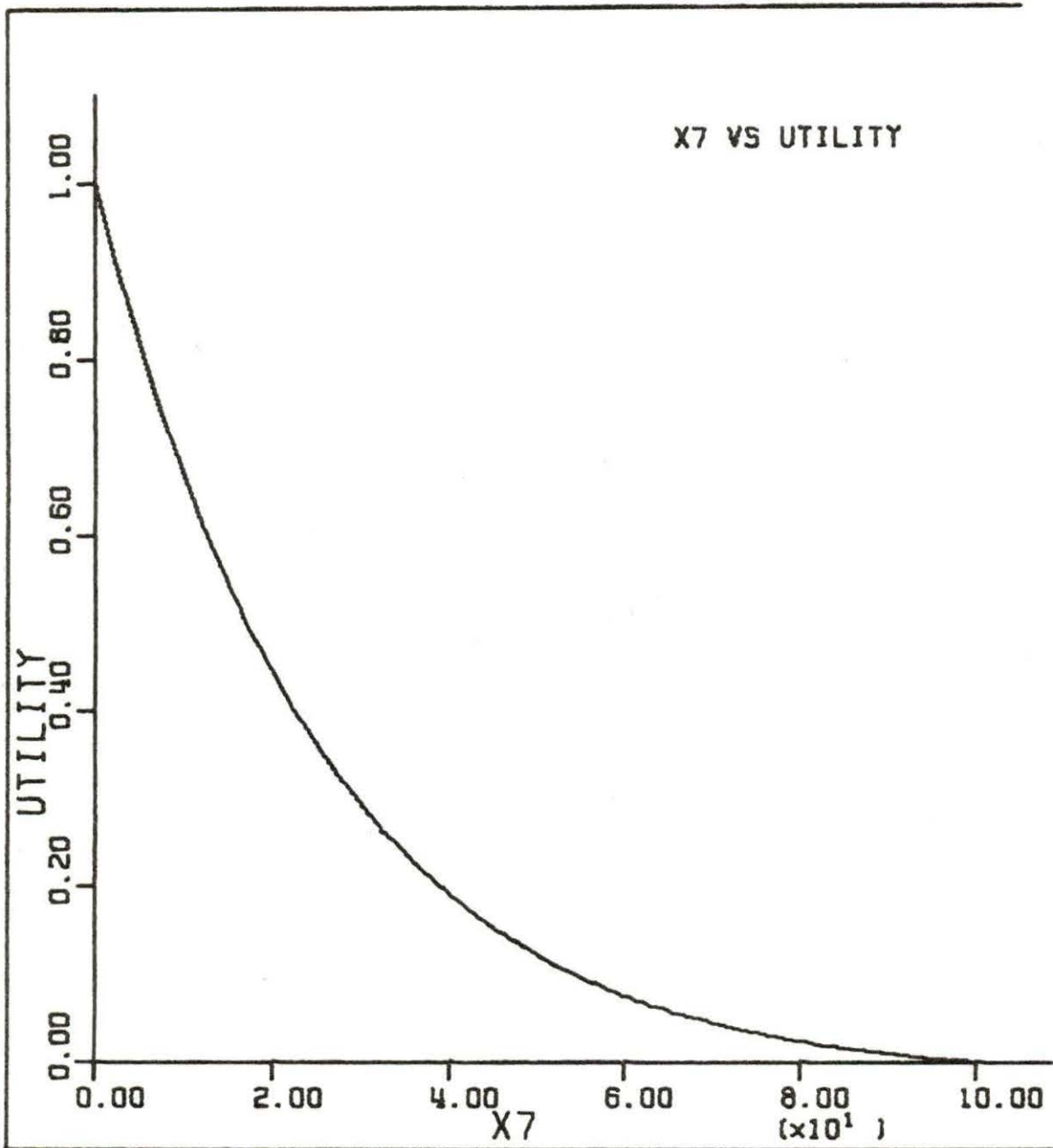

Figure 4.7. Component utility function for outside control (percentage)

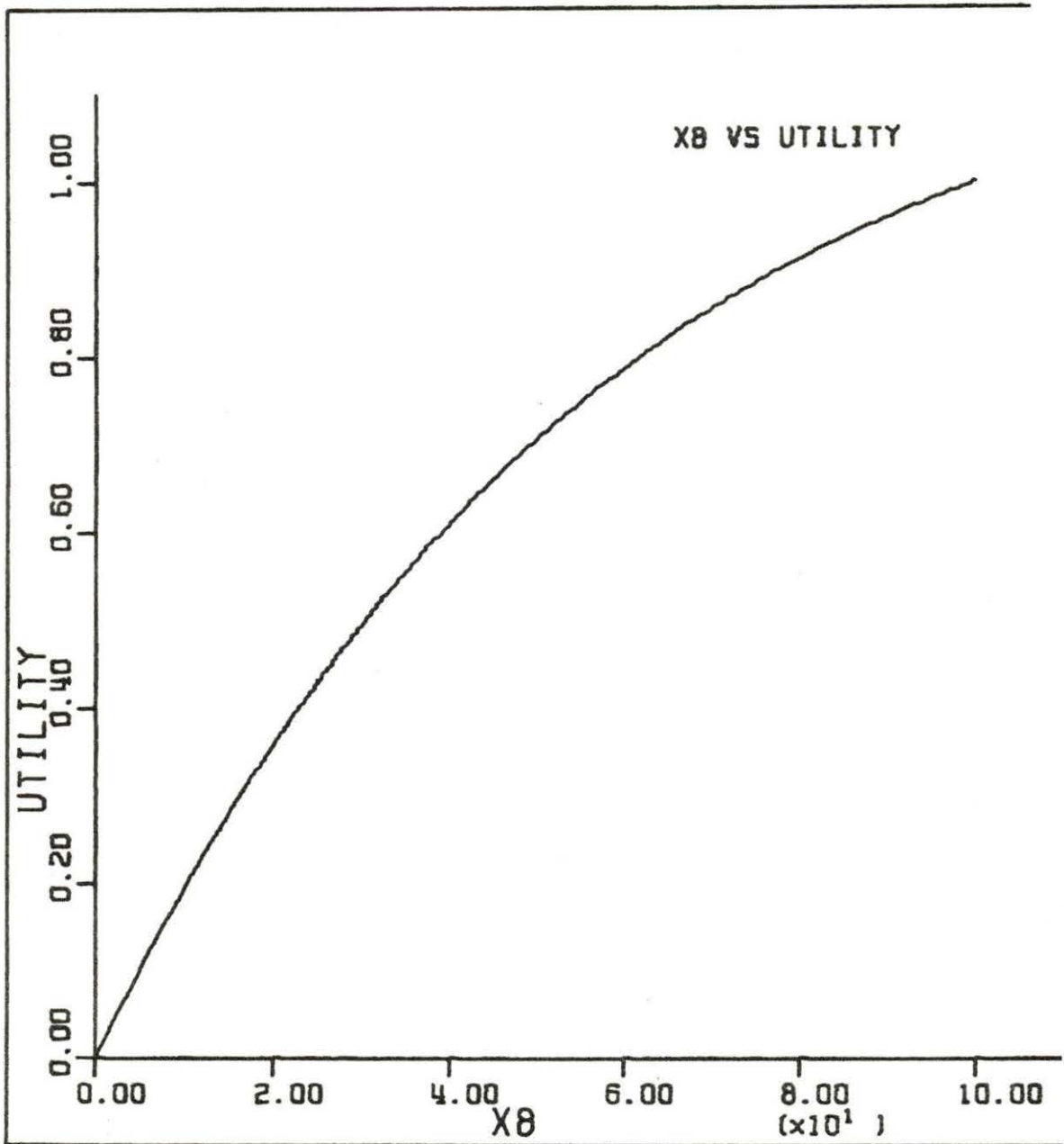

Figure 4.8. Component utility function for long term benefits for development (subjective)



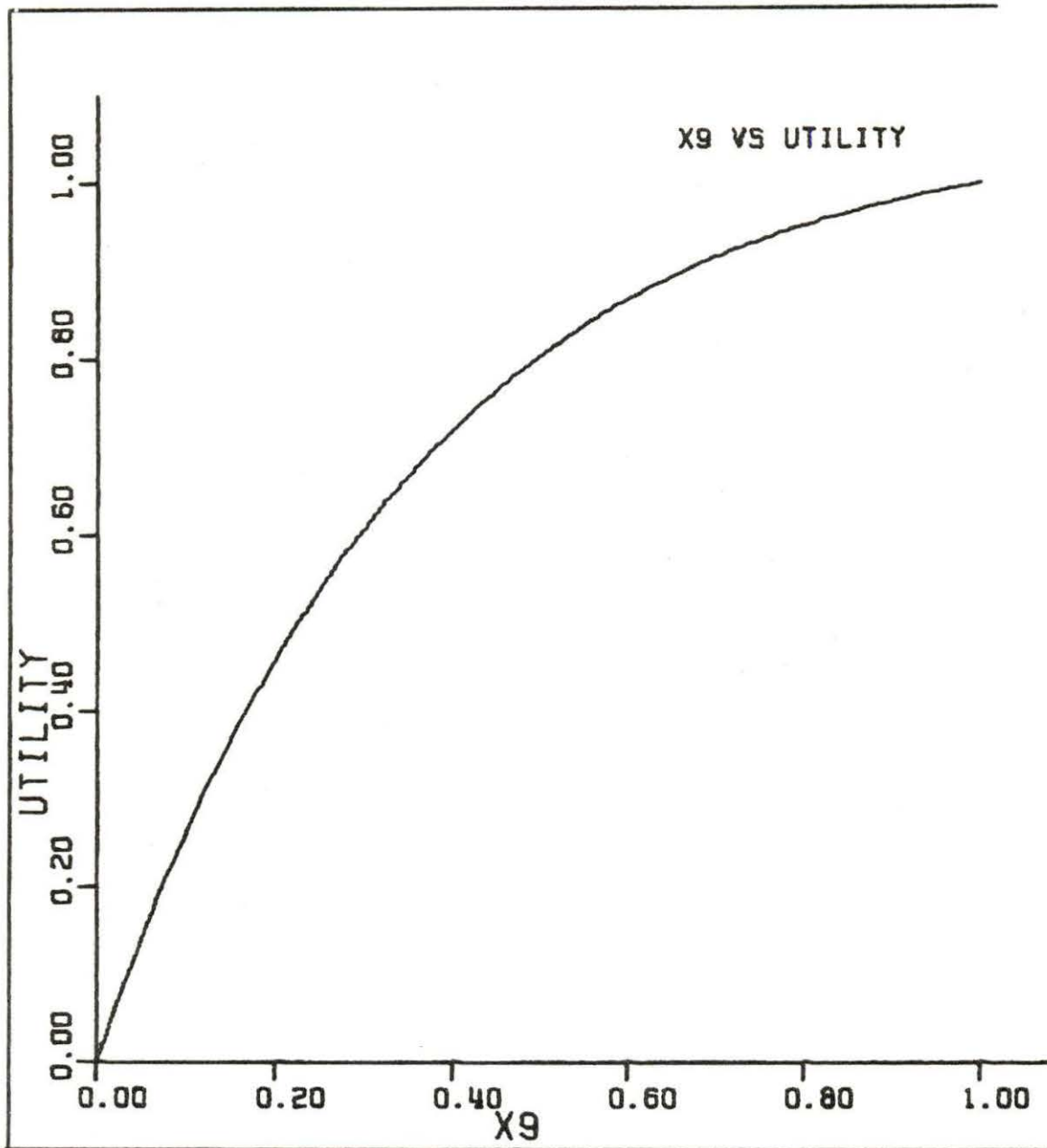

Figure 4.9. Component utility function for probability of success in achieving the goal (probability)

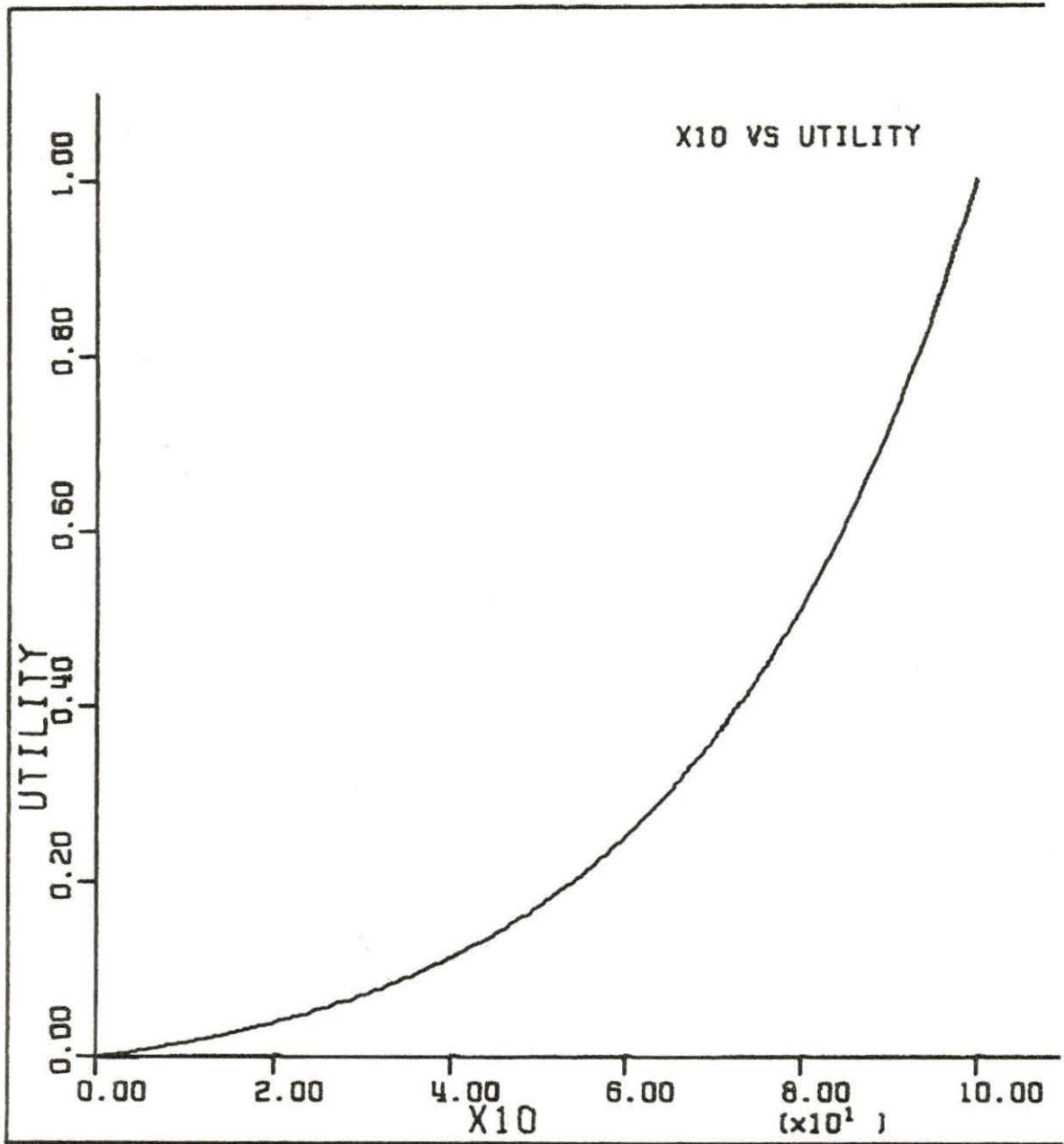

Figure 4.10. Component utility function for harmony with ideology (subjective)

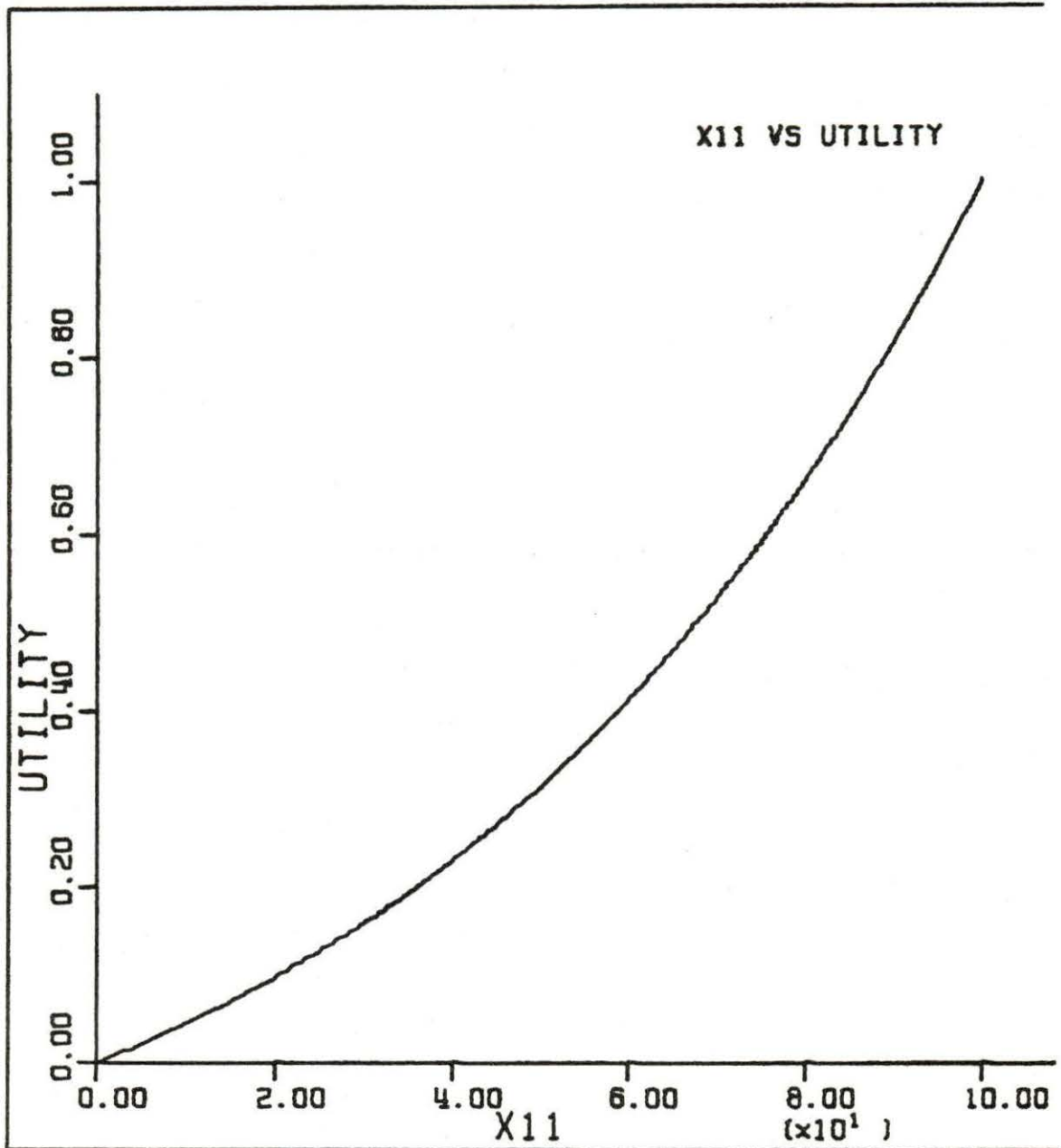

Figure 4.11. Component utility function for compatibility with culture (subjective)

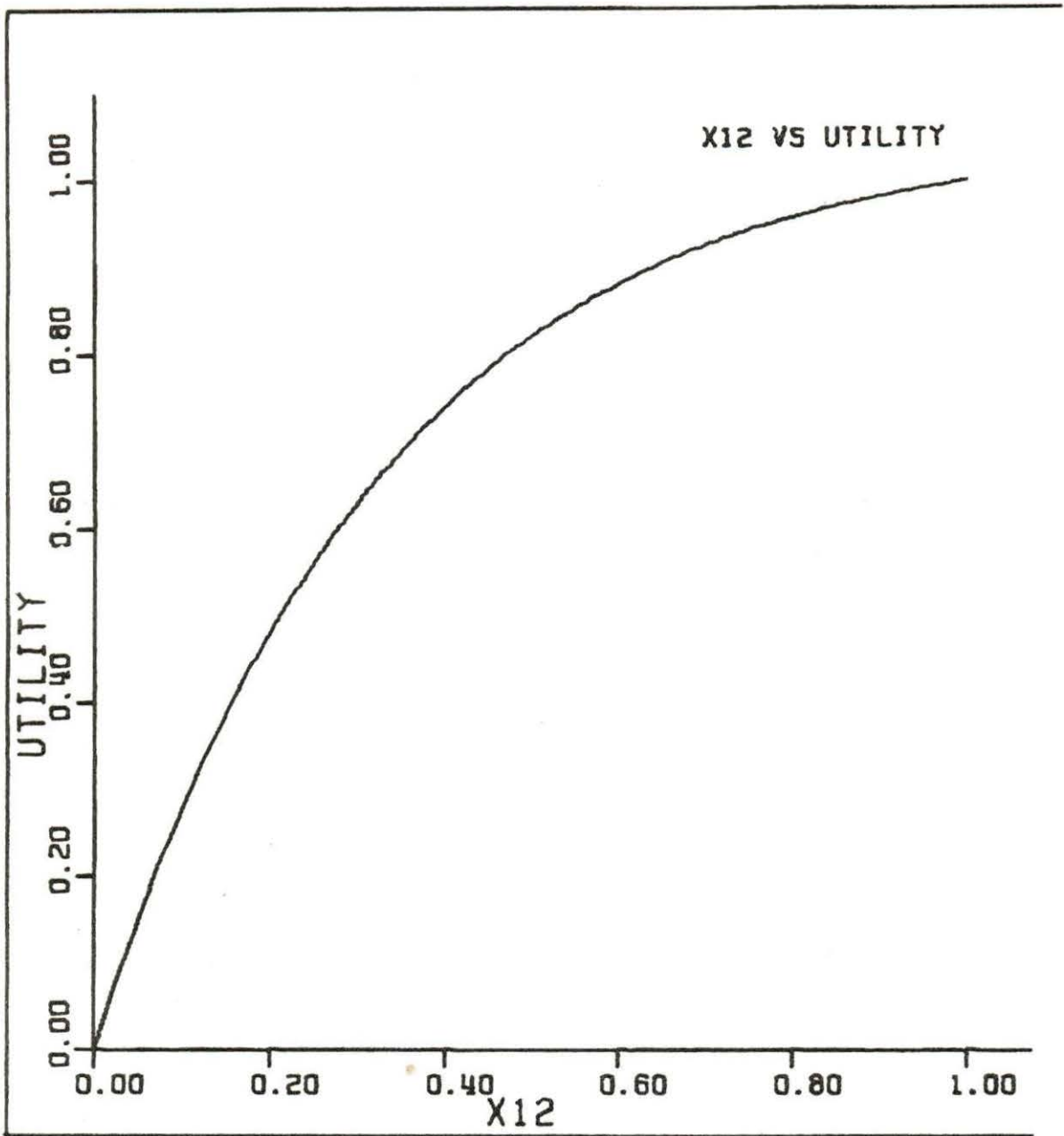

Figure 4.12. Component utility function for safety (probability)



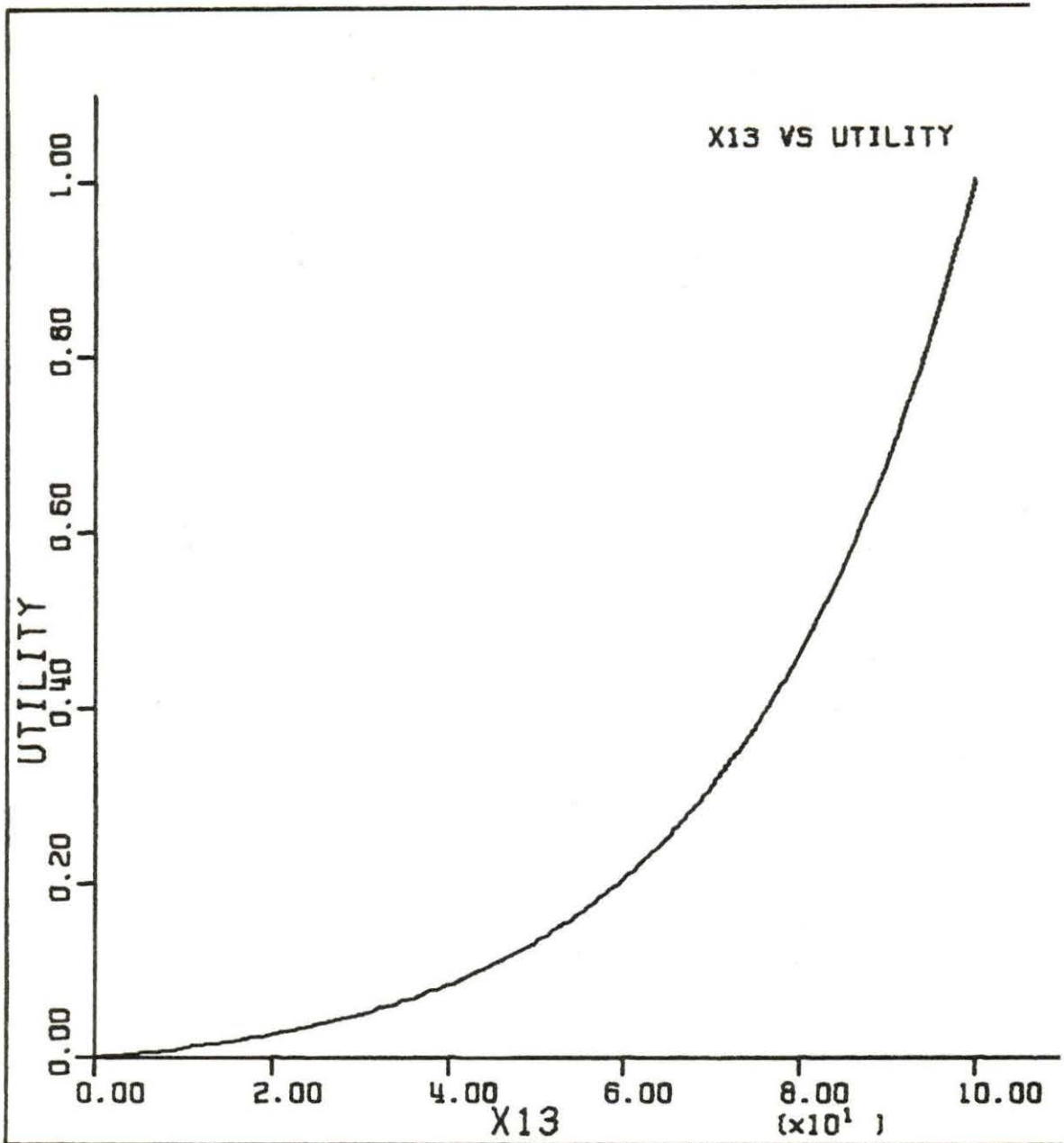

Figure 4.13. Component utility function for quality (subjective)

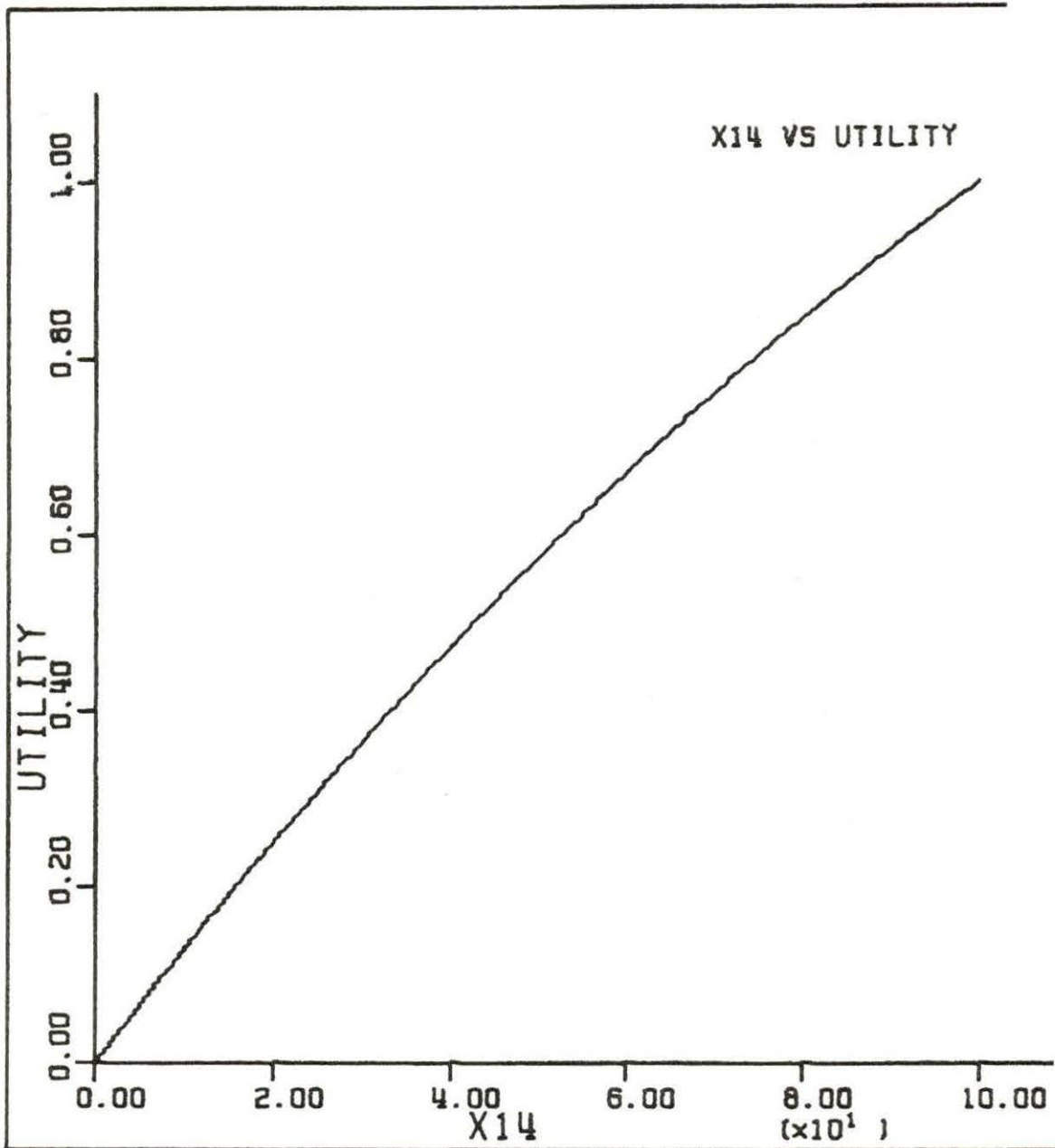

Figure 4.14. Component utility function for assurance of fuel supply (percentage)

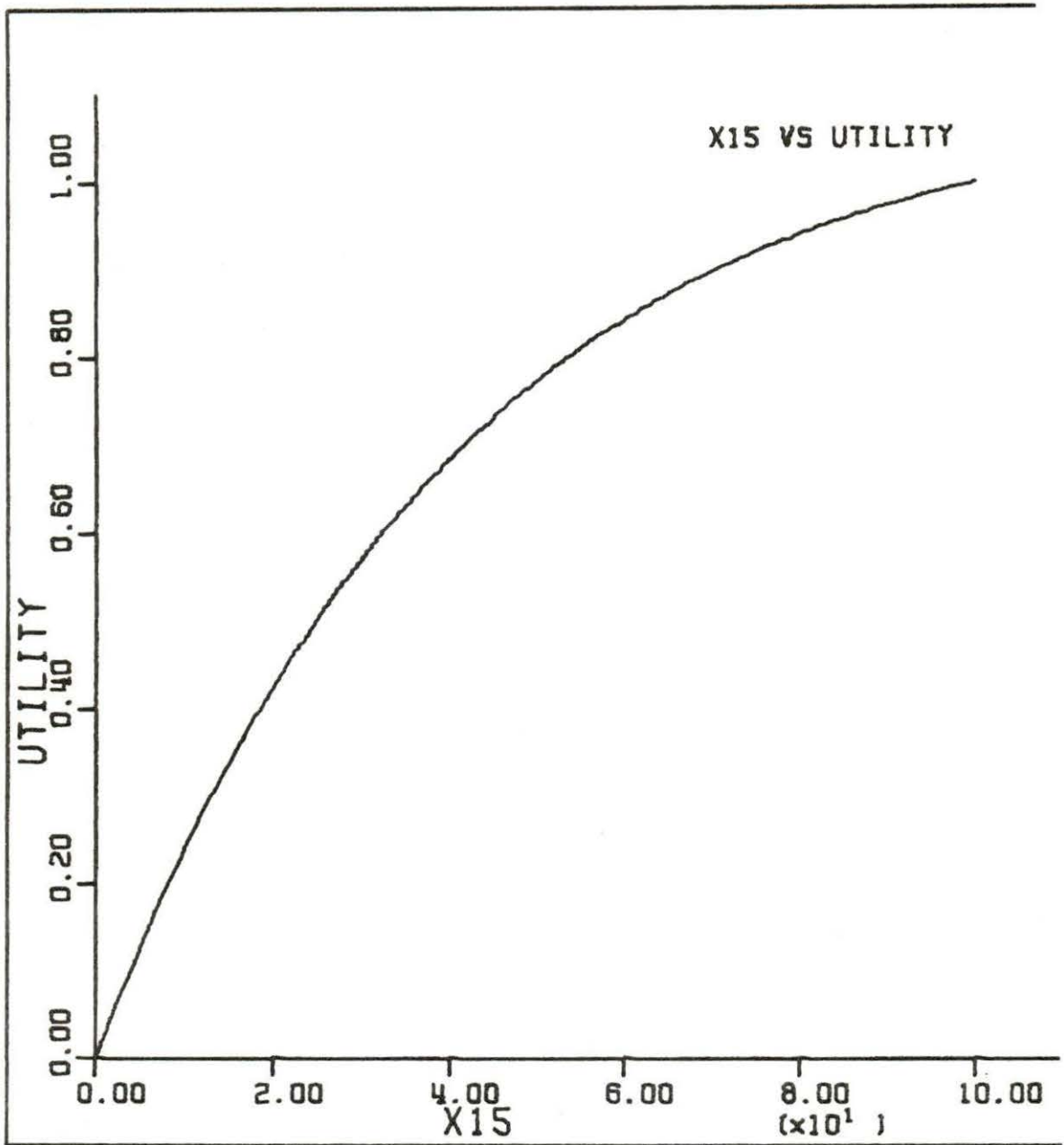

Figure 4.15. Component utility function for spin-offs (subjective)

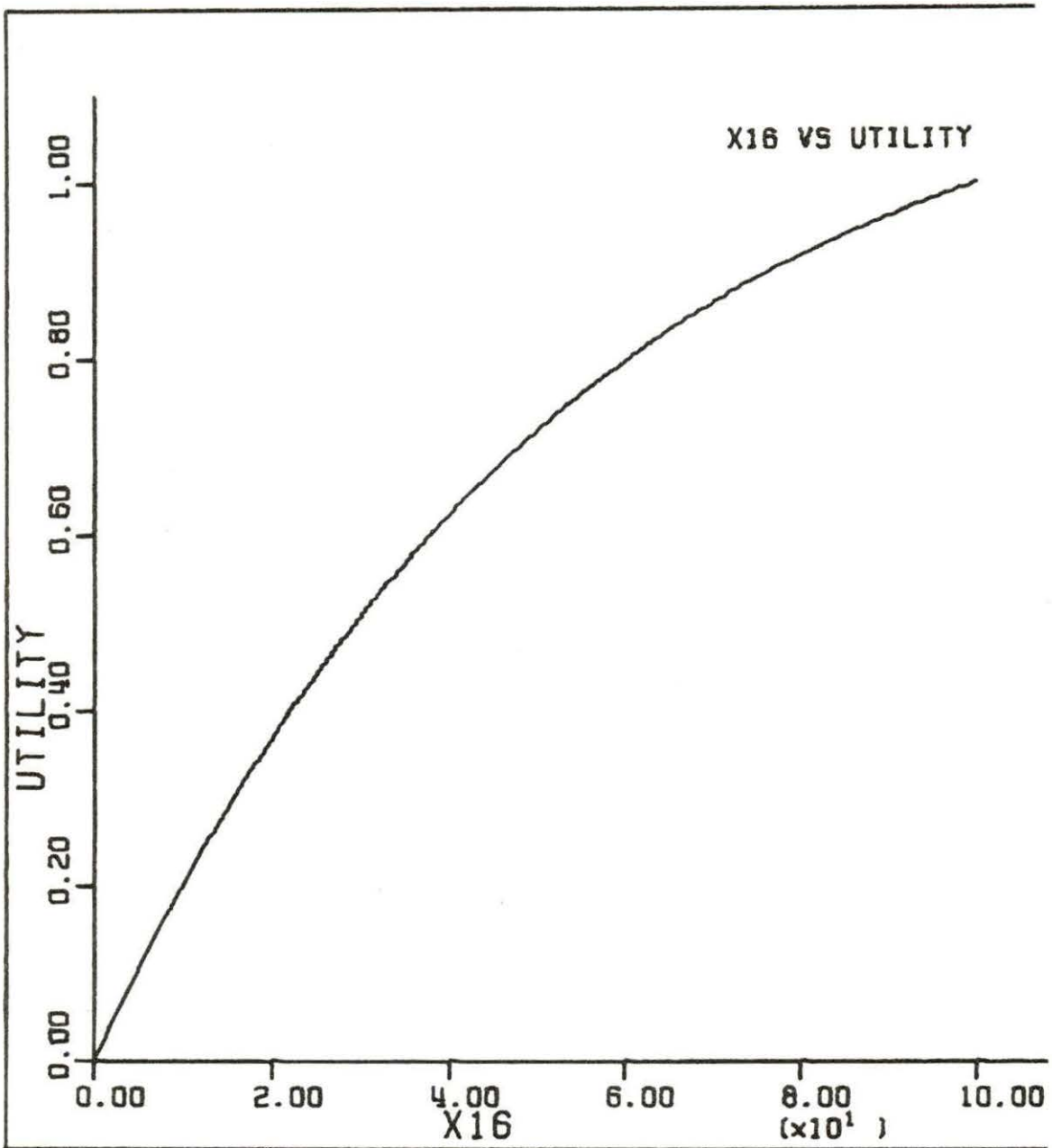

Figure 4.16. Component utility function for increase in GNP (percentage per year)



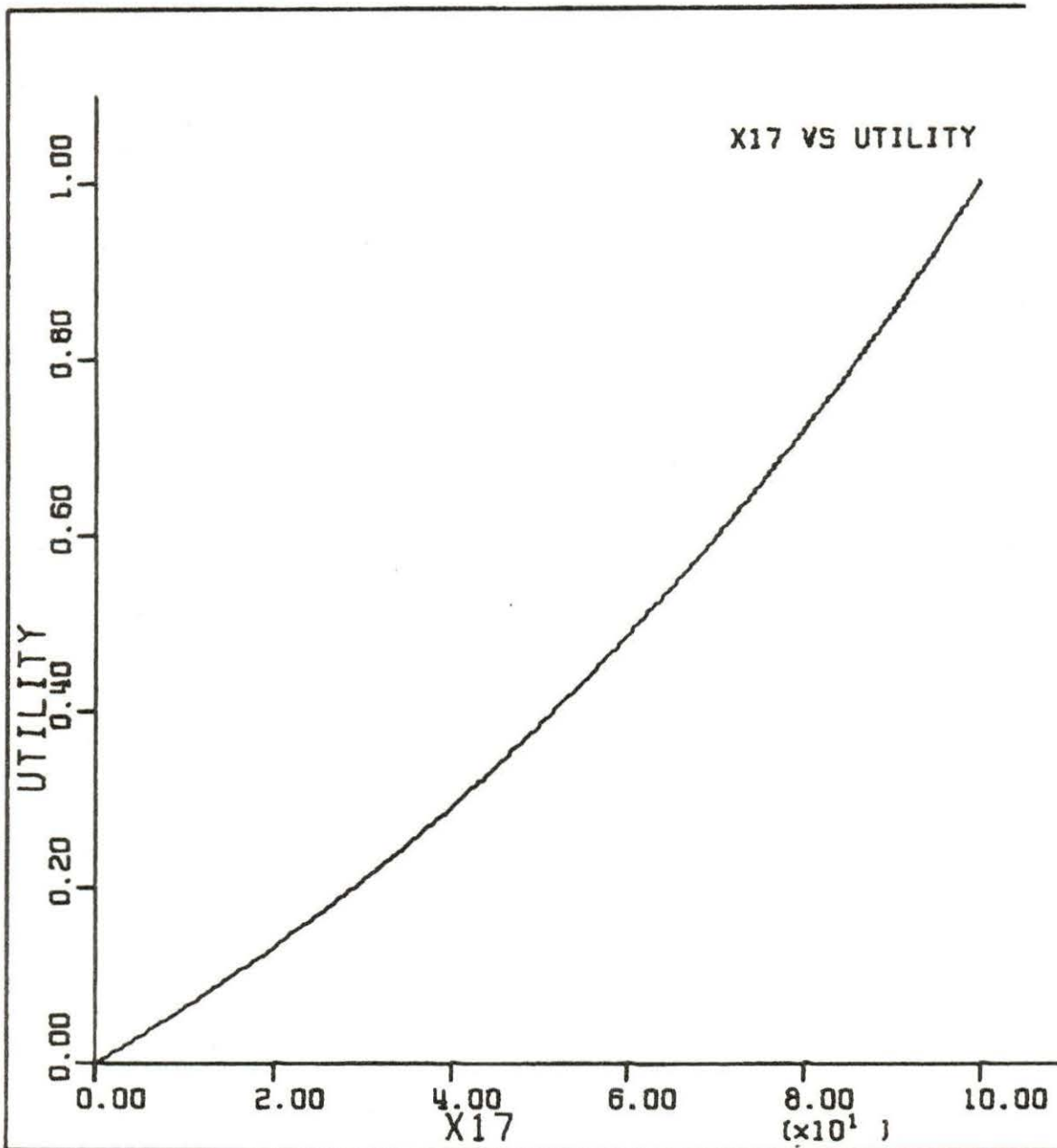

Figure 4.17. Component utility function for agreeability with public attitude (subjective)

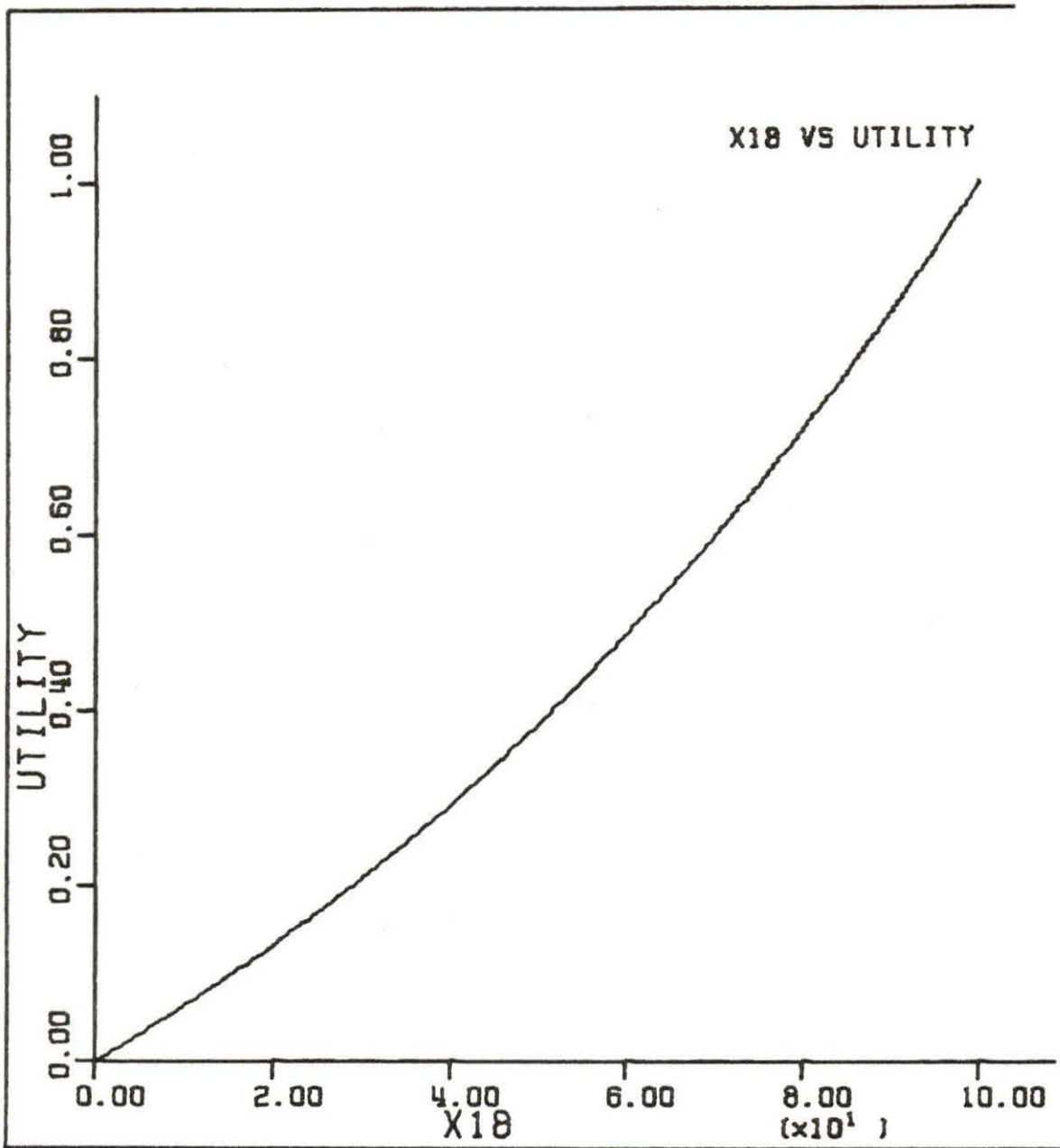

Figure 4.18. Component utility function for preference of decision-maker (subjective)

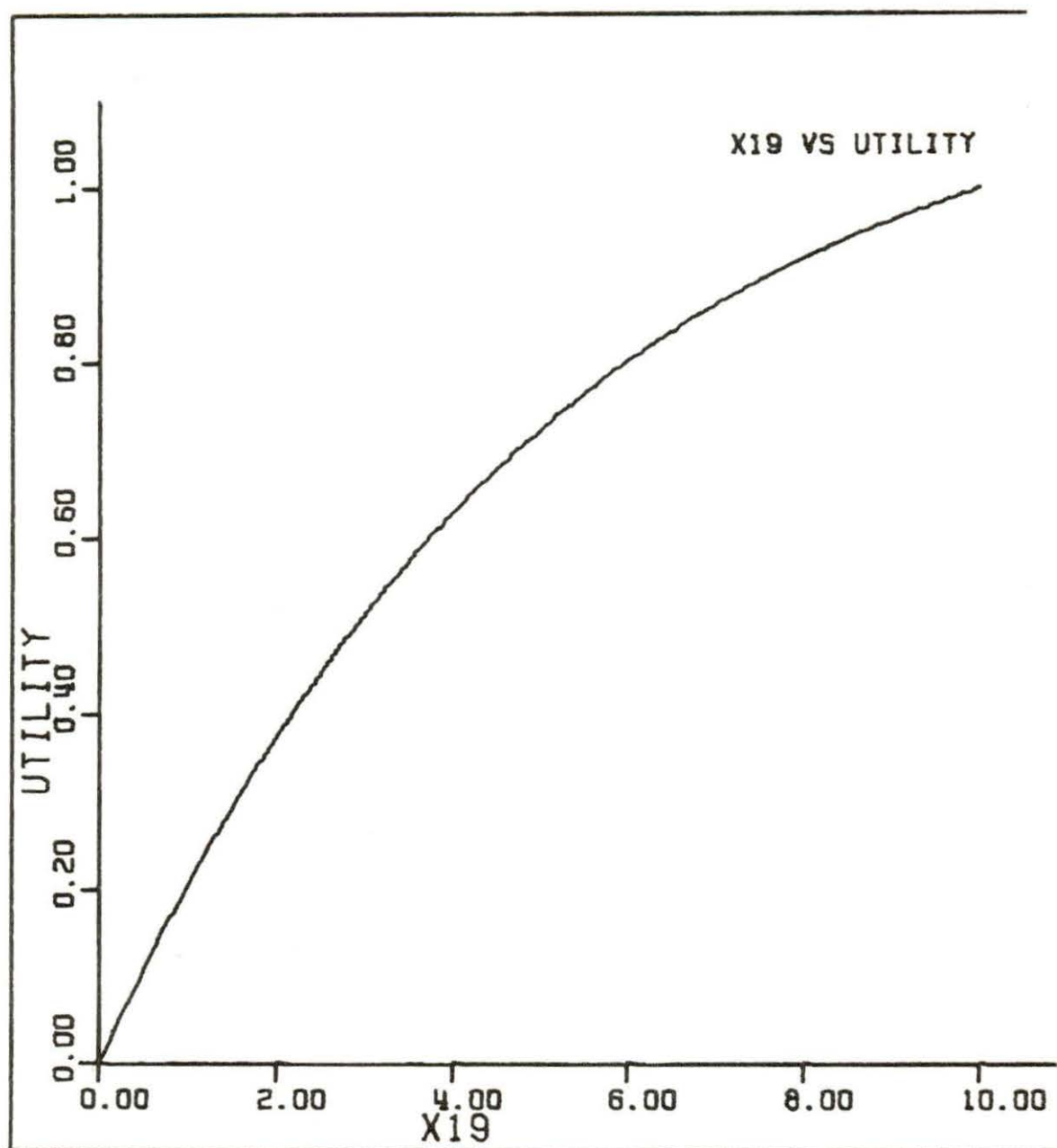

Figure 4.19. Component utility function for international participation (man per millions (\$))

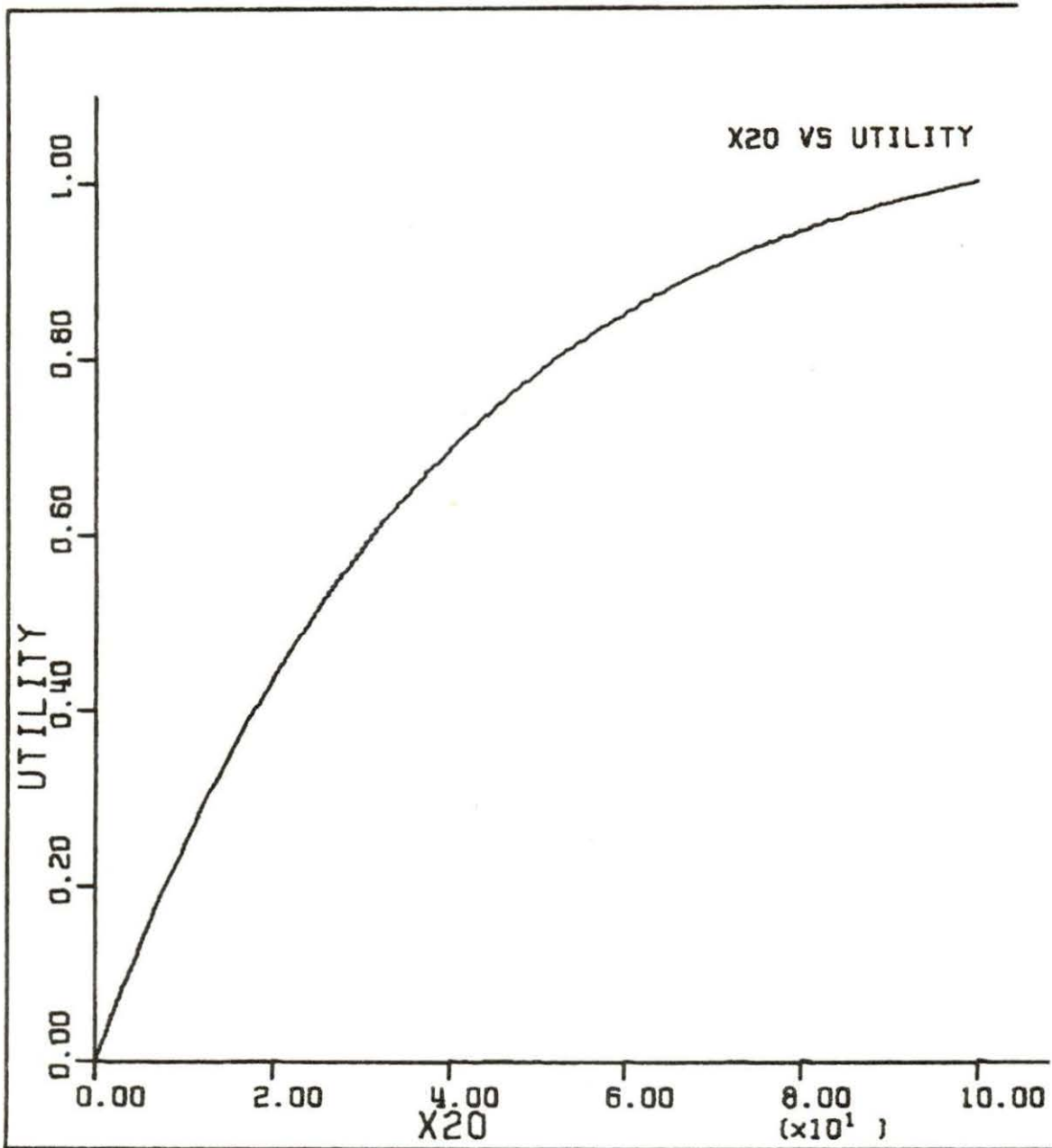

Figure 2.20. Component utility function for R&D cost effectiveness (percentage)



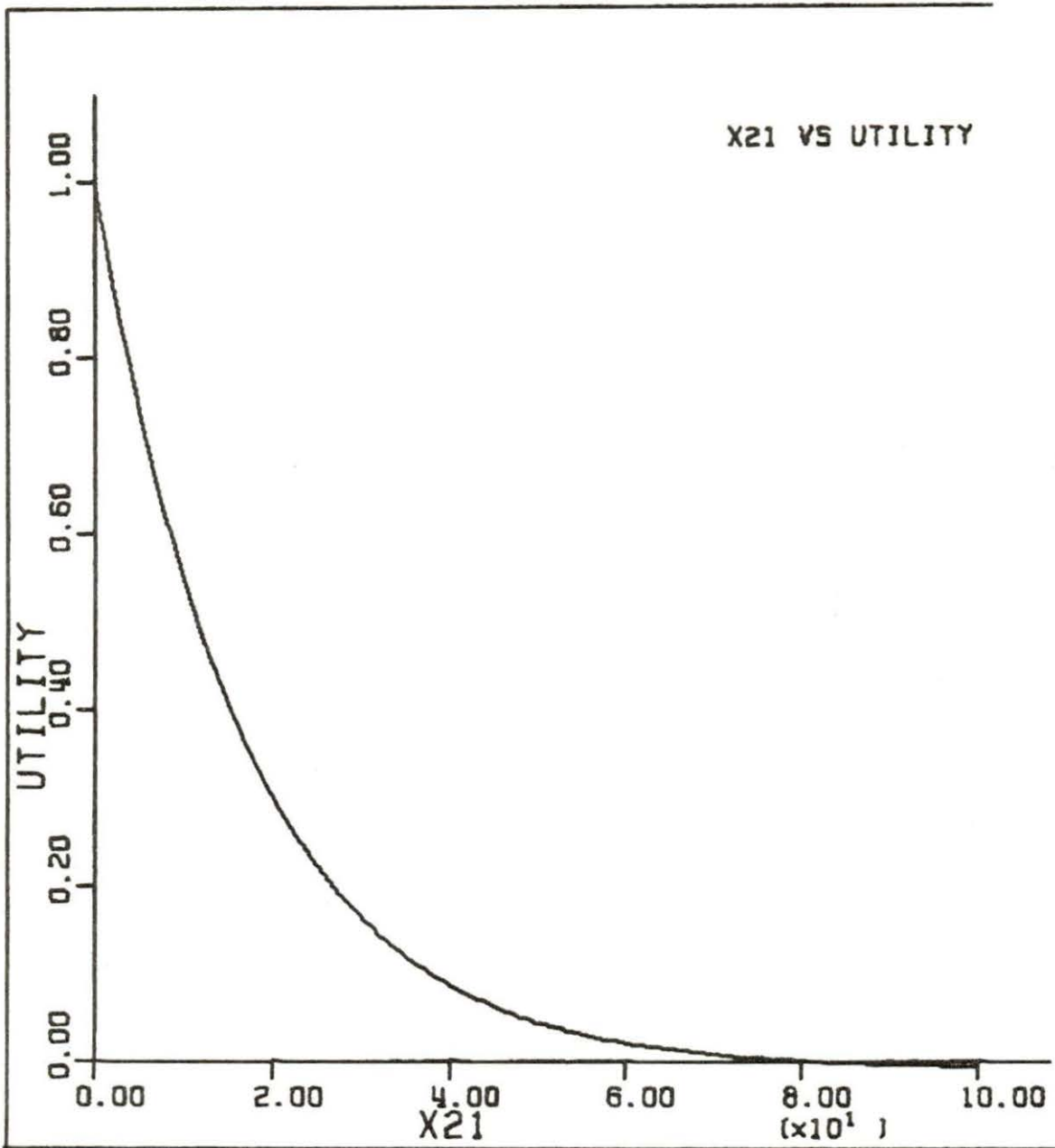

Figure 4.21. Component utility function for diversion potential (percentage)

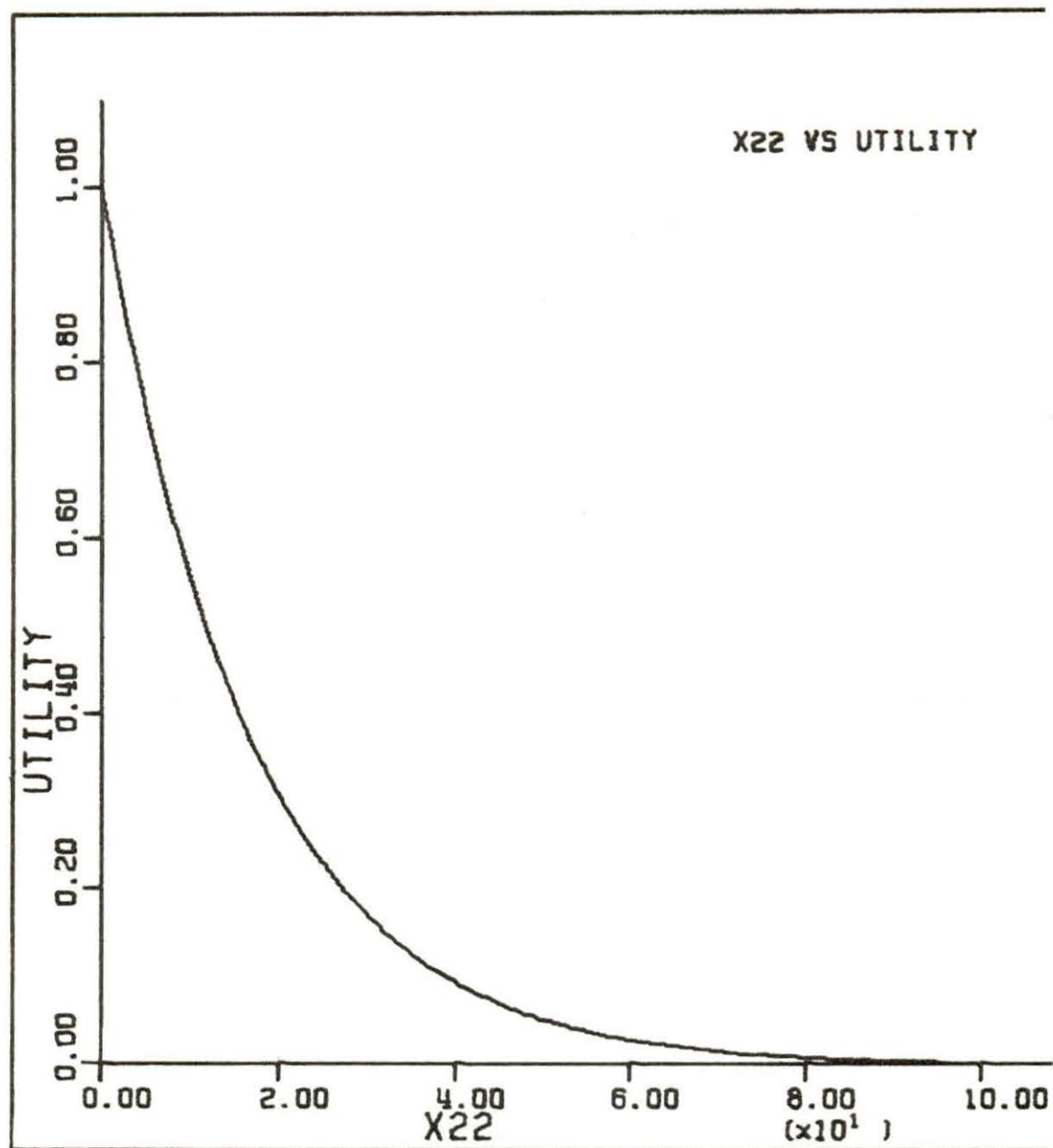

Figure 4.22. Component utility function for vulnerability to sabotage (percentage)

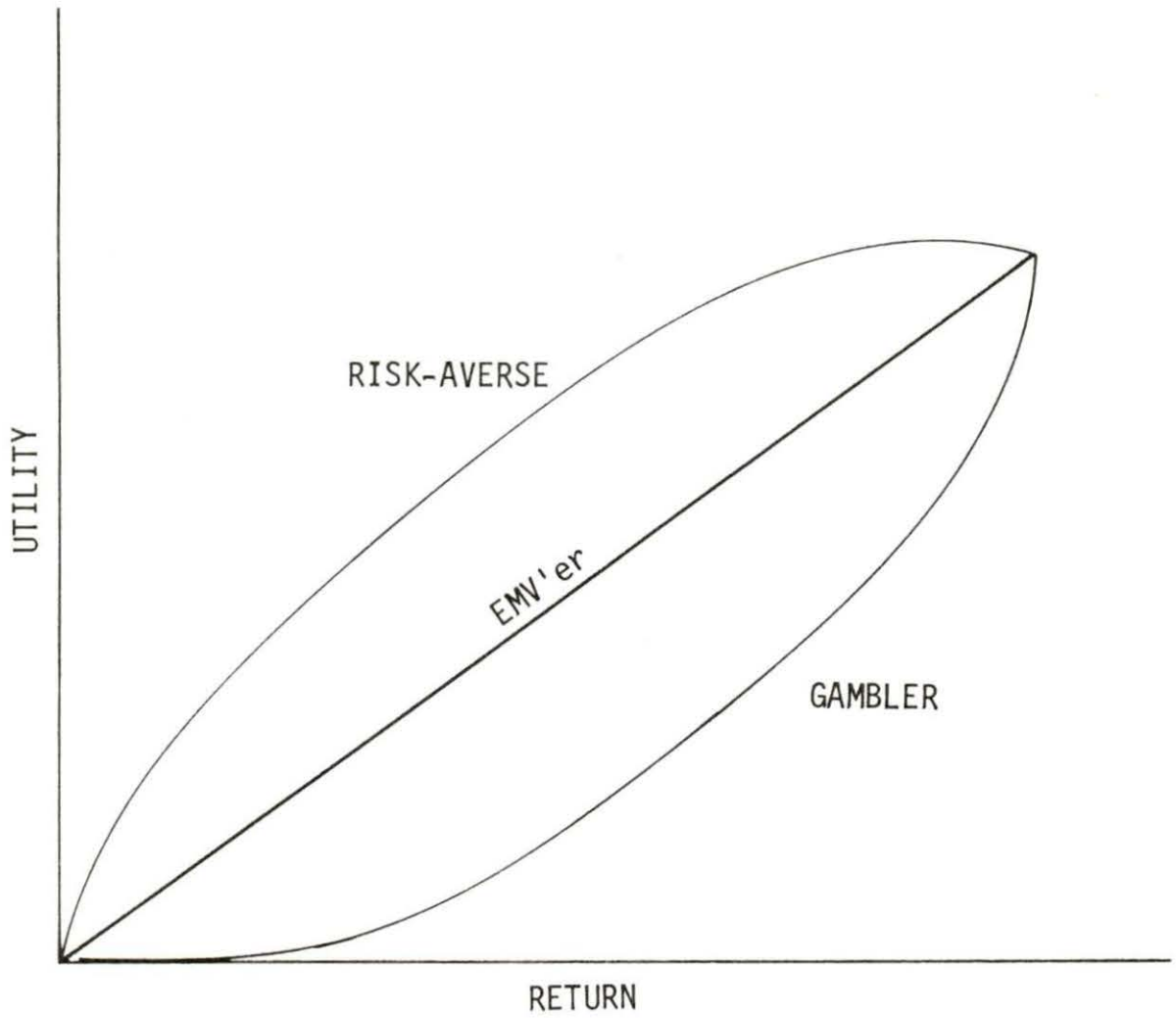

Figure 4.23. General types of utility curves (21)

By using the above definitions, it is clear that the utility curves in Figures 4.1, 4.2, 4.4, 4.5, 4.7, 4.10, 4.11, 4.12, 4.13, 4.18, 4.21, and 4.22 represent what is called "gambler curves". Figures 4.3, 4.6, 4.8, 4.9, 4.14, 4.15, 4.16, 4.17, 4.19, and 4.20 represent "risk-averse curves".

### 4.3. Scaling Factors

#### 4.3.1. Scaling of attributes, $k_i$

The first step in evaluating the scaling factors  $k_i$ , is to order their magnitude. To do that, all the attributes given in Table 2.1 are set at their worst levels  $u_i(X_{iw})$ , and a question is asked, "If only one could be raised to its best level, which one would be preferred?" (22).

This point can be expressed as:

$$u_i(X_{ib}, X_{iw}^-) = k_i \quad (4.6)$$

where the sign - is used to indicate that all attributes other than the  $i$ th attribute are at their lowest level.

Thus, to assess  $k_i$ , the decision-maker can be asked for a probability  $p_i$  such that he becomes indifferent between  $(X_{ib}, X_{iw}^-)$  and a lottery yielding either  $x_b$  with probability  $P_i$  or  $X_w$  with probability  $(1-P_i)$ . The result is known from Equations 4.4. and 4.5; that



is  $u_i(X_b) = 1$ , and  $u_i(X_w) = 0$ .

It follows that

$$u_i(X_{ib}, X_{iw}) = P_i = k_i . \quad (4.7)$$

Assuming the decision-maker is an expected utility maximizer,

$$u_i(X_i) = P_i u_i(X_b) + (1 - P_i) u_i(X_w) = P_i . \quad (4.8)$$

Thus, the probability  $P_i$  provides an appropriate utility measure. It can be easily shown that  $k_i$  must be equal to  $P_i$  (23).

After several adjustments, the following result is obtained for  $k_i$ :

$$k_{18} > k_1 > k_2 > k_3 > k_{10} > k_{12} = k_9 > k_{22} >$$

$$k_{13} > k_4 > k_{20} > k_8 > k_{14} > k_7 = k_{17} >$$

$$k_5 > k_{15} > k_6 = k_{11} > k_{16} > k_{19} > k_{21} .$$

The numerical values of the scaling factors are calculated by using the lotteries presented in Figure 4.24. Table 4.3 is given to explain the meaning of the symbols used in previous lotteries.

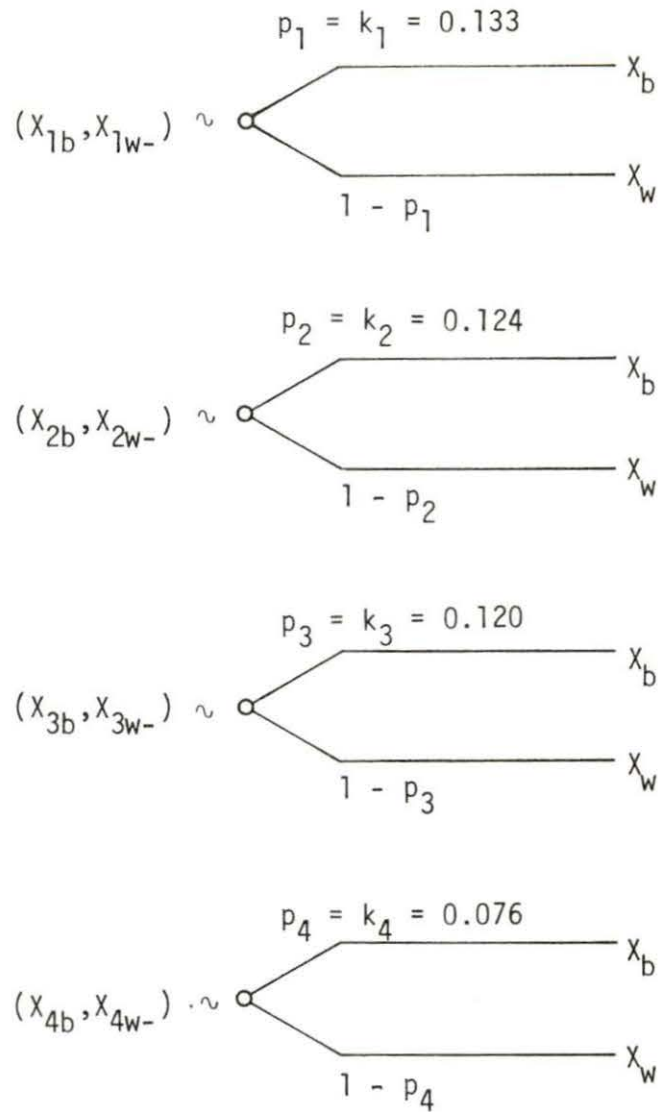

Figure 4.24. Lotteries for determining the component scaling factors,  $k_i$

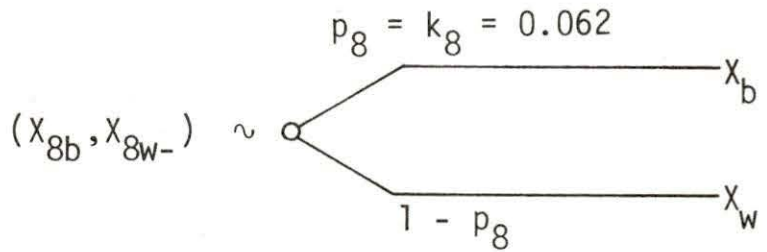
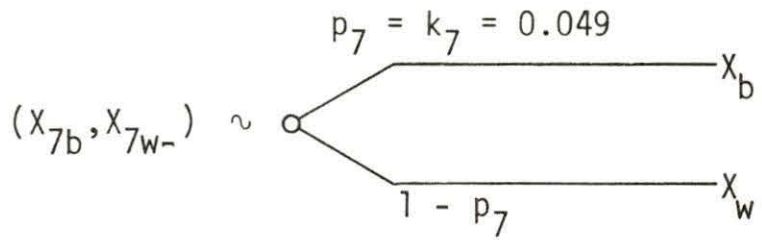
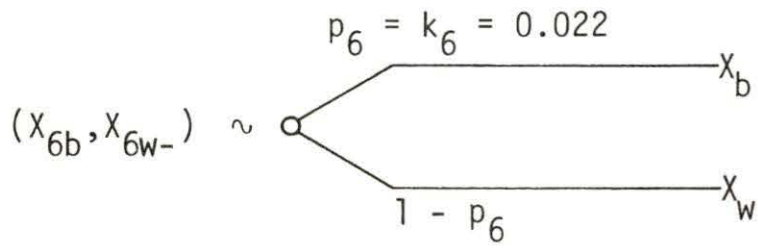
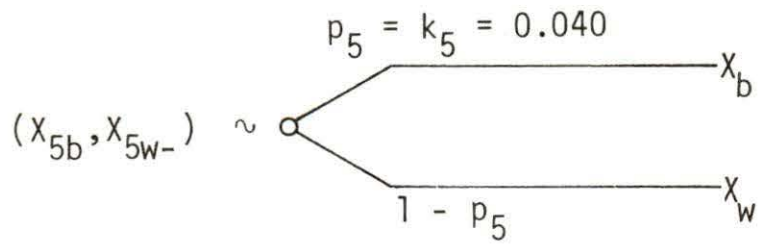

Figure 4.24 (Continued)

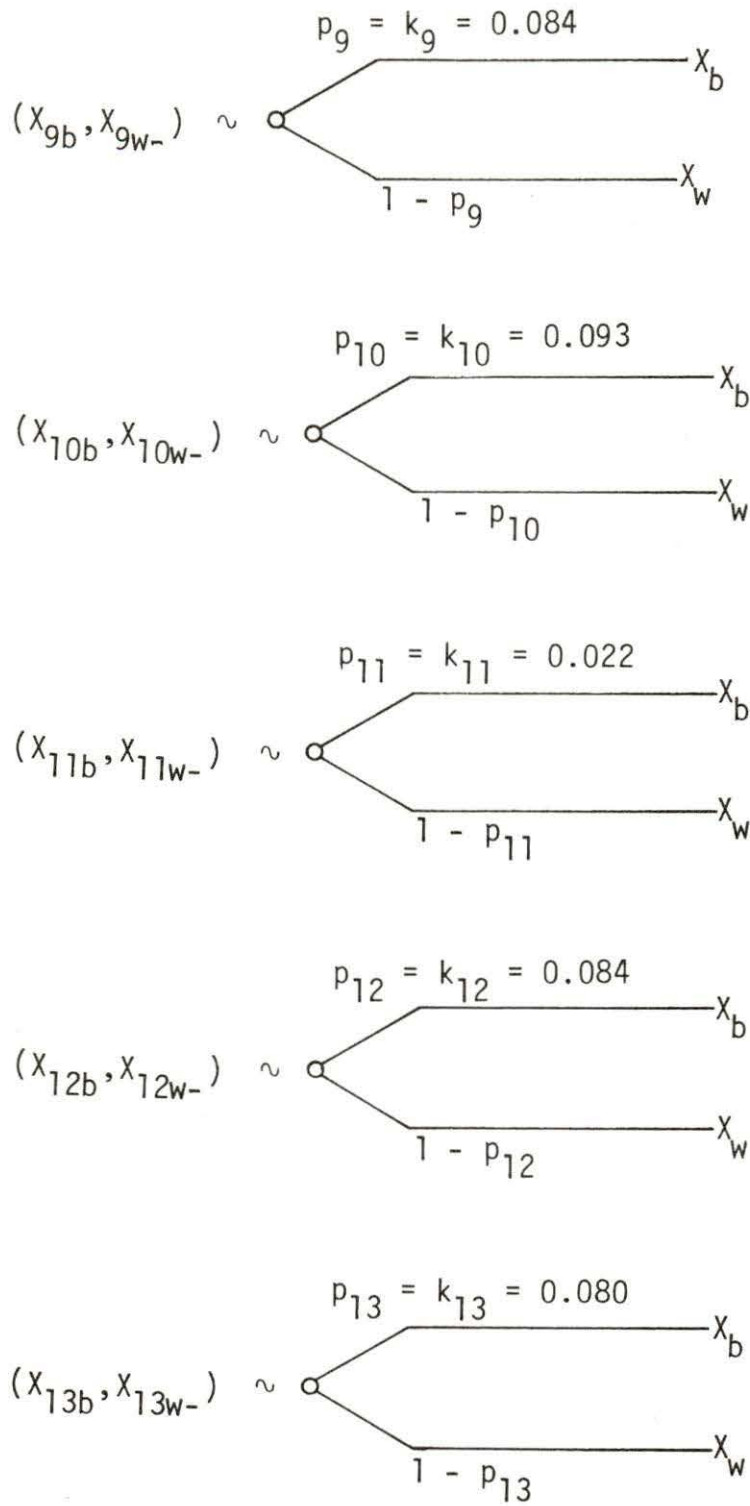

Figure 4.24 (Continued)



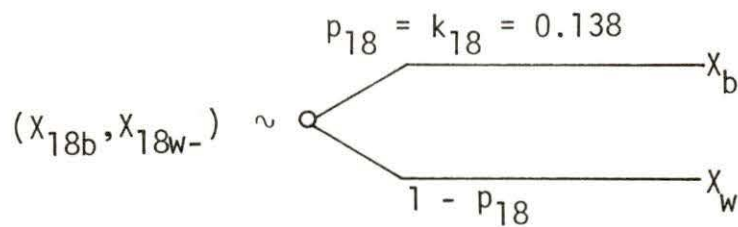
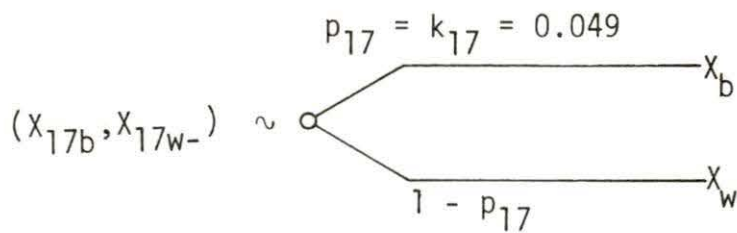
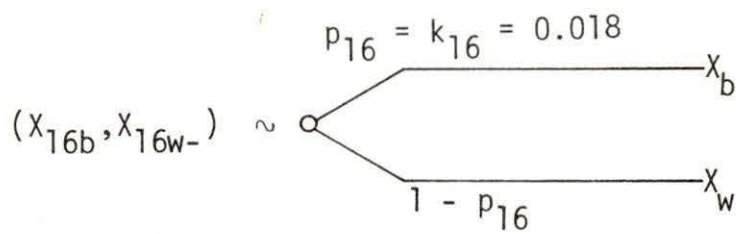
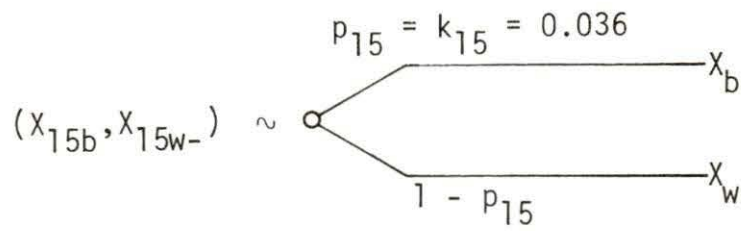
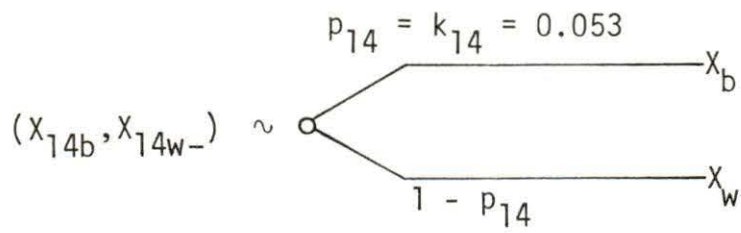

Figure 4.24 (Continued)

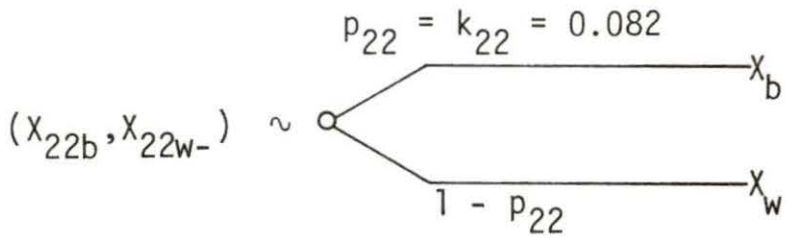
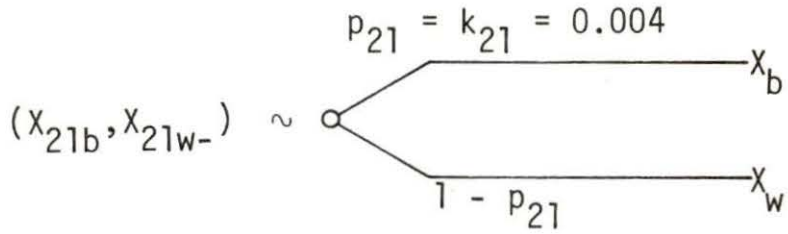
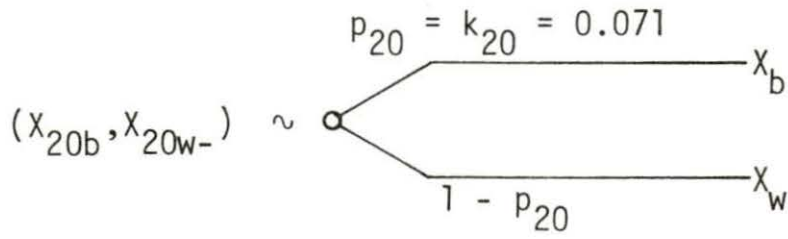
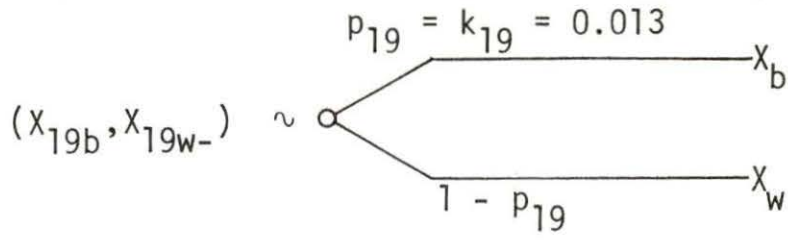

Figure 4.24 (Continued)

Table 4.3. The meaning of the symbols used for scaling factor lotteries

Symbol	Meaning
$X_{ib}$	Best level for ith attribute
$X_{iw}$	Worst level for ith attribute
$X_{iw}^-$	The attributes at their worst level except ith attribute
$K_i$	Scaling factor for the ith attribute
$P_i$	Probability of getting all attributes at there best level

#### 4.3.2. Utility scaling, K

When all utilities are in their best level, all  $u_i$ 's and  $U$  must be equal to one. Then Equation 4.2 can be rewritten as:

$$1 + K = \prod_{i=1}^{22} (1 + Kk_i). \quad (4.9)$$

A computer program (Appendix B) is used to calculate the roots of Equation 4.9 to get an appropriate value of the parameter  $K$ , by iteration process, this is

$$K = -0.578$$

Now, all terms in Equation 4.2 are known and hence it is possible to calculate the overall utility of a given specific strategy to implement any project for transfer of

nuclear technology to Saudi Arabia.

#### 4.4. Evaluation of Alternatives

Availability of information on alternatives, is a prerequisite for obtaining technology on the best possible terms and conditions. There is a genuine belief that excessive dependence on foreign technology is responsible for many aspects of underdevelopment. Often dependence on developed countries reinforces the social and economic status quo and in turn leads to further dependence (24). If indigent nuclear technology is to be developed, and if technological dependence is to be reduced, it is essential for Saudi Arabia, as a developing country, to spend concentrated efforts to build up domestic technological capabilities.

Three alternate options for transferring nuclear technology to Saudi Arabia may be chosen. Other alternatives are also possible however, the choice made here is consistent with the objectives and strategy recommended in Chapter 3.

The three alternatives for the proposed strategy for transfer of nuclear technology are

1. importing the technology,
2. importing with local participation, in construction,  
or
3. adapting the technology.

The attribute levels as the degree to which a particular alternative contributes in evaluating the overall utility function of that option is given in Table 4.4.

To calculate the overall utilities, Equation 4.2 may be rewritten as

$$U = [ \prod_{i=1}^{22} (1+Kk_i u_i) - 1 ] / K.$$

A computer program, given in Appendix B, is used to calculate the utility of each of the alternatives. The overall utility values for each of the alternate strategies are given in Table 4.5.

It is clear from Table 4.5 that adapting technology is the most desirable transfer system since it corresponds to the highest utility. Adapting technology has higher utility than local participating, and the last is higher than the utility of importing technology (25).



Table 4.4. Attribute levels for alternative systems

Attribute	Alternatives		
	Importing	Local Participating	Adapting
X <sub>1</sub>	10	13	17
X <sub>2</sub>	15	180	150
X <sub>3</sub>	70	100	80
X <sub>4</sub>	10	70	90
X <sub>5</sub>	5	85	70
X <sub>6</sub>	100	300	400
X <sub>7</sub>	90	30	70
X <sub>8</sub>	40	85	90
X <sub>9</sub>	.90	.65	.60
X <sub>10</sub>	40	90	85
X <sub>11</sub>	80	50	60
X <sub>12</sub>	.90	.70	.85
X <sub>13</sub>	80	65	95
X <sub>14</sub>	85	70	80
X <sub>15</sub>	50	90	65
X <sub>16</sub>	20	80	90
X <sub>17</sub>	85	95	90
X <sub>18</sub>	100	15	25
X <sub>19</sub>	0	3	8
X <sub>20</sub>	10	50	80
X <sub>21</sub>	5	60	90
X <sub>22</sub>	40	30	10

Table 4.5. Utility values of the alternatives

	Alternative	Utility Value
I	Importing	0.61906
II	Local participation	0.70009
III	Adapting	0.71335

## 5. MODELING OF VARIOUS MODES AND PHASES OF TECHNOLOGY TRANSFER

### 5.1. Domain of Transfer

The transfer processes of a given technology may be generally classified into three distinct types according to the domain of transfer.

The first kind involves transfer to and from different economic and cultural units of entities. Presumably, a country can be considered as a separate entity. This type includes transfer of technology between developed, developing and underdeveloped countries with the objective of improving, expanding, maintaining or initiating the industrial sector of the economy. Within the industrial arena, there is a continuous transfer process between various and possibly indigenous technologies.

This second type has a major impact on the development of the technology under consideration. This type of transfer processes also encompasses the impact of earlier technologies and practices on the evolution of the technology of interest.

The third kind, is the transfer of technology from concepts to a product for utilization. Both of the last two kinds of transfer need to be encouraged within the developing country to implement the thrust of transfer from developed countries thus covering the whole domain of technology transfer modes.

A transfer process may be generally represented by a simple chain formed from a source and a recipient connected by channels as the transfer media, Figure 5.1. The rate of transfer depends on the state of the source and the recipient and the phase of transfer which is determined by the type of channels used in the process (Table 5.1).

## 5.2. Available Models

Due to the diverse nature of the technology transfer process and the multitude of operations encompassed by the process, the models developed thus far are limited to one type or another of transfer. Often the models are devised to analyze a specific phase or state of a particular process. Some of the models are still in the embryonic stage and have not been employed in comprehensive analysis. Nevertheless, many of the models developed in human factor engineering and cybernetics can be applied to the study of transfer of technology. Transfer processes include phases such as learning, cognition, perception, communication, man-machine interface, information, flow, acquisition and retrieval, data handling and management, and adaptation.

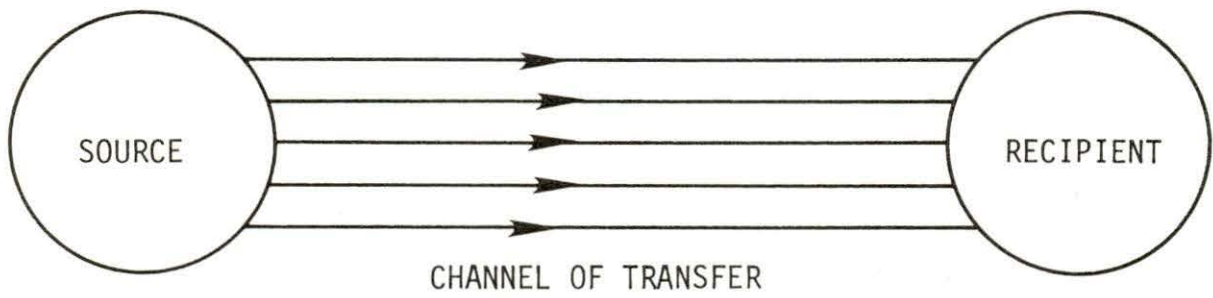

Figure 5.1. Simple transfer of technology model



Table 5.1. Types and components of transfer of technology processes

Type of transfer	Source	Channels		Recipient	
		Phase	Type	Type	State
1. Between countries	Developed	Import aid	Customers	Under-developed	Static consumption
		Adoption import	Diffusion information training	Developing	Static consumption
		Adoption	Training translation information innovative diffusion	Developing	Dynamic productive consumption
	Developing	Adoption	Import exchange	Under-developed	Static consumption
		Adoption	Import innovation	Developed	Static or dynamic
		Imitation coordination	Exchange competition	Developing	Static or dynamic
2. Between technologies	Contemporary proven technology	Development	Information techniques	Specific technology	Dynamic
		Imitation	Information	Specific technology	Static
	Early technology	Improvement	Evolution	Related technology	Dynamic
		Adaption	Techniques	Other technologies	Dynamic
3. From technology to use	Concept	Realization	Innovation customers	Use	Dynamic

### 5.3. Topological Models

#### 5.3.1. Temporal model

To facilitate the development of a systems analysis for the process of technology transfer it is necessary to develop a model which can be used to examine the relationship among the major channels of activity. A model such as that illustrated in Figure 5.2 may be used to provide a temporal topological view of the relationship between three sectors: science, technology and the ultimate uses of sciences and technology (26). Various possible loci of transfer and sources of idea generation can be depicted through time. Transfer may occur between the three stream flows, for example from technology to use. Transfer may also occur within a channel, for example nuclear reactors are used to generate electricity and then to produce desalted water.

The topological model does not accommodate for human factors, such as the quality of communication between engineers in the technology channel and scientists in the science channel, the gap between invention and innovation, or the role of the adopter or the potential recipient of innovation in facilitating or blocking the transfer process from one stage to another. However, if the schema is used to represent the interrelationships among science, technology, and industry existing in a given country, the degree

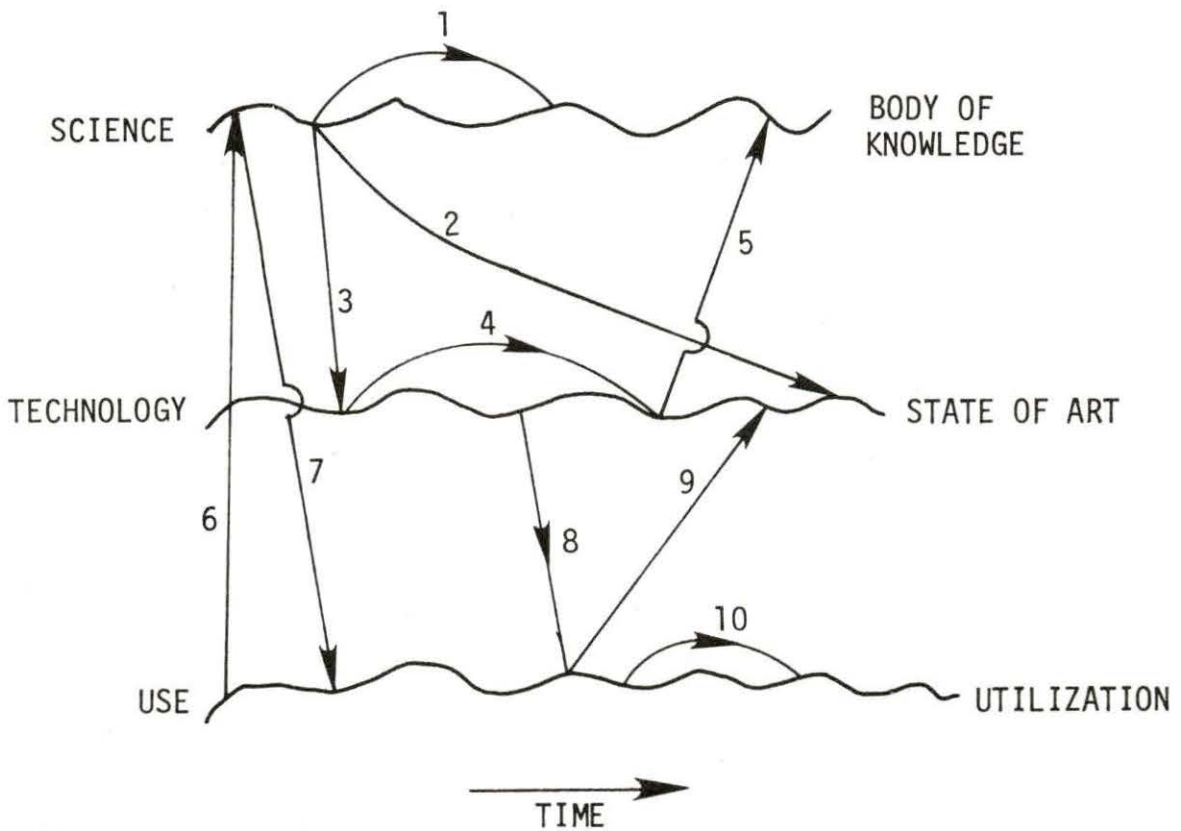
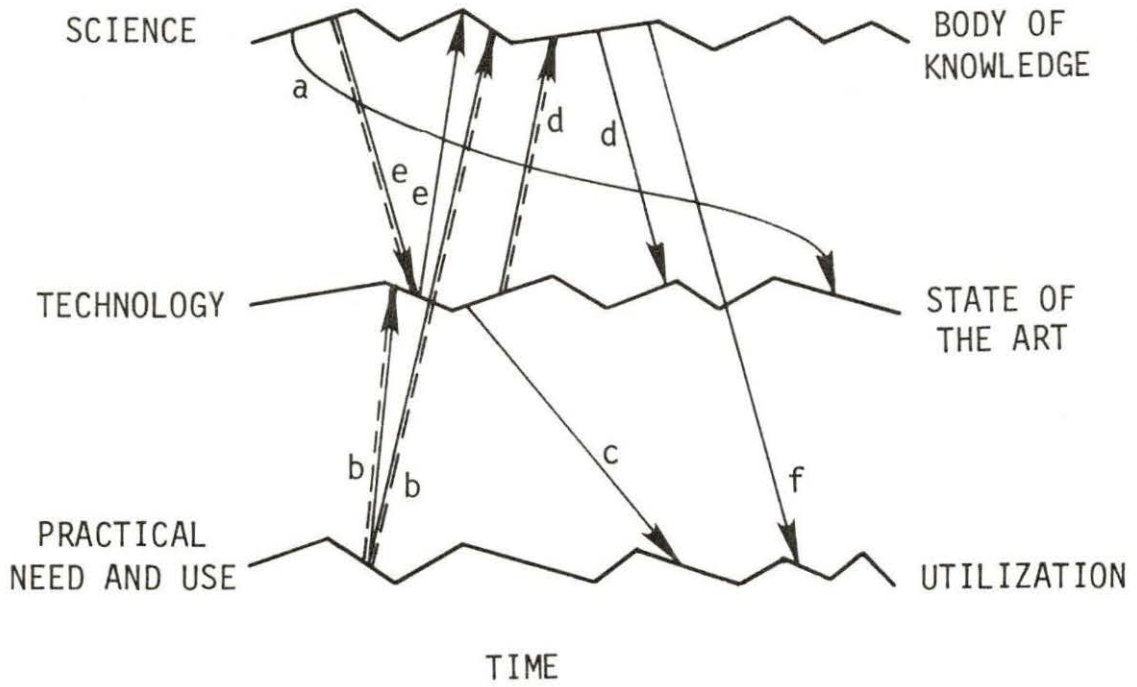

Figure 5.2. Topology of science-technology-use streams and communication paths ((1) science to science, (2) science to technology (slow), (3) science to technology (fast), (4) technology to technology, (5) technology to science, (6) use to science, (7) science to use, (8) technology to use, (9) use to technology, and (10) use to use (26))

of coupling occurring among these three sectors can be reflected in the average steepness of the crosslinks between them (27) as shown in Figure 5.3. Shorter crosslink gradients correspond to shorter time delays of response that is an increasing effectiveness of the interactions. Nevertheless, the gradients only represent overall or average response delays and only reflect gross behavior of the pools of available relevant variants that affect the solution of the problems in each sector. Such variants may be used to describe the internal process of evolution within the sectors.

#### 5.3.2. Internal processes

A possible complimentary graphic schema which may be applied to the internal processes of development within each sector is shown in Figure 5.4. Figure 5.4(a) represents the evolution of a particular area of science. The development of current ideas resulted from the selective perpetuation of specific theoretical or experimental variants which were instrumental in solving problems outstanding at earlier times. Pure intellectual judgement is used in this case to select the variants or the novel solutions of the scientific problem. The evolution of particular technology may be represented by Figure 5.4(b). Technical standards are used here to select the variants which are



RECOGNIZED NEEDS  
TRANSFER

Figure 5.3. Interrelationships among science, technology, and industry (27)



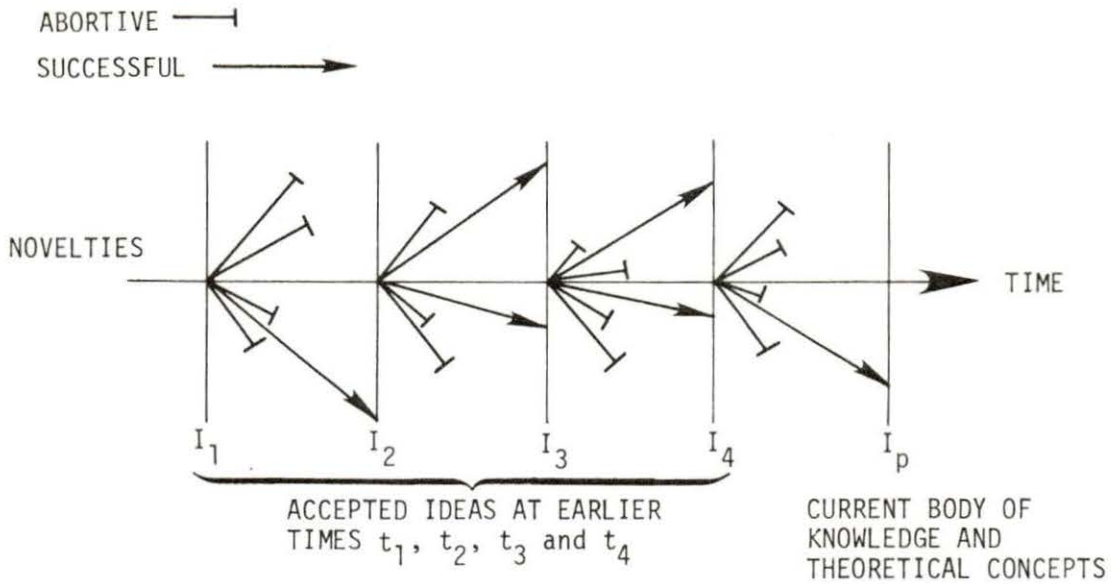

Figure 5.4(a). Evaluation of a particular area of science (27)

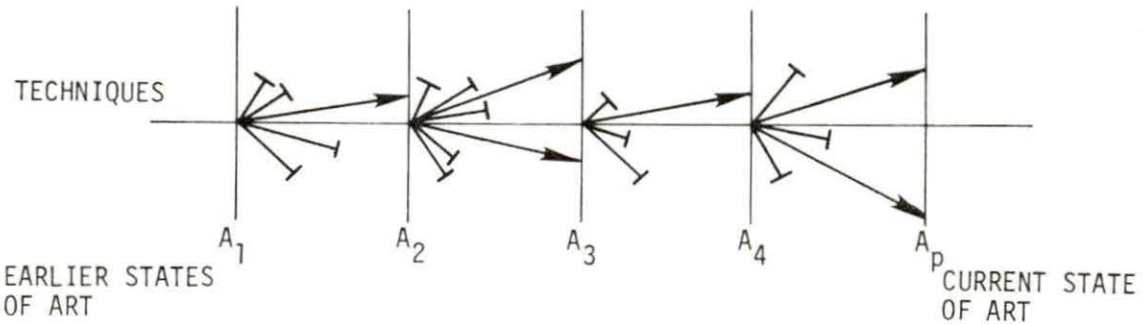

Figure 5.4(b). Evaluation of a particular technology (27)

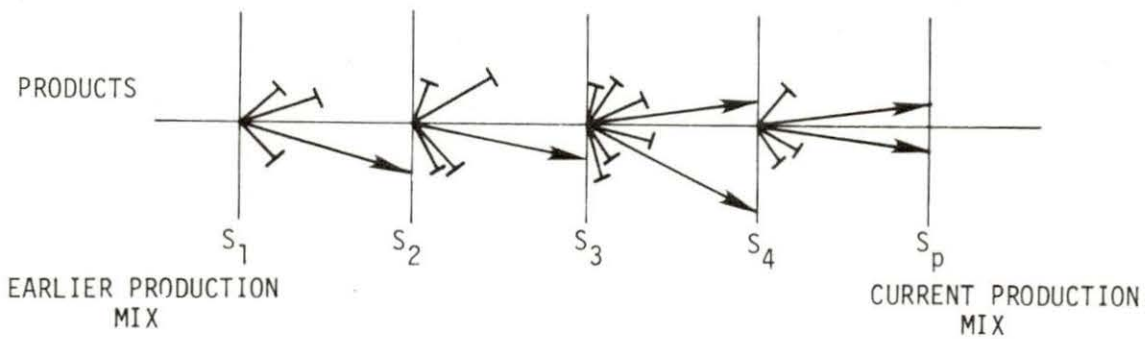

Figure 5.4(c). Evaluation of a specific productivity industry (27)

the suggested new solutions to outstanding technological problems. The main variable is the body of techniques or practical knowledge and the end-product is the temporal state-of-the-art. Similarly, Figure 5.4(c) is the illustration of the use sector or the evolution of a specific productive industry. Market standards contribute to the selection of the new products which are the variants for the solution of the product sector. The end-product is the latest pattern of the product in question. In the three cases, the variant can be either abortive or successful (27).

As an example, instances of successful and abortive transfer of technology are given in Table 5.2 in terms of the parameters of the topology model. The market was the basis for the success of power reactors and was detrimental in deciding the fate of nuclear aircrafts. Fear of aircraft accidents and of the consequences on radioactive release from the power reactor has reduced the potential marketability of the product. This is while the military use of nuclear-power satellites have enhanced the market of such product. The fate of fusion is unknown and its success depends on innovative efforts and marketability (28).

Table 5.2. Successful and unsuccessful transfer of technology in terms of the topology model

Variables in topology model	Successful	Unsuccessful	Fate Unknown
Science	Atomic and nuclear physics		Plasma physics
Technology	Critical assembly		Superconductors, vacuum pumps, accelerators, etc.
Use	Nuclear power plants	Nuclear aircrafts	Fusion power plants
Cause of present fate	Need for energy sources	Integrity during aircraft accidents	Thermonuclear plasma cannot be confined

### 5.3.3. Stationary model

A stationary topological model has been developed by Sabri and Amherd (28) to allow for greater insight in the nature of interactions between different sectors or domains. Thus, a graph needs to be remapped for each time period. The model has been applied to examine the transfer of technology processes leading to the use of fusion systems in commercial electricity generation. The model application to this situation is illustrated in Figures 5.5 through 5.7 to respectively represent communication paths among plasma physics, fusion technology and fusion power plants; fusion and other fields; and between the various

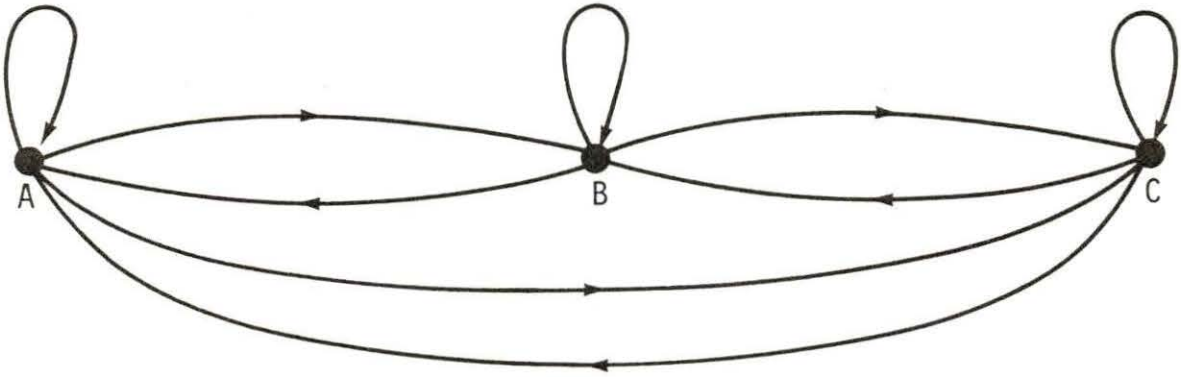

Figure 5.5. Model of interrelationships between the three domains: (A) plasma physics and related sciences, (B) fusion technology and (C) fusion power plant utilization (28)

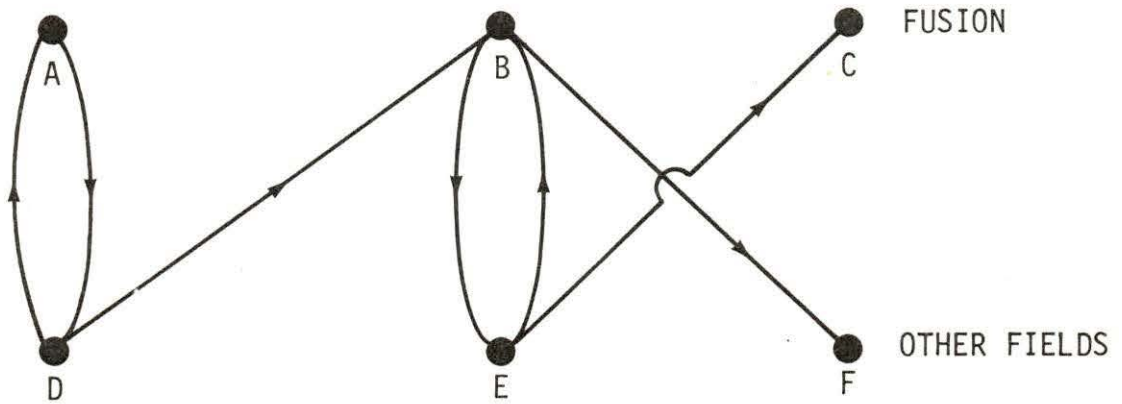

Figure 5.6. Important communication paths between fusion and other fields: A, B and C are as in Figure 5.5, (D) science, (E) technology and (F) utilization (28)



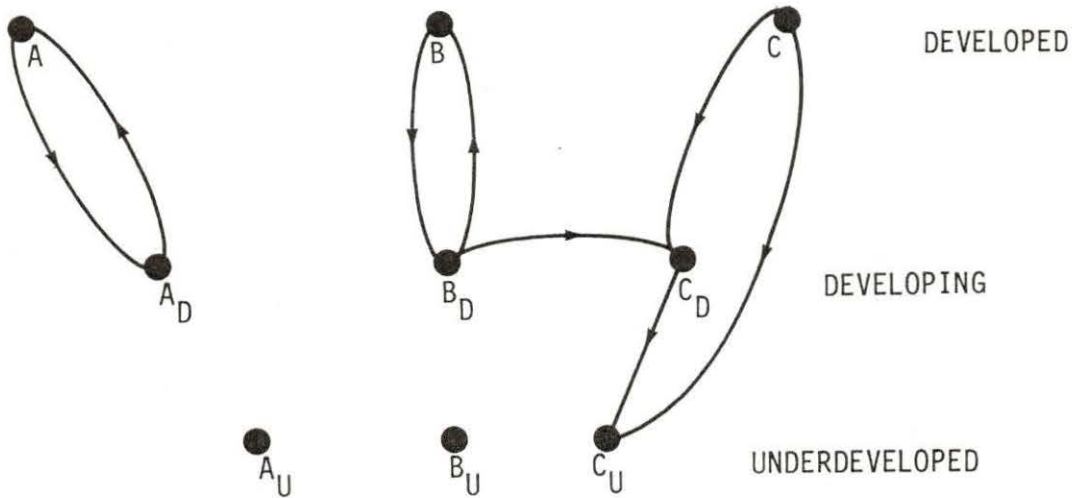

Figure 5.7. Important communication paths between developed, developing and underdeveloped countries in plasma physics (A), fusion technology (B) and power plant use (C). Subscripts D and U refer to developing and underdeveloped countries, respectively (28)

countries involved in the development and use of fusion energy and plasma physics.

#### 5.4. Probabilistic Models

##### 5.4.1. Sequential probabilistic model

A sequential series of probabilities may be used to determine the likelihood of transformation of a given bit of technical information into a new product that would result in eventual diffusion (26). Given a particular use of existing technology or a potential recipient the model examines the sequence of events within the organization structure of the user or recipient. Thus, the model concentrates on the process within the given organization. The process starts with the event that someone has the idea to examine a new piece of information and ends at the point of market in the output of the inventive effort. Using the symbol  $p(x_i)$  to note the probability the event  $X(t)$  with an outcome  $x$  will occur at time  $t$ , the probability of technology transfer  $P_{TT}$  within a given time  $t$  is generally given by

$$P_{TT} = \prod_{i=1}^n p(x_i) \quad (5.1)$$

assuming the events  $X_i$ ,  $i = 1, 2, 3, \dots, n$ , are independent and none exclusive. The outcomes  $x_i$  of the event  $X_i$  may be defined as in Table 5.3 for the special case of tracking

Table 5.3. Events and associated probabilities leading to introduction of a new product in the market by a specific organization

Event number	Probability	Outcome
1	$P_1$	Idea
2	$P_2$	Research
3	$P_3$	Development
4	$P_4$	Production
5	$P_5$	Innovation
6	$P_6$	Diffusion
	$P_{TT}$	Transfer of technology

the transfer process in a given organization to assess the likelihood of introducing a new product in the market at a given time. The total number of events in this case is  $n=6$ .

Variations of Equation 5.1 may result for different situations and interdependence may complicate the form of the model.

The probabilistic model can be used in connection with the topology model for a specific goal to produce one useful item. In this case,

$$P_{TT} = p(S)p(S-T)p(T)p(T-U)p(U) \quad (5.2)$$

where the events S, T and U are the availability of relevant scientific information, the discovery of a relevant technique and the presence of a market respectively and S-T and T-U are the events of having available links between science and technology and technology and use respectively.

#### 5.4.2. Flow block diagrams

Alternate representations of the flow of transfer of technology processes can prove to be useful in the case of probabilistic approaches to assess the success of the process. Probabilistic models include: event trees, process trees, cause-effect matrices, switching and flow block diagrams. These models can be analyzed in a straightforward way even in cases involving many interconnected events. One such method is the flow block diagram.

The sequential probabilistic model of Section 5.4.1 can be represented in the form shown in Figure 5.8. The overall probability of success for a series block diagram is the product of the probabilities of success of all components. A series flow block diagram is a sequential chain the breakage of an element in the chain results in failure of the whole chain. However, in practice alternate routes may appear viable during the process of transfer. As an example, let us consider production of nuclear power. A flow block diagram model may be applied to the following

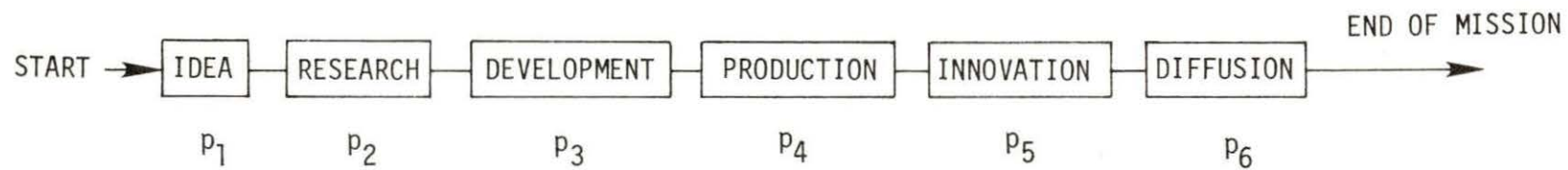

Figure 5.8. Flow block diagram for sequential probabilistic model



scenario: "a theoretical physicist came up with the idea to use exothermal nuclear reactions in producing power." The objective of the potential recipient is to build a commercial nuclear power plant based on any of the concepts evolved from the initial idea. The flow block diagram is illustrated in Figure 5.9. However, the presentation is not exclusive. The probability algebra is illustrated in Figure 5.10. Any flow block diagram is usually a combination of series and parallel diagrams. From the diagram of Figure 5.9 the probability of producing a power system can be obtained.

#### 5.4.3. Logic tree model

The logic tree may be used to represent the flow of the transfer process and to calculate the probability of success or failure of a given process. The elements of the tree are illustrated in Figure 5.11. A simplified model of the transfer of nuclear technology to a developing country is given in Figure 5.12. The probability of the output of an AND gate is similar to series block diagrams. The OR gate is similar to parallel diagrams. Several computer codes have been developed to carry logic tree analysis.

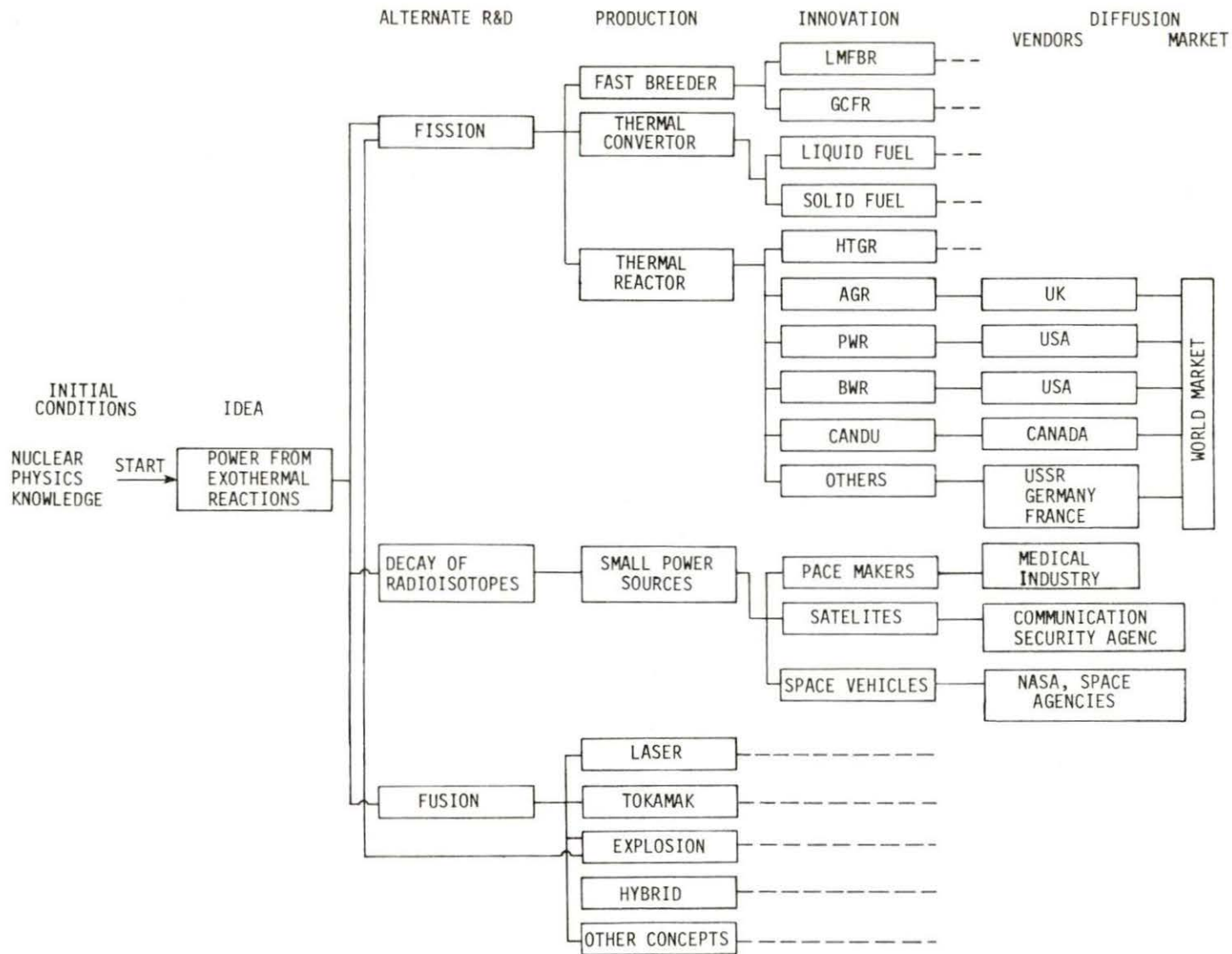
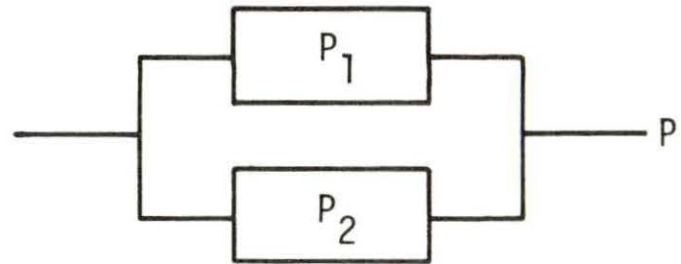

Figure 5.9. Flow block diagram of transfer of nuclear technology from concepts to power market



(a) SERIES

$$P = P_1 P_2$$



(b) PARALLEL

$$P = (1 - P_1)(1 - P_2)$$

Figure 5.10. Probabilities for series and parallel flow block diagrams

GATES

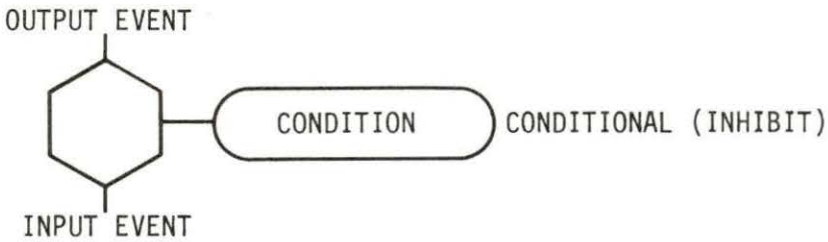
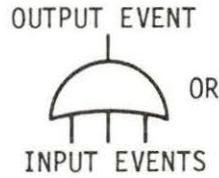
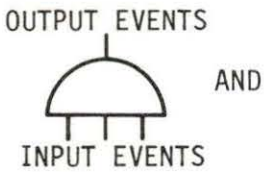

EVENTS

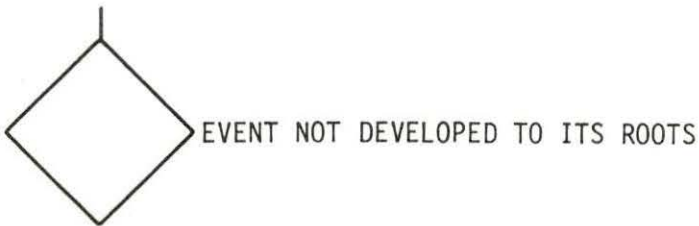
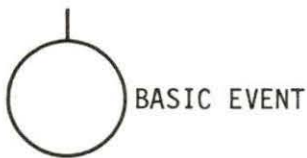
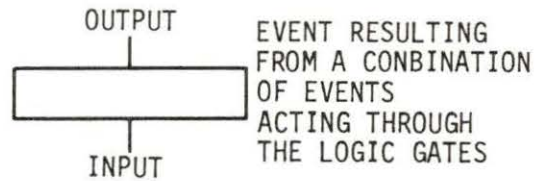
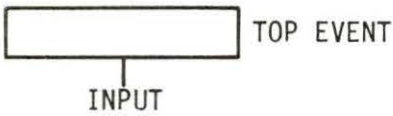

Figure 5.11. Symbols for logic tree model

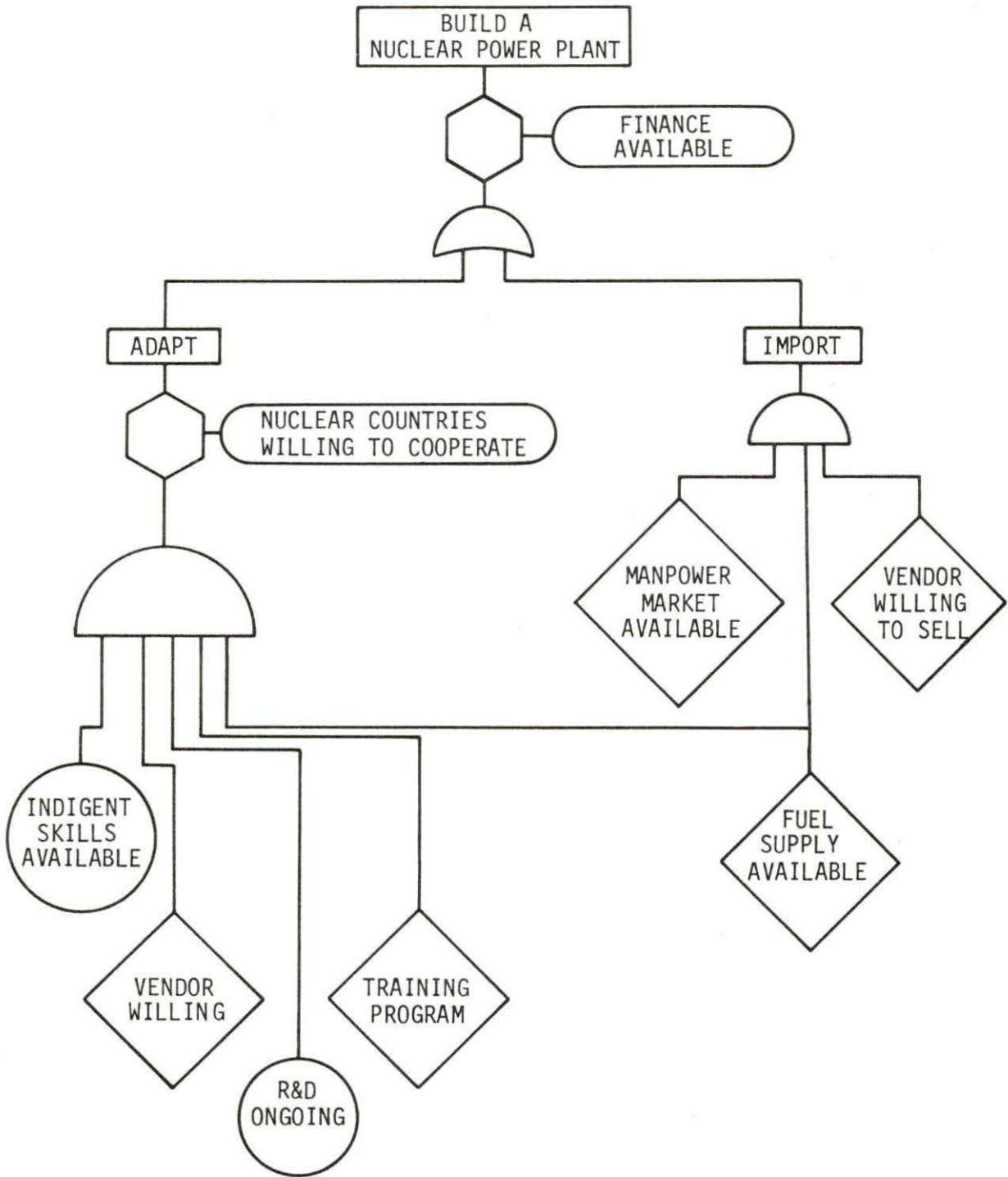

Figure 5.12. Logic tree for transfer of nuclear technology to developing countries



#### 5.4.4. Flow process tree

The flow in the process tree is downward starting from the initial event to the results. The example given in Section 5.4.3 may be represented by the flow process tree as in Figure 5.13 for the case of Saudi Arabia. The inhibit gates are decision points. Probabilities may be assigned to the branches to evaluate probability of success. The tree is also useful in identification of the flow routes of transfer processes.

#### 5.4.5. Event or decision tree model

The event tree is somewhat similar to the flow process tree. Often it is simpler to draw a flow block diagram prior to the construction of the tree. Figure 5.14 illustrates an example of the analysis of the probability of success of transfer of nuclear technology. The tree flows from left to right. The probabilities assigned to the upper branch are those of success of the events labelling the decision forks. The overall probability of success is the sum of the probabilities of reaching the nodes on the success bar, that is  $p_A$ ,  $p_B$  and  $p_C$ . Those are obtained by the product of the probabilities leading to the node of interest; that is

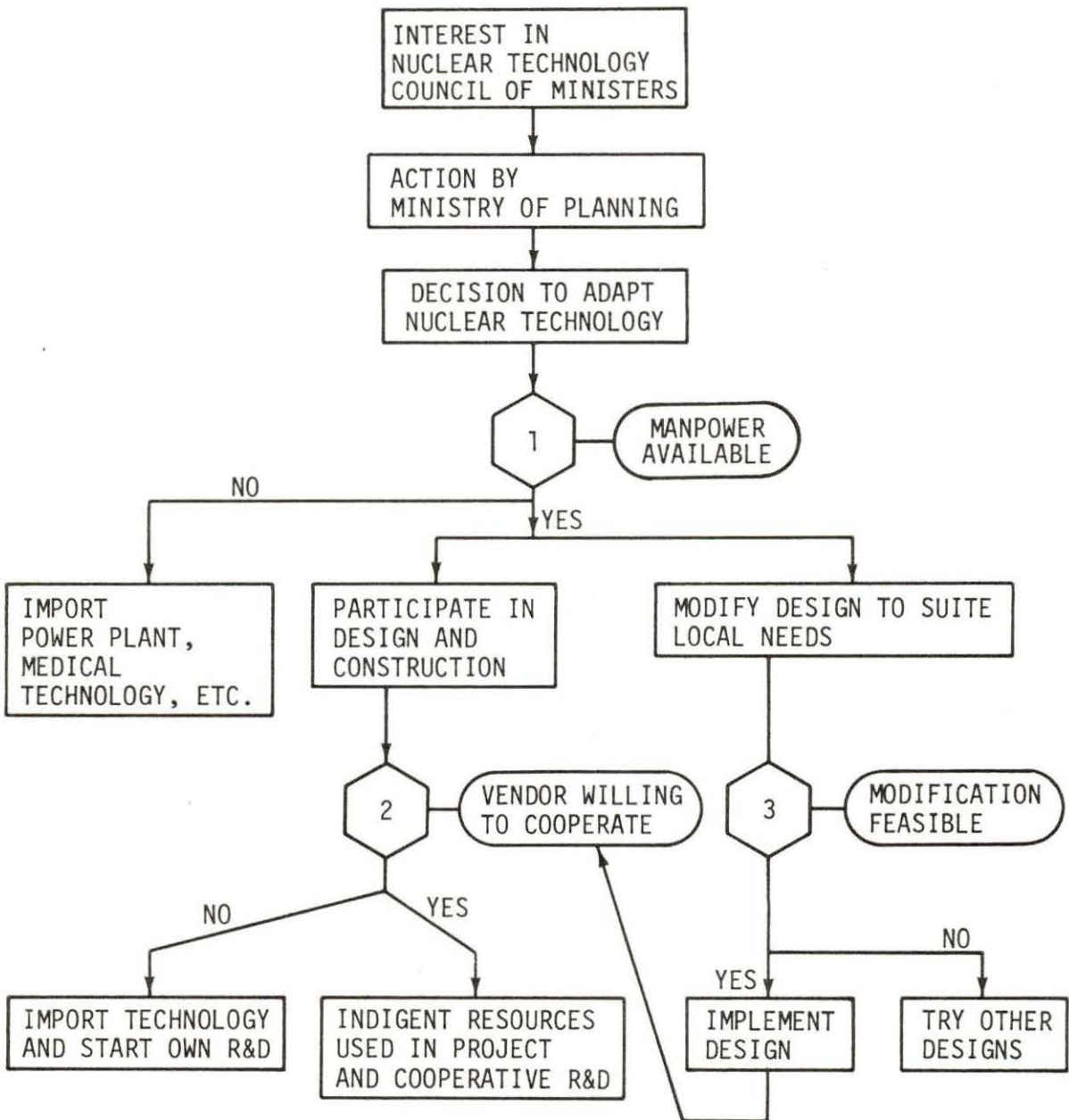

Figure 5.13. Flow process tree model of transfer of nuclear technology to Saudi Arabia

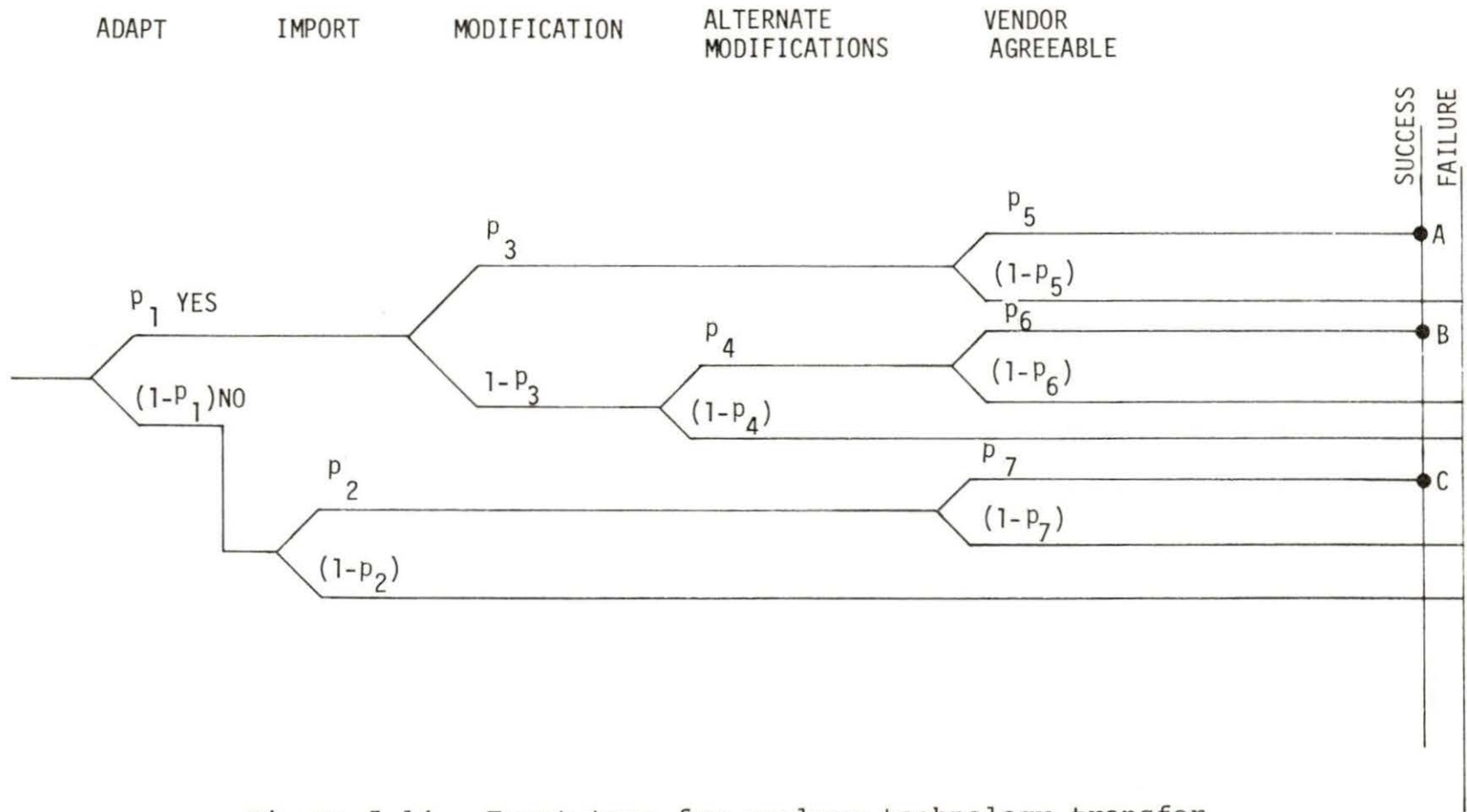

Figure 5.14. Event tree for nuclear technology transfer

$$p_A = p_1 p_3 p_5 \quad (5.3)$$

$$p_B = p_1 (1-p_3) p_4 p_6 \quad (5.4)$$

$$p_C = (1-p_1) p_2 p_7 . \quad (5.5)$$

Thus, the probability of success,  $P_{TT}$  is

$$P_{TT} = p_A + p_B + p_C . \quad (5.6)$$

The probability evaluation can be carried out by special computer programs.

#### 5.4.6. Cause-effect matrix

The cause-effect matrix can be used in conjunction with logic trees to assess the inherent feedback loops between events and to reduce the computation time in complex analysis. Figure 5.15 illustrates for an example wherein the inter-effects between five channels of transfer are considered. The matrix is generally  $N \times N$  matrix. The points are used to indicate the direct coupling between a cause  $i$  and effect  $j$ . For example the cause 2 is common to the effects 1, 3 and 4.

By reordering the matrix into the diagonal form given in Figure 5.16 more insight can be found in the analysis and review of the process development. For example, a feedback loop exhibits the fact that training and R&D have a continuous effect on each other. A propagation path may

EFFECT	TRAINING 1	TRANSLATION AND INFORMATION 2	R & D 3	PLANT CONSTRUCTION 4	IMPORT 5
TRAINING 1			•		
TRANSLATION AND INFORMATION 2	•		•	•	
R & D 3	•				
PLANT CONSTRUCTION 4	•		•		
IMPORT 5				•	

Figure 5.15. Cause-effect matrix



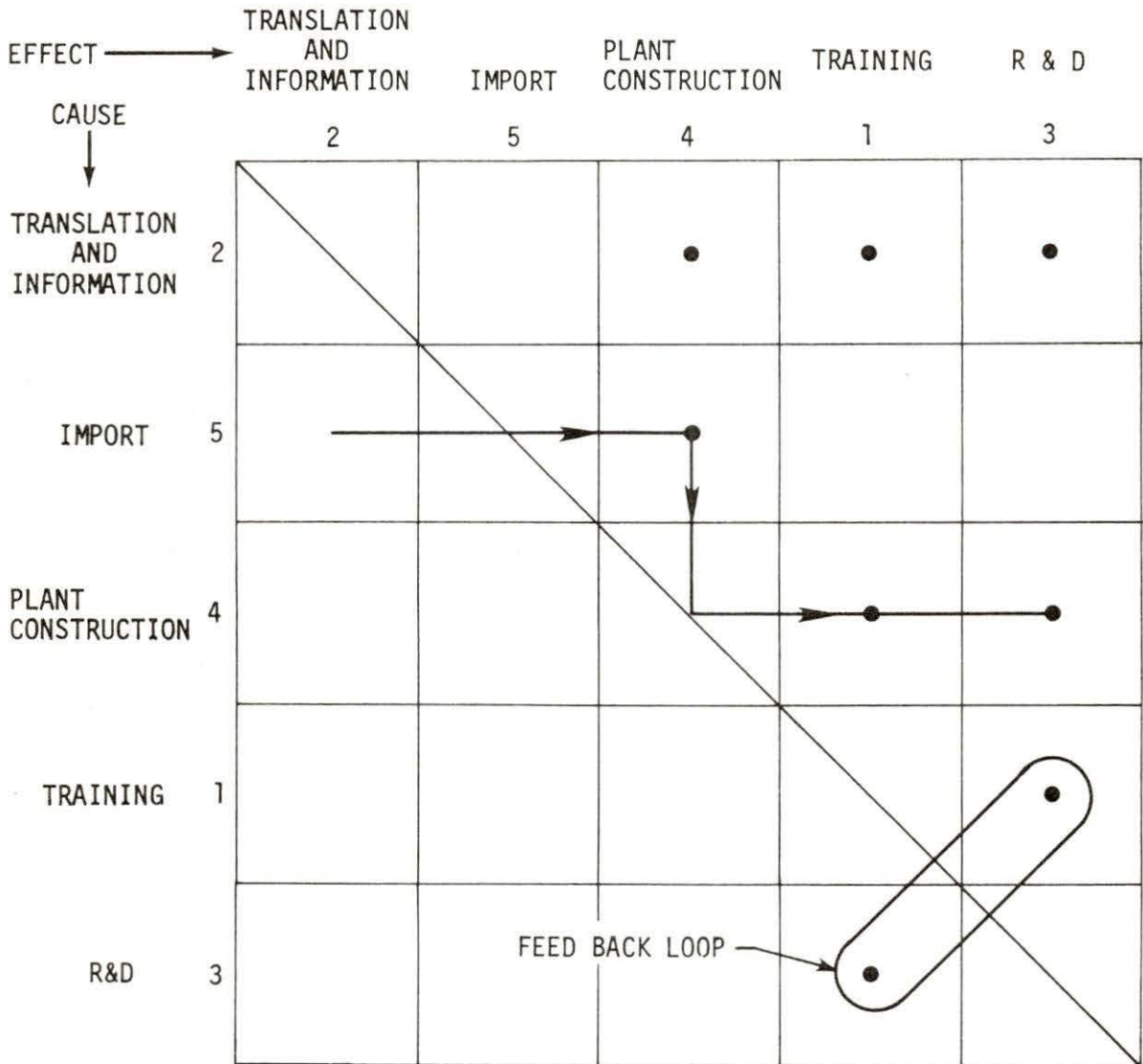

Figure 5.16. Reordered cause-effect matrix

restrictive the transfer of an idea into research, development etc. has a low probability. Also, the idea would be rejected if the potential recipient showed lack of interest during the sequential flow of transfer from idea to product. If the idea led to product, there would be a low probability that it would pass the critical test of diffusion or marketability. An example of the variables of the functional model are given in Table 5.4 for three sectors, the Ministry of Planning, the Ministry of Finance and the business arena. In this case, Equation 5.7 takes the more explicit form

$$M_T = f(\text{innovator, innovation, C, R}) . \quad (5.8)$$

In Table 5.4 improvement of the performance of client, public, or consumer refers to achievement orientation as a goal. In other words one of the important goals of innovation is to improve or aid the others. The Ministry of Planning, for example, attempts to improve the standard of living of the public while the businessman tries to do a better job.

#### 5.5.2. Flow diagrams

Although flow diagrams are useful in probabilistic analysis, they can also be used for functional evaluation of a certain aspect of transfer of technology. Flow diagrams are also useful in review of the various facets

Table 5.4. Variables of the functional transfer model in the planning, utility and business sectors in Saudi Arabia

Variables	Ministry of Planning	Ministry of Electricity	Business
1. Innovator-entrepreneur	Planner	Engineer	Businessman
2. Innovation			
2.1 Domain	Improvement of future conditions	Service improvements	Improvement of goods
2.2 Goal	Improvement in performance of the public	Improvement in performance of the clients	a. Pattern maintenance b. Improvement in performance of consumers
2.3 Quality control	a. Training and experience b. Public consensus c. Governmental consensus	a. Cost efficiency b. Continued supply c. Safety	a. Profitability b. Cost efficiency
3. Structure of channels for transfer	a. Universities and professional schools b. Information systems c. Technical training d. Translations e. R&D institutions	a. Training b. Information	Private corporation including innovation, production and marketing functions
4. Recipient	Public whose goal is improvement of performance	Clients whose goal is improved performance	Consumers whose goals are: a. Improved performance b. Pattern maintenance

of the flow chart of the transfer process. For example, considering possible relationships between three sets of companies within the immediate interest/relevance perimeter of a given technology, Figure 5.17 may be constructed. The diagram illustrates the impact of innovation in terms of producing a new and improved product for making an existing product (30). A modified model is shown in Figure 5.18 to account for the difference between acquisition and manufacturing.

The flow diagrams can be simple or complex depending on the element of the process under consideration. An example of a simple process is given in Figure 5.19 to model the technical activity (31). A possible feedback mechanism is incorporated in the model.

The time factor can be introduced in conjunction with the flow diagram model. Figure 5.20 shows a four-stage process of technical advance starting at a given time  $t=0$  and ending at time  $t=t_1$ . The cycle continues in the same direction in a similar fashion. The technical advance is defined here as an increase in the level of technical knowledge and/or increase in the economic uses of technical knowledge.

Two critical factors in technology transfer are the recognition of demands that have not been satisfied by current technology in use in the country and the recognition

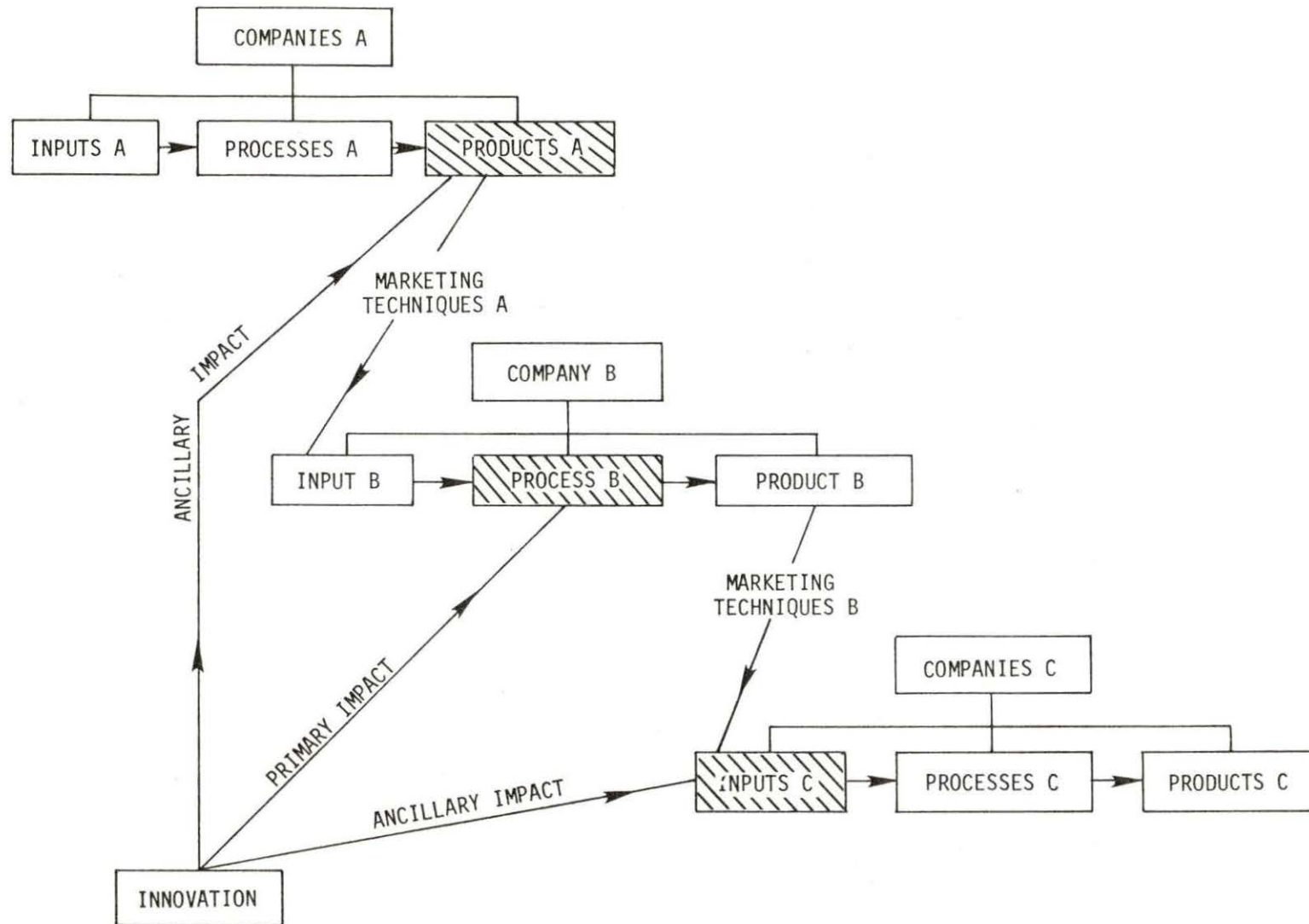

Figure 5.17. A model of the interest/relevance perimeter of the technology (30)



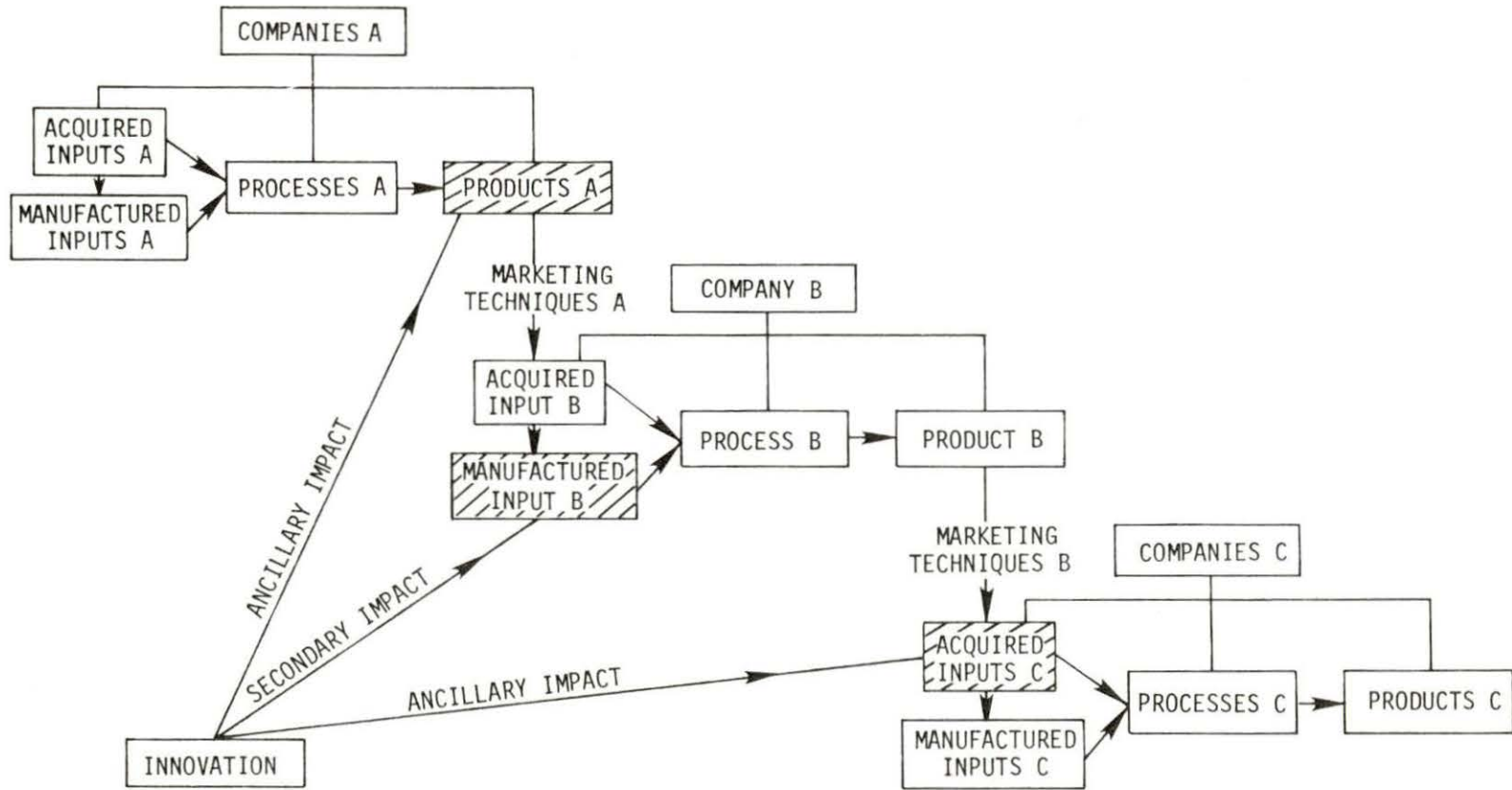

Figure 5.18. Modification of the company-technology relationship (30)

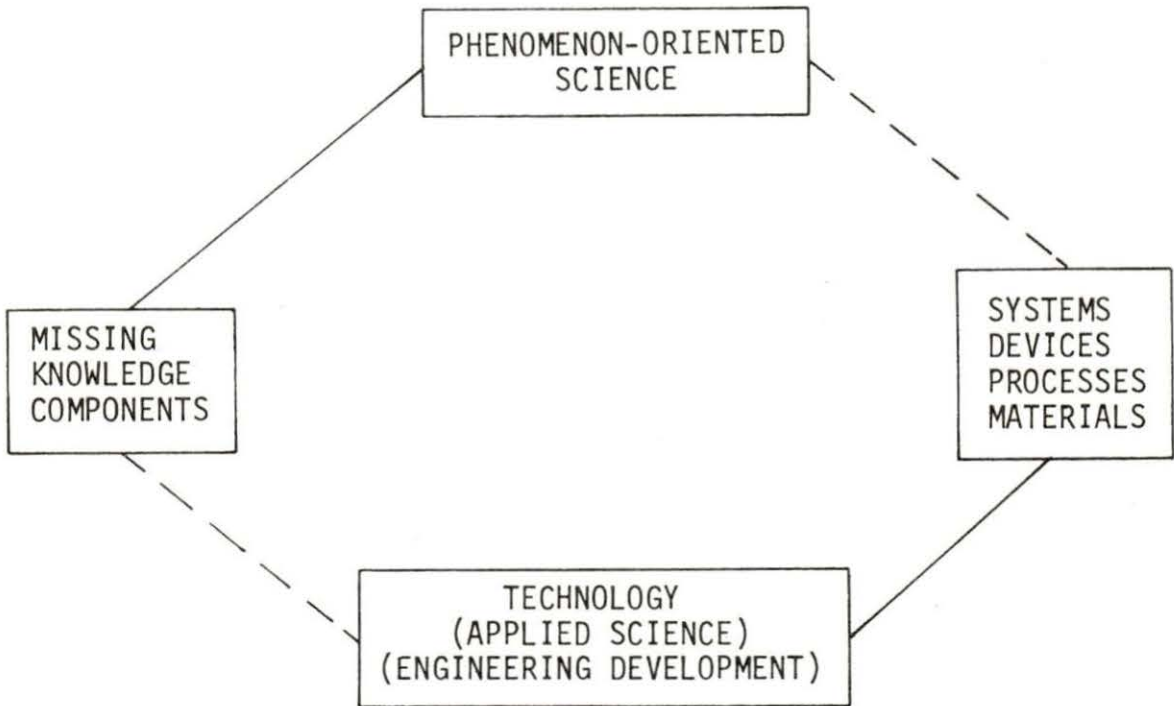

Figure 5.19. A model for technical activity

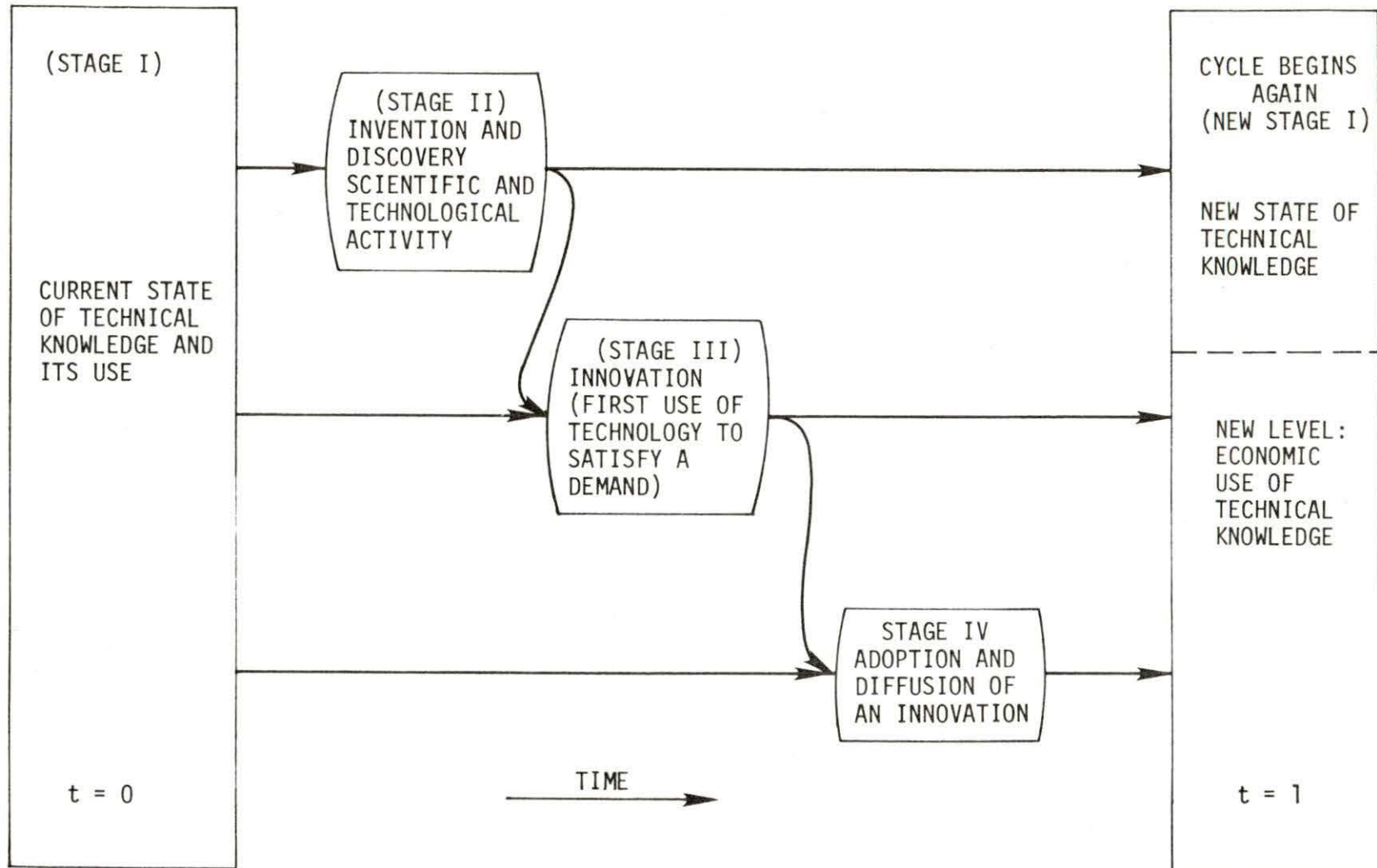

Figure 5.20. A four-stage process of technical advance (30)

of technical feasibility. Technical advance at a micro-level can take place by fusion of these two factors. Innovation is most likely to be initiated when such fusion takes place and a satisfactory technical response to a user requirement becomes available (32). Figure 5.21 illustrates such technical advance model.

## 5.6. Statistical Models

### 5.6.1. Diffusion model

Husseiny and Sabri proposed a model based on the statistical nature of the diffusion aspects of the transfer of technology (33). This model is briefly presented here.

The scatter of the data and information bits required for assessment of the transfer of nuclear technology problems and the complexity and diversified nature of those problems do not lend themselves to an overall objective qualitative analysis. In contrast, mathematical models are readily amenable for providing specific solutions in a wide spectrum of situations and constraints. Simulation, modeling and the embedded wealth of information may seem meaningless to the public and the administrator. Nevertheless, the results; if translated to common terms, have a great potential for improvement of procedures of technological change mutatis mutandis. In this paper, earlier

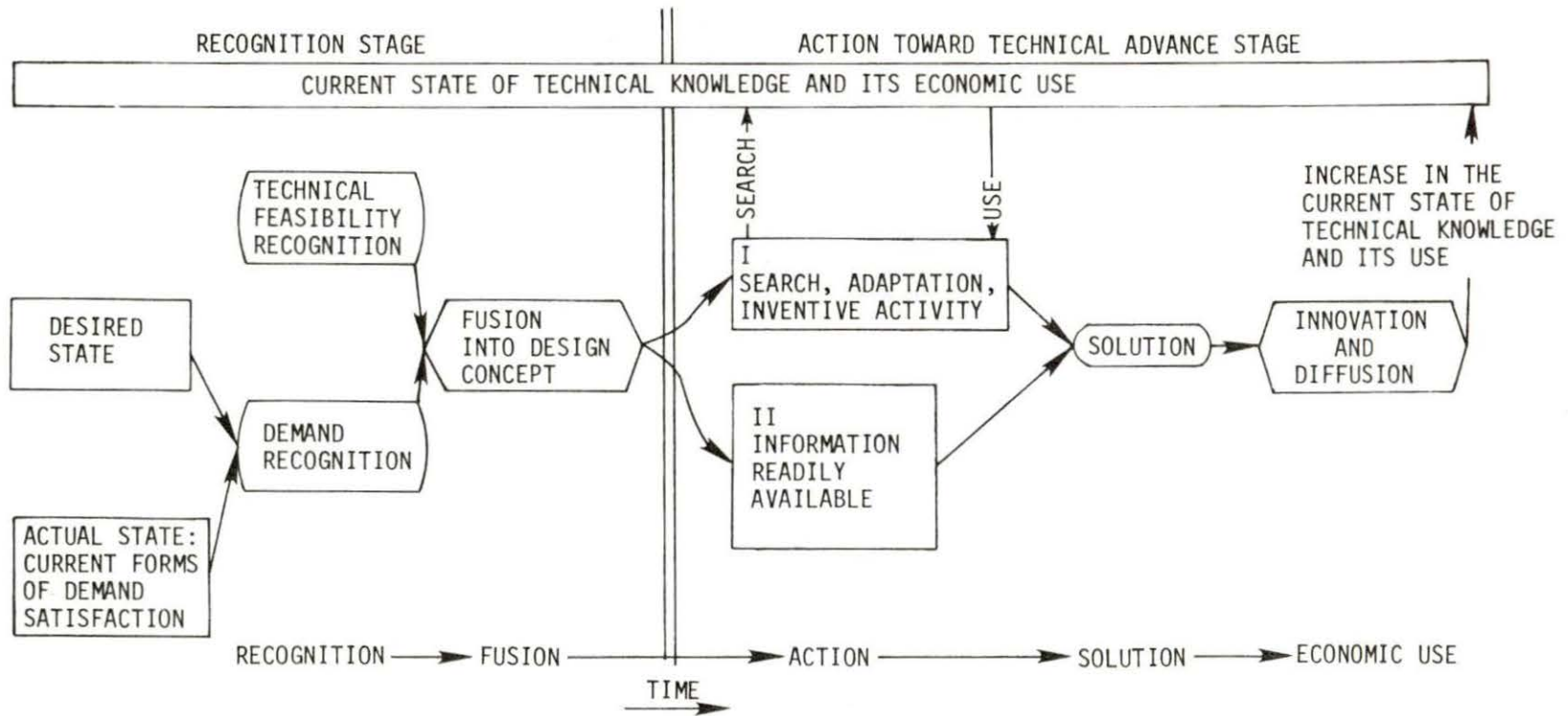

Figure 5.21. Technical advance (at a microlevel) related to demand-technical feasibility fusion (32)



attempts to develop models of general technology transfer are reviewed. Also a model is developed to provide a framework for analysis of problems of the transfer of nuclear technology with emphasis on the technology diffusion aspects. The parameters involved can be directly estimated from current statistical field data.

Socioeconomic aspects of technology transfer have been represented by mathematical models some of which were used in simulation studies that incorporate several economic and human factors (34). Mathematical treatment of growth, unemployment, behavior, policy control and other socioeconomic factors tends to be complicated since it deals with a large dynamic macrosystem (35-37) and it requires substantial data base. The simplest model involves four highly aggregate accounting and behavioral difference equations which allow for sensitivity analysis to determine the change of specific parameters under different constraints. Three preliminary models have also been synthesized to specifically describe the flow of technology transfer. One model provides a topological view of the temporal relationship between science, technology and their ultimate utilization. The second model examines the sequence of events within a given recipient organization structure using a probabilistic approach. The other model assigns a magnitude

to the transfer process expressed as a function of several parameters; such as the nature of technology to be transferred (26).

For most existing technologies; specially simple processes, transfer processes assume abrupt modes of change represented in time by a sequence of impulses. In contrast, the transfer of nuclear technology tends to occur as a smooth continuous diffusion in a temporally homogeneous manner due to its level of sophistication. In this case, the transfer rate is time-dependent and the transfer probability is a function of several statistically independent parameters. For simplicity, the process is assumed to be described by a single parameter,  $X(t)$  having an initial value  $x_0$  at  $t_0$  and a value  $x$  at time  $t$  within a region of acceptance  $(x_U, x_L)$ . Extension of the treatment to multi-parameter systems is straightforward. By statistical reasoning, it can be shown that  $X(t)$  is Markov (38) and hence future behavior can be predicted from present values regardless of past history. Also, the technology diffusion process is Brownian and hence it can be completely represented by a transitional probability density function,  $f(x, t | x_0)$  which is obtained as a unique solution of the Fokker-Planck equation,

$$\frac{\partial f(x, t | x_0)}{\partial t} = D \frac{\partial^2 f(x, t | x_0)}{\partial x^2} + 2C \frac{\partial f(x, t | x_0)}{\partial x} \quad (5.9)$$

where C and D are the drift and diffusion coefficients respectively. Physically it is conceivable to assume that the probability of technology diffusion diminishes for infinite values of x calculated from present values, thus using Laplace transform in x, Equation 5.9 can be integrated to give the first-order probability density function,  $f(x,t)$ , that is

$$f(x,t) = \frac{1}{\sqrt{2\pi} \sigma(t)} e^{-\frac{[x-\mu(t)]^2}{2\sigma^2(t)}} \quad (5.10)$$

where  $\mu(t)$  and  $\sigma^2(t)$  are the mean and variance. The probability that the technology diffusion process is of a magnitude within the region of acceptance may be obtained from the density function by integrating over the range  $(x_L, x_U)$  at a specified time. The result is given by the difference of two error functions,

$$p(t) = 1/2 \left\{ \operatorname{erf}\left(\frac{x_U - \mu(t)}{\sqrt{2} \sigma(t)}\right) - \operatorname{erf}\left(\frac{x_L - \mu(t)}{\sqrt{2} \sigma(t)}\right) \right\}. \quad (5.11)$$

The rate at which the transfer of nuclear technology takes place in a favorable dynamic system,  $r_f$  is

$$r_f = \frac{2C}{x_U - x_0} \times \begin{cases} \exp\{2C(x_U - x_0)/D\} & C < 0 \\ 1 & C > 0 \end{cases} \quad (5.12)$$

and in stagnant system the transfer rate,  $r_s$  is

$$r_s = \frac{2C}{x_0 - x_L} \times \begin{cases} 1 & C < 0 \\ \exp\{2C(x_0 - x_L)/D\} & C > 0 \end{cases} \quad (5.13)$$

where  $x_L < x_0 < x_U$ . The coefficients  $C$  and  $D$  can be determined from the values of  $\sigma(t)$  and  $\mu(t)$  at present and at an earlier time which can be obtained from actual field data, that is

$$C = \frac{\mu(t) - \mu(0)}{2t} \quad (5.14)$$

and

$$D = \frac{\sigma^2(t) - \sigma^2(0)}{2t} \quad (5.15)$$

The rate of diffusion of nuclear technology assumes a shape similar to that of the learning curve (39); however, the parameters involved can be determined with sufficient certainty using the method developed here.

#### 5.6.2. Cybernetic model

The trend in the man-machine interactions takes a typical pattern of behavior which represents a common phenomena that prevails in many situations. Sabri, Husseiny and Danofsky (40) have developed a model based on this observation to account for human response to various stimuli. The model can be used in the analysis of the overall transfer of technology process. The model can be



interpreted using the Schumpeter theory (15) and the Grossman learning curve (39). The model is shown in Figure 5.22. The curve is divided into four phases representing the evolution of transfer of technology in a given country. The transfer process ascends to a saturation plateau which continues until a static state is reached in which innovation is demolished and a decline takes over. The initial point represents the point of time at which a new program of technology transfer started.



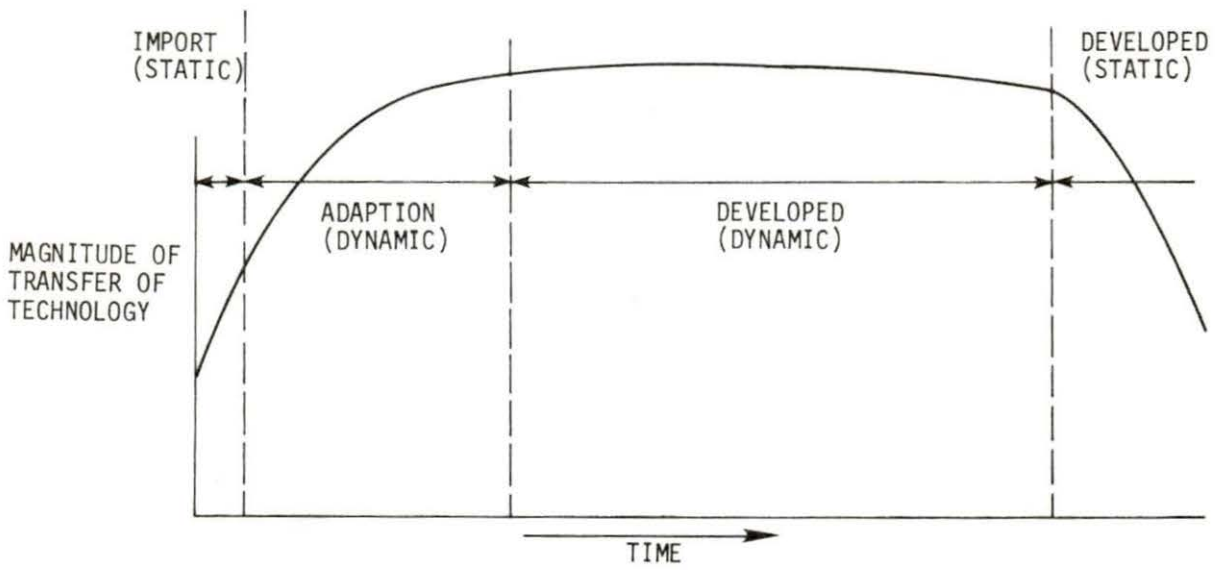

Figure 5.22. Cybernetic model

## 6. MONITORING OUTCOMES OF TRANSFER OF NUCLEAR TECHNOLOGY

### 6.1. Progress and Technical Advances

The transfer of nuclear technology processes involve the combination and the functional coordination of various elements towards an identified goal. The elements include human performance; various systems of information, organization, scientific and technical knowledge, and diffusion, and machines and equipment. The interaction between those elements of different properties and functions could be coordinated in a system network. Consequently, a system network analysis may be successfully employed to various aspects of modern technology transfer provided that a model is developed to encompass the objective and the parameters relevant to the analysis.

As being pointed out in Section 5.5.2 and illustrated in Figure 5.20, it is possible to have technical advance without economic use or without impact on the overall progress of the country. The interrelation between advance in technology and progress may be used as a measure to monitor the process of technology transfer.

## 6.2. Model

A pictorial presentation of the state of a recipient country R is given in Figure 6.1. The two-dimensional cartesian coordinates describe the state of the country at a given time which result from transfer of technology. X refers to advancement in the technology and corresponds to the x-axis. The variable X may be assigned units of man-million \$ since it can be measured by the spending of funds to produce efficacious manpower. The expenditure is assumed to be effectually allocated on R&D, training and other activities that result in advances of technology. The manpower includes all skills and innovators who, if effectively utilized can contribute to the technology advancement. The variable, Y in the y-direction reflects the progress in terms of economic achievement measured by the GNP in million \$ or by effectual spending on growth in production and construction of technology related projects measured by the skills utilized in the growth. Thus, man-million \$ may be used as a metric for progress. The vector  $\vec{r}$  refers to the direction of transition relative to the advance and progress frame of reference. The magnitude  $|\vec{r}|$  indicates the resultant achievement in terms of economic progress and technical advancement which transforms the state of the nation from a state A to A'. Arrows pointed

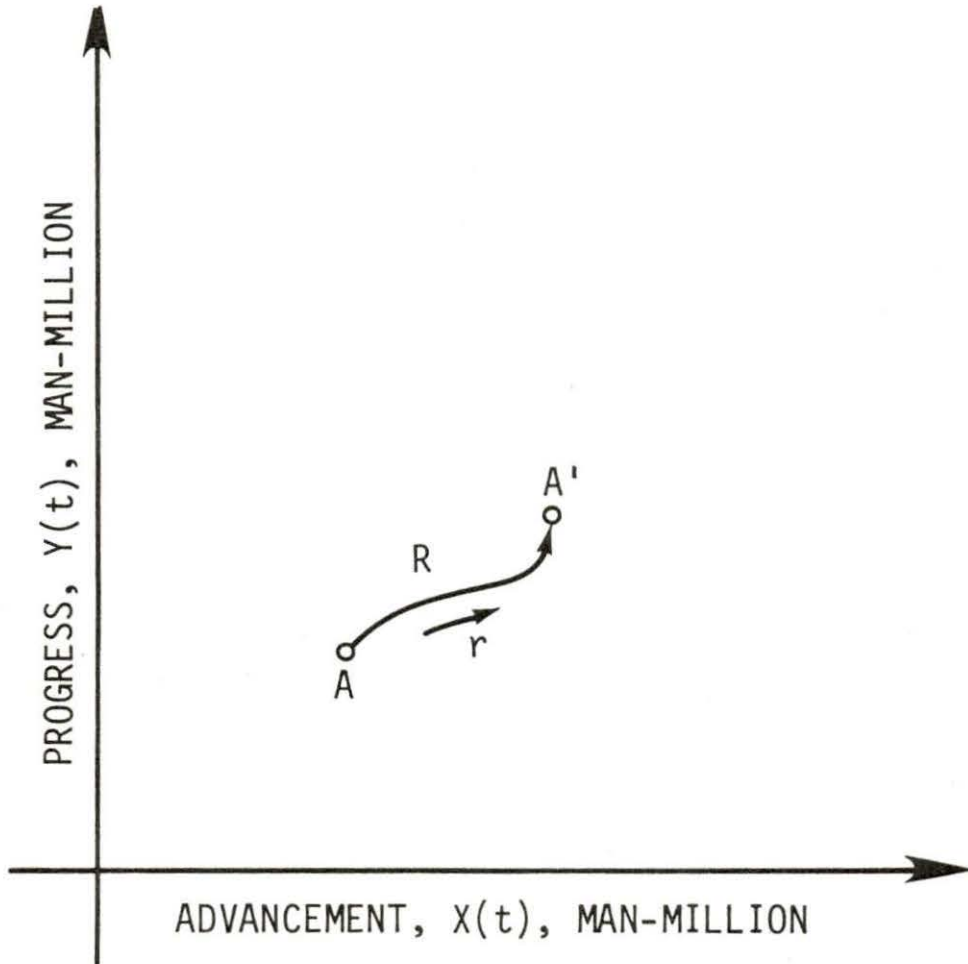

Figure 6.1. Progress-advancement model of a recipient, R

forward or upward refer to general progress while opposite orientation refers to regress in the overall state.

Since measure of progress and advancement is usually done on a relative scale, the state of the recipient country may be represented in a dipole with respect to a reference country, most appropriately the country which is likely to contribute most as a source for the transfer of nuclear technology, say the United States. However, the reference S may be taken as an average of the nuclear countries contributing to the nuclear technology. Although, the choice of a nonnuclear developing or underdeveloped country as a reference may provide a measure for competition with peers, the advantage of using a nuclear developed country as a reference is in identifying the relative goals of progress and advancement. Figure 6.2 represents the relative model where  $\vec{r}$  is the difference vector between the state A of country R and the state B of country S;  $\vec{r}_0$  is the closest approach distance identified by the relative position of an optimal state  $A_0$  of R relative to S(B); and the angle  $\theta(t)$  is the phase angle between the direction of the state of R and the advancement in technology vector. As the angle  $\theta$  gets smaller the transfer of technology process would result in more technical advance but with less impact on economic use. A large angle less than  $90^\circ$  indicates more progress. This is often possible, since a high rise in



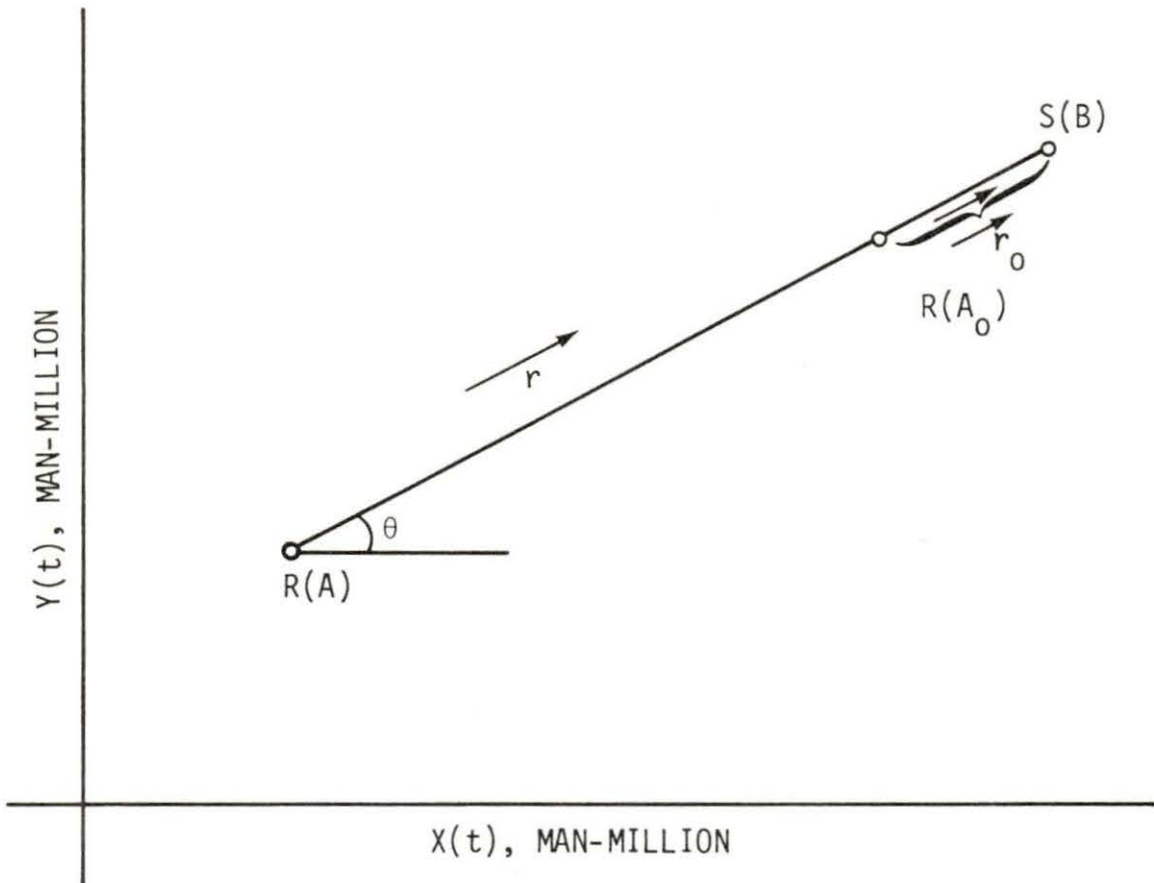

Figure 6.2. Progress-advancement model of a recipient R relative to a source, S

construction rate and/or GNP may be a result of increased export of oil, for example. A rise in progress is likely to be of a transit and temporary nature unless a matching increase in technical advancement. The phase angle  $\theta$  in development space may be used as a measure of efficiency of progress,  $\eta_p$ .

$$\eta_p = \sin \theta = Y/r. \quad (6.1)$$

However, to consider the relative importance of progress and technical advances a merit factor,  $I_p$  may be defined as

$$I_p = \tan \theta = \frac{Y}{X}. \quad (6.2)$$

A desirable merit figure would result if  $\theta$  is selected in an acceptable range of values,  $\theta_{\min} \leq \theta(t) \leq \theta_{\max}$  where the range excludes ranges below  $\theta_{\min}$  wherein irrelevant technical advances prevail and ranges above a  $\theta_{\max}$  in which technical advances are ignored. Also, the distance  $r$  should fall in the range  $r_0 \leq r(t) \leq r_1$  where  $r_1$  is the present distance between R and S. The developing country may aim at acquiring a state equal to that of the developed country B, a quasi-developed  $r_0$  may be instead achieved. The vector  $\vec{r}_0$  is determined by several considerations including:

1. difference in the objectives of the nuclear and the developing countries;
2. constraints imposed by nuclear countries on providing some information, technical know-how, or appropriate facilities to nonnuclear countries;
3. the existence of cultural and ideological barriers in the developing countries;
4. difference in the approach adapted by the developing country from that employed by the nuclear country;
5. the progress and/or technical advancement rates in the countries R and S may be greatly different; and
6. slow diffusion of the developing technologies as compared to the diffusion of the corresponding developed technologies.

The position and direction of  $\vec{r}_0$  may be changed depending on the relative states  $A_0$  and B. A developing country may progress or advance at high rates than the reference developed country, so that at some point of time in the future  $\vec{r}_0$  may be flipped to point to the opposite side.

Thus, the rate of technical advances and progress is of important to define the state of  $P(A(t))$  at some arbitrary time. The rates can be represented in the velocity space for each of R and S as shown in Figure 6.3, where  $v_{RY}$  and  $v_{SY}$  are the rates of progress of the de-

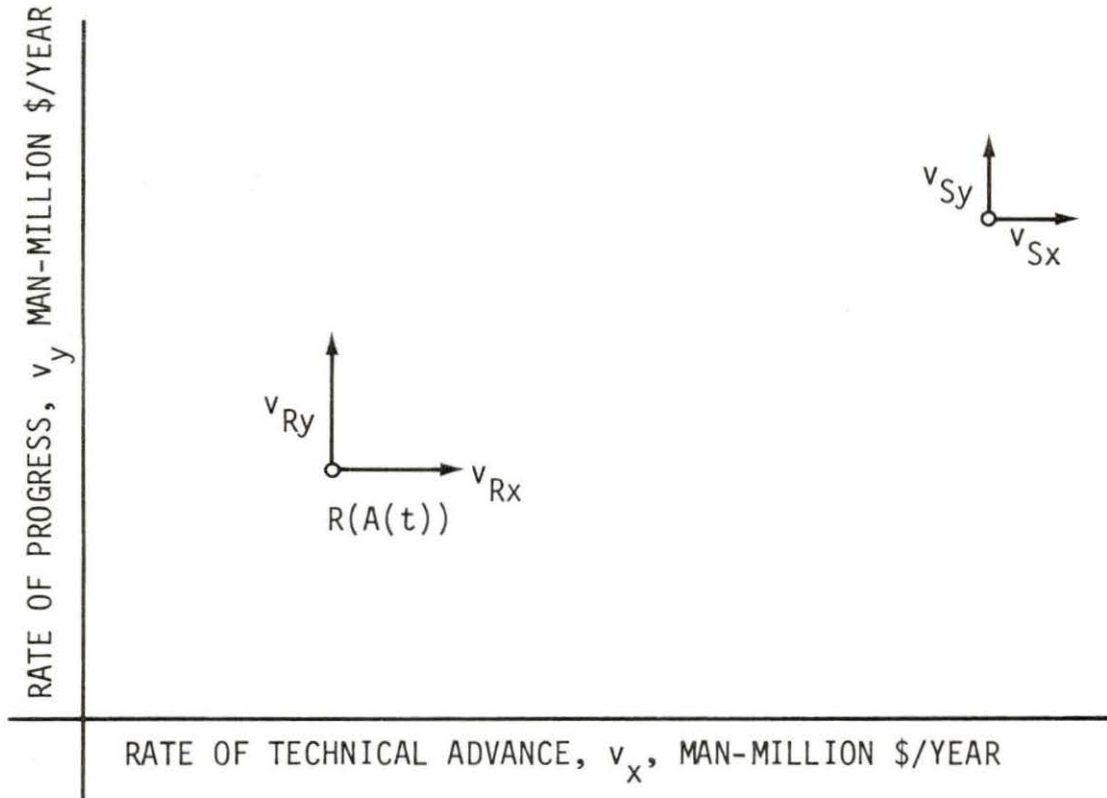

Figure 6.3. Representation of rates of change in the velocity space

veloping and developed countries respectively and  $v_{RX}$  and  $v_{SX}$  are the corresponding rates of technical advance. All rates are expressed in man-million \$/year.

The acceleration space would provide an insight in rate of annual changes of the state of both countries. The gap between the nonnuclear countries and nuclear countries can be bridged in progress, advances or both, on a shorter time scale if the acceleration of progress, advances or both, respectively, exceeds the corresponding acceleration in nuclear countries. A possible deceleration may take place in the reference nuclear country thus allowing the developing country to approach the optimum state  $A_0$  at a shorter time. This is in fact the current case in the United States where a great brake is applied on the rate of technical advances in the nuclear energy field.

The acceleration variables may be defined as follows, progress accelerations for R and S are  $a_{RY}$  and  $a_{SY}$ , respectively, and  $a_{RX}$  and  $a_{SX}$  being the corresponding advance accelerations.

The model can be extended to multidimensional representation to include other relevant variable other than progress and advancement. An n-space may be used to encompass all properties of the state space.



### 6.3. Uses of the Model

The planners in charge of the transfer of nuclear technology allocate specific yearly or five-years funds for their program. Usually, as the five-year plans end other plans come along before assessing the effect of the earlier plan takes place. Eliminating or adjustment of budgetary items are based on general feelings about success or failure of one project or another, this is along with the intrinsic political, cultural and human factors. By using the proposed model evaluation of the plan could be done by tracking the state variables  $X$ ,  $Y$ ,  $v_{iX}$  and  $v_{iY}$  where  $i = R, S$ . Adequate perception of the transfer of technology system as displayed by the model would result in proper system control through periodical adjustment of the plans. The corrective measures may include revision of the procedures, changes in yearly funds, increase in manpower, etc. The process is illustrated in Figure 6.4. The tasks of the planner in developed countries may only be monitored as a reference to adjust the plans of the developing country. However, the main review and control is the task of the planner in the developing country since it is unlikely that planners in developed countries will interfere in the flow of transfer of technology to developing countries. One exception is the possible restriction on information if the

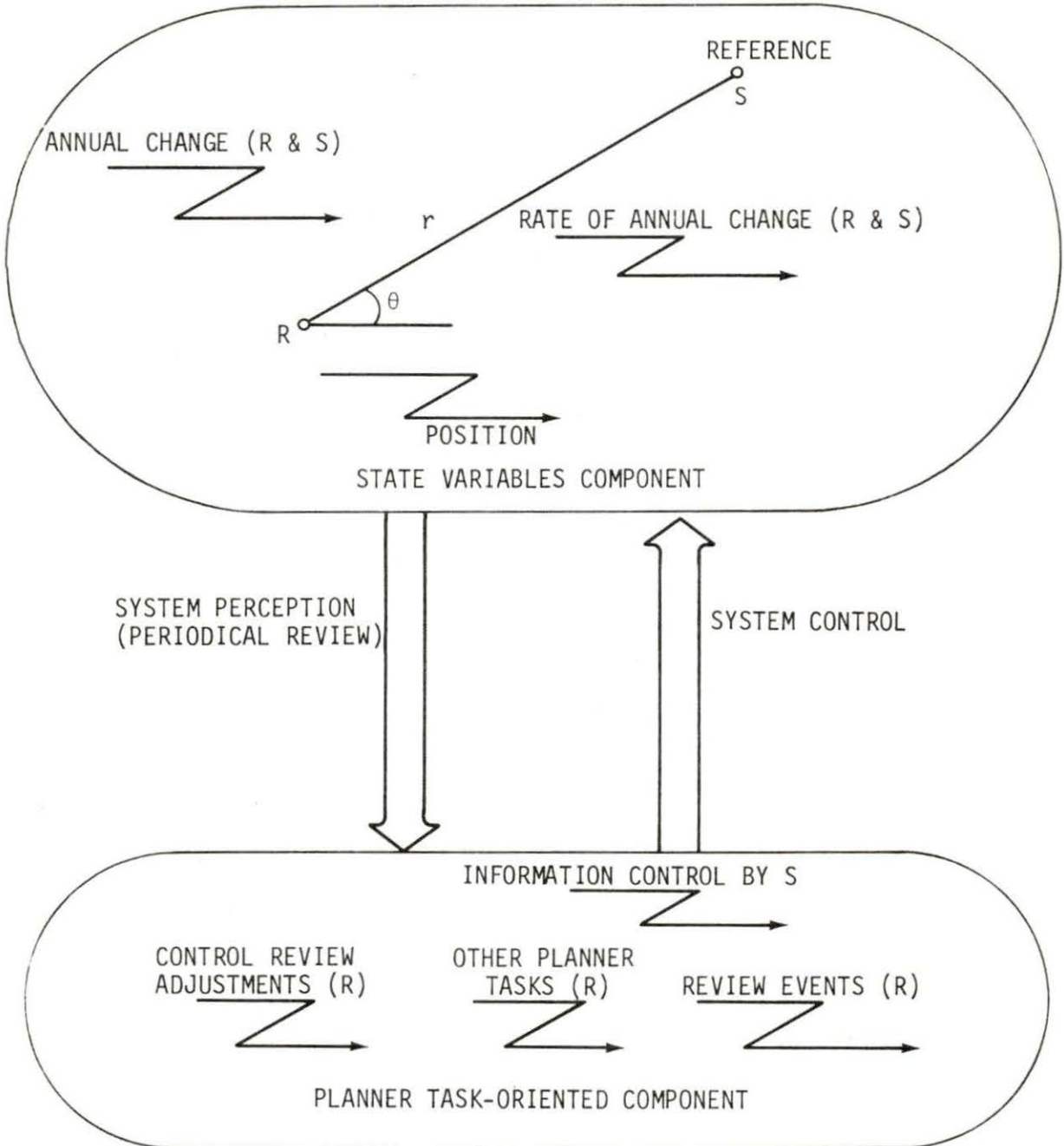

Figure 6.4. Transfer of technology plan review and control

direction of progress or advancement represented a threat of one sort or the other to the developed country.

The planner periodically (yearly) scans both the development distance and the phase angle in order to keep track of the status of  $r$  and  $\theta$ . When  $r$  and  $\theta$  are no longer within an acceptable range, the planner takes corrective action in terms of change in rates of progress or advances.

By modifying the state variables of the model other facets of the transfer of technology become amenable to analysis. The example cited here for the use of the model is a tracking type of task. In this case, the SAINT code may be used in the analysis provided initial values are given and the actual strategy of the planner is identified. A brief description of the SAINT code is given in Appendix C.

#### 6.4. Application of the Model

##### 6.4.1. Objective

The objective of this simulation study is to determine how well the planner in developing countries are able to implement transfer of nuclear technology plans towards an identified goal in the presence of uncertainties. In terms of the SAINT output statistics, the interest is in the percentage of time wherein  $r$  and  $\theta$  are within acceptable ranges.

#### 6.4.2. The approach

The indicator which specifies the status of the angle  $\theta$  is divided into three regions, as shown in Figure 6.5. The acceptable region is assumed to be within a range of  $\theta = 35^\circ$  to  $55^\circ$ . Irrelevant technical advancement occurs when  $\theta$  is too small, while the absence of technical advancement lies in the region of large  $\theta$ .

Figure 6.6 presents an indicator for the distance  $r$  similar to the indicator for the angle  $\theta$ . The indicator consists of five regions: two unacceptable regions, two partially acceptable regions and one acceptable region. The planner in developing countries may attempt to maintain the value of the distance  $r$  within an acceptable range of, say, 250 to 350 man-million \$.

The planner regularly scans both the distance and angle indicator in order to keep track of the status of  $r$  and  $\theta$ . Between scanning operations, it is possible that a change occurs in the relative achievement position of the two countries between which the transfer process is taking place. Table 6.1 lists the combinations of the  $r$  and  $\theta$  regions and the corresponding action to be taken when such combination prevails. As an example, if both  $r$  and  $\theta$  are in the unacceptable A regions, the planner of the developing country alters his relative transferring position to the developed

$\theta$

Unacceptable (A)	$35^{\circ}$  $55^{\circ}$
Acceptable	
Unacceptable (B)	

Figure 6.5. Range of angle  $\theta$ 

$r$

Unacceptable (A)	150  250  350  450
Partially acceptable (A)	
Acceptable	
Partially acceptable (B)	
Unacceptable (B)	

Figure 6.6. Range of distance  $r$



Table 6.1. Control strategy for nuclear technology transferring model

Condition	Task No.	Action Taken by Planner
r unacceptable - A	31	$V_{RX} = .9975 V_{TX}$
$\theta$ unacceptable - A		$V_{RY} = V_{TY} - 0.8$
r unacceptable - A	32	$V_{RX} = .9975 V_{TX}$
$\theta$ unacceptable - B		$V_{RY} = V_{TY} + 0.8$
r unacceptable - A	33	$V_{RX} = .999 V_{TX}$
$\theta$ acceptable		$V_{RY} = V_{TY} - 0.8$
r unacceptable - B	34	$V_{RX} = 1.003 V_{TX}$
$\theta$ unacceptable - A		$V_{RY} = V_{TY} - 0.8$
r unacceptable - B	35	$V_{RX} = 1.003 V_{TX}$
$\theta$ unacceptable - B		$V_{RY} = V_{TY} + 0.8$
r unacceptable - B	36	$V_{RX} = 1.001 V_{TX}$
$\theta$ acceptable		$V_{RY} = V_{TY} + 0.8$
r partially acceptable - A	37	$V_{RX} = .999 V_{TX}$
$\theta$ unacceptable - A		$V_{RY} = V_{TY} - 0.4$
r partially acceptable - A	38	$V_{RX} = .999 V_{TX}$
$\theta$ unacceptable - B		$V_{RY} = V_{TY} + 0.4$

Table 6.1 (Continued)

Condition	Task No.	Action Taken by Planner
r partially acceptable - A	39	$V_{RX} = .9995 V_{TX}$
$\theta$ unacceptable - B		$V_{RY} = V_{TY} - 0.4$
r partially acceptable - B	41	$V_{RX} = 1.001 V_{TX}$
$\theta$ unacceptable - A		$V_{RY} = V_{TY} - 0.4$
r partially acceptable - B	42	$V_{RX} = 1.001 V_{TX}$
$\theta$ unacceptable - B		$V_{RY} = V_{TY} + 0.4$
r partially acceptable - B	43	$V_{RX} = 1.001 V_{TX}$
$\theta$ acceptable		$V_{RY} = V_{TY} + 0.4$
r acceptable	44	$V_{RX} = 1.001 V_{TX}$
$\theta$ unacceptable - A		$V_{RY} = V_{TY} - 0.8$
r acceptable	45	$V_{RX} = .999 V_{TX}$
$\theta$ unacceptable - B		$V_{RY} = V_{TY} + 0.8$
r acceptable	-	None
$\theta$ acceptable		

country by decreasing both x and y velocities relative to the x and y velocities of the developed country at task 31 in the SAINT network. This action causes a desired increase in the values of both r and  $\theta$ .

#### 6.4.3. Initial conditions and state variable definitions

The initial conditions employed in the model, along with the corresponding SAINT variables, are listed in Table 6.2. The origin of the X-Y coordinate system is the recipient's position when transferring begins (the recipient's X and Y position are initially 0). For the nuclear country, the initial Y-position (SS(18)) is assumed to be 200 man-million and the initial X-position (SS(17)) is assumed to be 220 man-million.

The following formulas were used to convert the X and Y headways into the polar coordinates, r and  $\theta$ .

$$SS(19) = r = \sqrt{(SS(18))^2 + (SS(17))^2} \quad (6.3)$$

$$SS(20) = \theta = \text{ARSIN}(SS(18)/r) \quad (6.4)$$

for the initial conditions given in Table 6.2 these relationships give initial values of  $r = 297.32$  man-million and  $\theta = 42.27^\circ (0.7378 \text{ radians})$ , that is both r and  $\theta$  are within the acceptable regions.

Table 6.2. Initial conditions and corresponding SAINT variables employed in the transferring model

Nuclear Countries Variable	Initial Value	SAINT Variable
Y-acceleration ( $a_{TY}$ )	0	-
Y-velocity ( $V_{TY}$ )	800 man-million/year	SS(8)
Y-position ( $P_{TY}$ )	200 man-million/year	SS(4)
X-acceleration ( $a_{TX}$ )	0	-
X-velocity ( $V_{TX}$ )	800 man-million/year	SS(6)
X-position ( $P_{TX}$ )	200 man-million/year	SS(3)
Recipient Countries Variable	Initial Value	SAINT Variable
Y-acceleration ( $a_{RY}$ )	50 man-million/years <sup>2</sup>	-
Y-velocity ( $V_{RY}$ )	0	SS(7)
Y-position ( $P_{RY}$ )	0	SS(2)
X-acceleration ( $a_{RX}$ )	50 man-million/years <sup>2</sup>	-
X-velocity ( $V_{RX}$ )	0	SS(5)
X-position ( $P_{RX}$ )	0	SS(1)

#### 6.4.4. The SAINT model

Figure 6.7 shows the SAINT state variable diagram for this model. Velocities are obtained by integrating accelerations. For example, the output of node 4 is the position of the developed country in the Y-direction ( $P_{TY}$ ), or SS(4). The rate of change of SS(4) is  $V_{TY}$ , or SS(8). Hence,

$$\frac{dSS(4)}{dt} = SS(8) \quad (6.5)$$

or in SAINT notation,

$$DD(4) = SS(8). \quad (6.6)$$

The graphic symbols used for the equations governing the state variables are represented in Figure 6.8. The symbols for the monitors are shown in Figure 6.9. The monitor symbol is a rectangle and indicates the variable that is being monitored and specifies the threshold function. The threshold function consists of a multiplicative constant, M, an SS(.) or DD(.) variable, SS(V) or DD(V), and additive constant C, a direction indicator ( $\uparrow$ ,  $\downarrow$  or  $\updownarrow$ ) and tolerance, TOL to identified on the input (41).

The state equations are shown in Figure 6.10. The initial conditions are defined in subroutine INTLC, shown in Figure 6.11. Figure 6.12 displays the task network of the



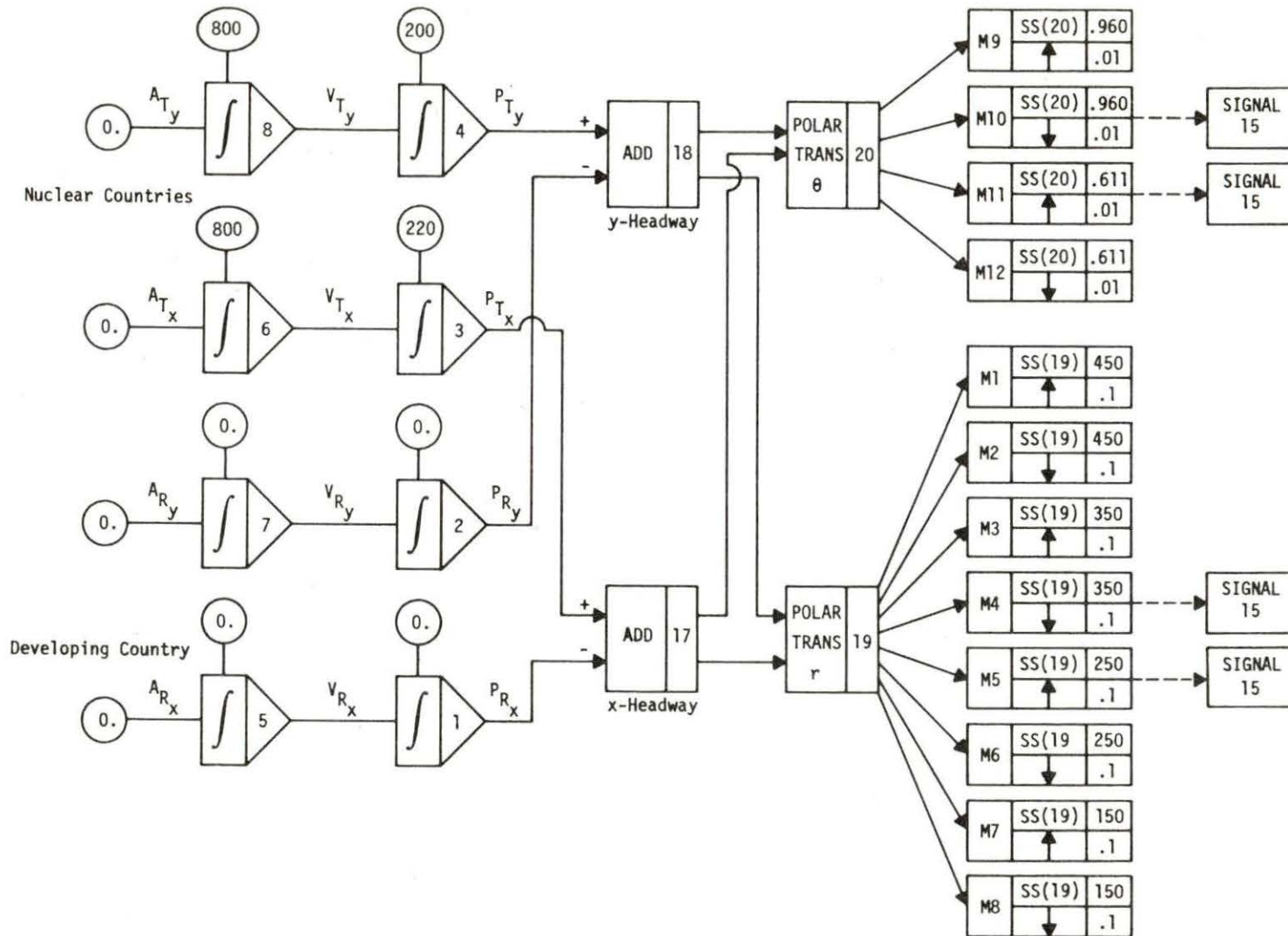

Figure 6.7. State variable network model of transferring process

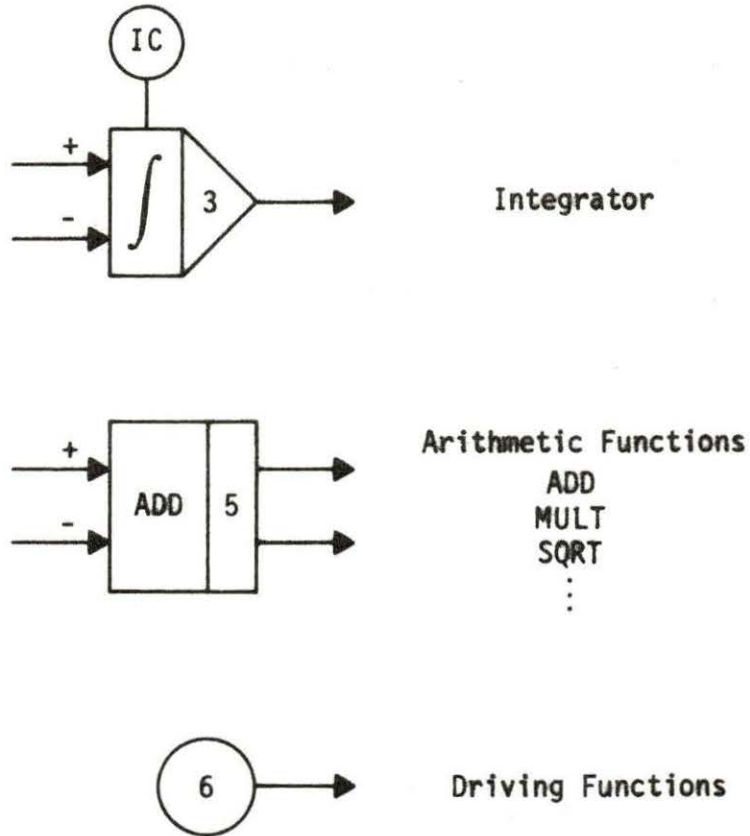
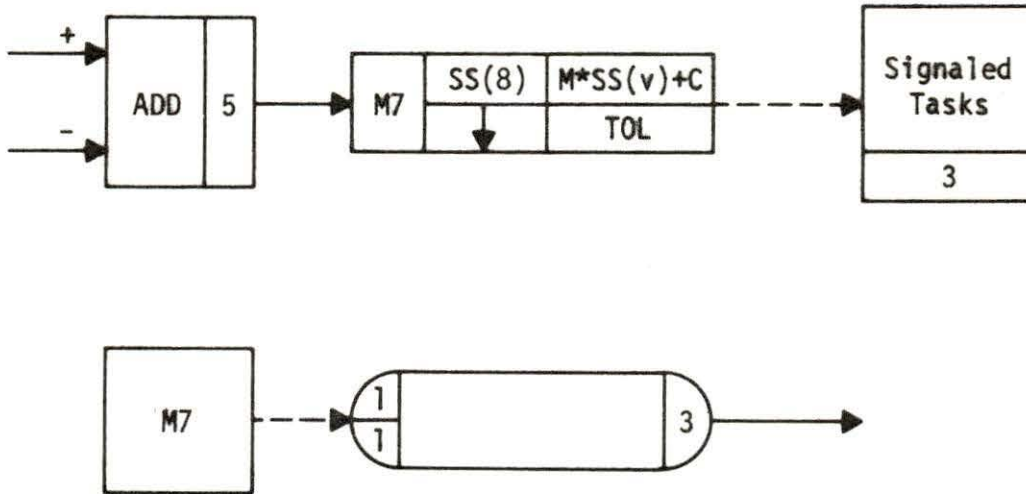

Figure 6.8. Symbols used for the state variables equations



Threshold Function:  $M*SS(v) + C$ .

Figure 6.9. Symbols for monitored variables and monitor action

```

1.      SUBROUTINE STATE
2.      COMMON/COM17/SS(100),SSL(100),DD(100),DDL(100),LLSVR(100,2)
3.      COMMON/COM18/IS(20),NABAD(300),YABAR(600)
4.      C
5.      C***DEFINE SWITCH VALUES EQUAL TO SS VARIABLES FOR STATE PURPOSES.
6.      C
7.          SS(21)=IS(3)
8.          SS(22)=IS(1)
9.          SS(23)=IS(5)
10.         SS(24)=IS(7)
11.      C
12.      C
13.      C**X-HEADWAY & Y-HEADWAY CALCULATIONS.
14.      C
15.          SS(17)=SS(3)-SS(1)
16.          SS(18)=SS(4)-SS(2)
17.      C
18.      C
19.      C**DISTANCE & THETA CALCULATIONS.
20.      C
21.          SS(19)=SQRT(SS(17)**2+SS(18)**2)
22.          SS(20)=ARSIN(SS(18)/SS(19))
23.      C
24.          DD(4)=SS(8)
25.          DD(3)=SS(6)
26.          DD(2)=SS(7)
27.          DD(1)=SS(5)
28.          RETURN
29.          END

```

Figure 6.10. Subroutine STATE for the transferring model

```

30.          SUBROUTINE INTLC
31.          COMMON/COM17/SS(100),SSL(100),DD(100),DDL(100),LLSUR(100,2)
32.          COMMON/COM18/IS(20),NABAD(300),YABAR(600)
33.          C***INITIALIZE SWITCHES.
34.          C
35.             DO 10 I=1,9
36.           10 IS(I)=0
37.             IS(3)=1
38.             IS(7)=1
39.             SS(21)=IS(3)
40.             SS(24)=IS(7)
41.          C
42.          C***INITIALIZE VELOCITIES (MAN-MILLION/YR).
43.          C
44.             SS(8)=800
45.             SS(7)=0.
46.             SS(6)=800
47.             SS(5)=0.
48.          C***INITIALIZE POSITION (MAN-MILLION).
49.          C
50.             SS(4)=200
51.             SS(3)=220
52.             SS(2)=0.
53.             SS(1)=0.
54.          C***DEFINE STARTS FOR PLOTTING PURPOSES.
55.          C
56.             SS(9)=45.
57.             SS(10)=60.
58.             SS(11)=450.
59.             SS(12)=350.
60.             SS(13)=250.
61.             SS(14)=150.
62.             SS(15)=.611
63.             SS(16)=.960
64.             RETURN
65.             END

```

Figure 6.11. Subroutine INTLC for the transferring model



model, which represents the scanning and controlling activities of the planner. The standard task symbol, is shown in Figure 6.13, where it contains four rows for descriptive information. However, only the information necessary to describe a task need to be shown on a task symbol. If fewer than four rows are needed, the remaining rows can be left blank. Each row is divided into two parts. The left-hand part contains the task description code and is used to identify the type of information that appears on the right-hand part of the row. This can be any of the available codes shown in Table 6.3. By using the description code, only the information necessary to describe a task need be shown on the task symbol. Figure 6.14 summarizes the SAINT modeling concepts.

Table 6.3. Task description codes

Description Code	Information Required by Description Code
LABL	label associated with task
TIME	performance time characteristics
PRTY	priority
RESR	resource requirements
MARK	marking information
PREC	completion precedence

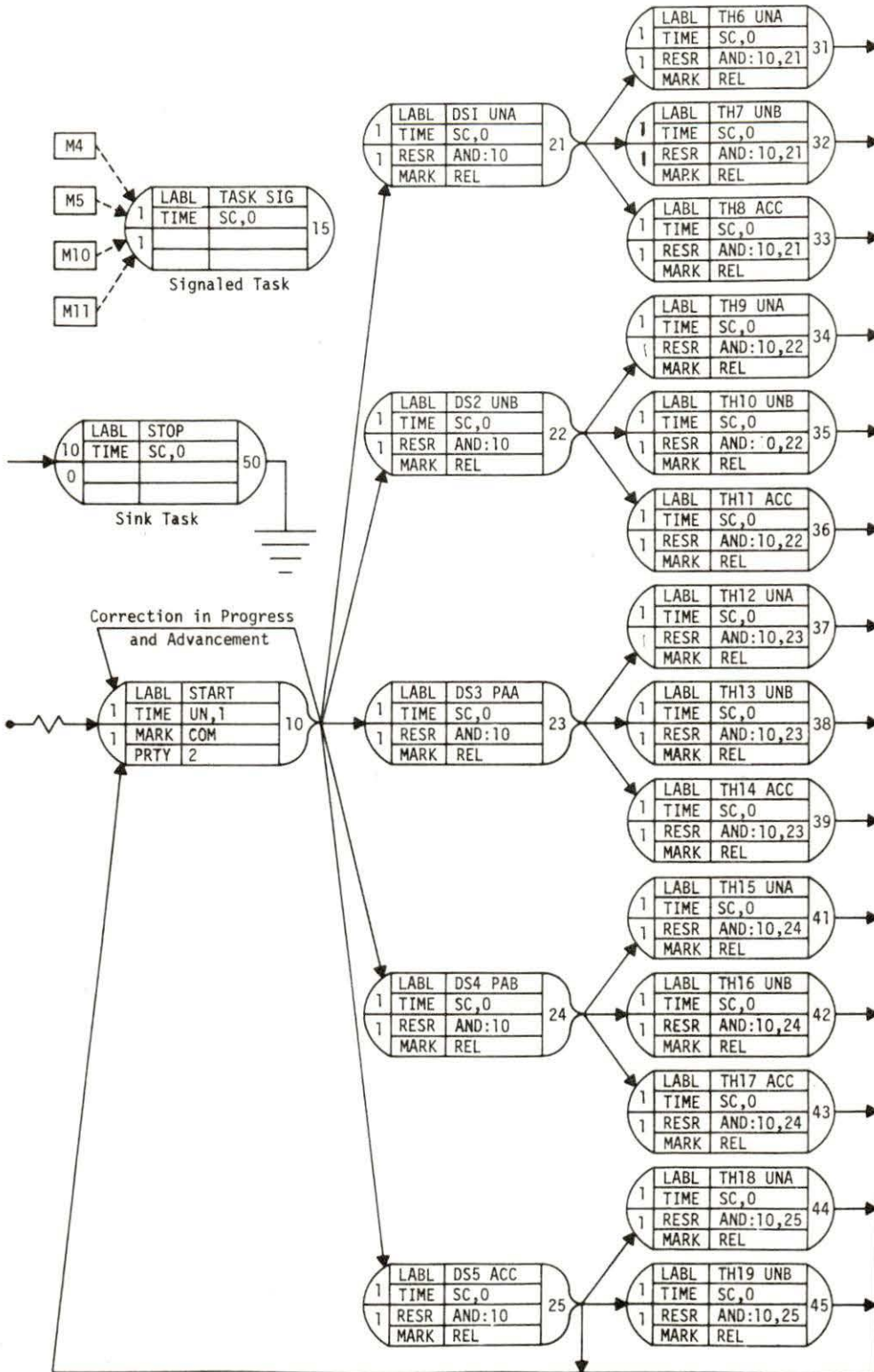

Figure 6.12. Task network model of transferring process

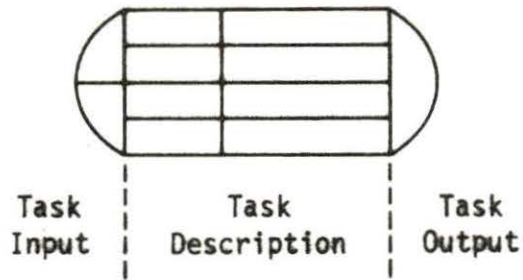

Figure 6.13. General representation of a SAINT task

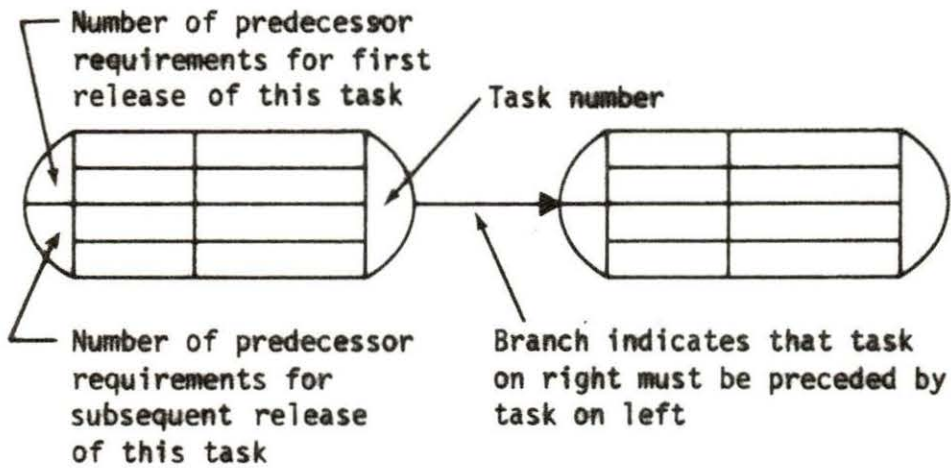

Figure 6.14. Summary of initial SAINT modeling concepts

In the model of the simple system shown in Figure 6.15, task 1 is released at the time the simulation begins. Thus, there are no predecessor tasks that must be completed before task 1 can be released. This type of task is referred to as "source task" and is indicated by the wavy input line to the left-hand side of the task symbol. In addition, the number "0" is placed in the upper left-hand portion of the task symbol to indicate that no predecessor tasks need to be completed prior to the first release of task 1.

In the same network model, task 2 requires that task 1 be completed before it can be released. The branch drawn from the output scale of task 1 to the input side of task 2 represents the required precedence relation. The number of predecessor task completions required for the first release of task 2 is specified in the upper left-hand corner of the task symbol and is 1. There is a feedback branch from task 2 to task 1. After both task 1 and task 2 have been completed, task 1 is released again. Since task 1 is to be released immediately following the completion of task 2, the number of predecessor requirements for subsequent release of task 1 is one as shown in the lower left-hand portion of the task symbol. In addition, since task 2 should be released immediately after the completion of task 1, the

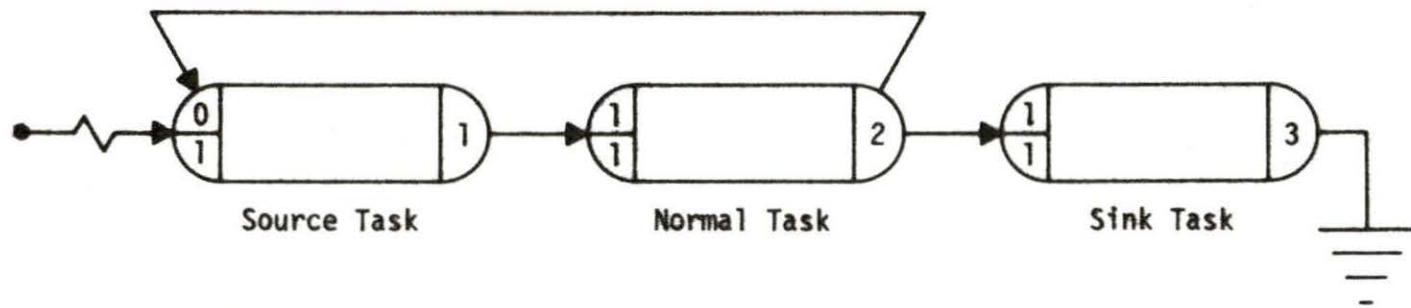

Figure 6.15. SAINT model illustrating tasks and precedence relations



number of predecessor requirements for subsequent release of task 2 is also set to 1. Task 3 is a sink task and branches to end simulation. No resources are required for the performance of this task, no attribute assignments are made at this task (41).

#### 6.4.5. Model input

The task-oriented and state variable components of the model are described on data cards. These are shown in Figure 6.16. A complete description of the SAINT data input requirements is presented in reference (42). SAINT input is

in free format, eliminating the need for values to be entered in specific card columns. The input fields are separated by commas. The first field of a card indicates the data type of that card.

SAINT outputs all input information as an echo check. This check is used to test for possible errors in the set-up of the code and the input information. The SAINT echo check is shown in Figures 6.17 through 6.26.

The objective of this input is to determine when corrections to the strategy have to be made assuming periodical checks of the flow of the transfer process. Whenever a deviation in the values of  $r$  or  $\theta$  is observed the strategy must be changed accordingly to return the development within the acceptable margins.

15. GEN,TAWFIK,4,25,1978,5,1,1,777777,1,Y\*  
 16. SGE,4,20,.005,.5,0,.05,.05,W\*  
 17. POP,1,1,8,0,,,2\*  
 18. OUT,1,1,1,1,1,1,1,1,1,1,1,Y,Y,Y,Y\*  
 19. DIS,1,NO,.5,0,1,.1\*  
 20. UBO,1,PROGTEST\*  
 21. UHI,1,PROGTEST,30,1,1\*  
 22. UPL,2,MONTH,1,B,2.\*  
 23. UVA,2,42,M,TH16 UNB,U,U,.25,2.5\*  
 24. LRE,1,PROGRES\*  
 25. LSV,1,PX-R,2,PY-R,3,PX-T,4,PY-T\*  
 26. LSV,5,VX-R,6,VX-T,7,VY-R,8,VY-T\*  
 27. LSV,9,PX-X,10,PY-Y,11,L-UN B,12,L-PA B\*  
 28. LSV,13,L-PA A,14,L-UN A,15,THUN B,16,THUN A\*  
 29. LSV,17,ADDX WAY,18,ADDY WAY\*  
 30. LSV,19,POLR R,20,POLR TH\*  
 31. LSV,21,SWITCH 3,22,SWITCH 1\*  
 32. LSV,23,SWITCH 5,24,SWITCH 7\*  
 33. TAS,10,START,1,1,DS,1,,,SO\*  
 34. TAS,20,RESTART,1,1,SC,0\*  
 35. TAS,15,TASK-SIG,1,1,SC,0\*  
 36. TAS,21,DS1 UNA,1,1,SC,0\*  
 37. TAS,22,DS2 UNB,1,1,SC,0\*  
 38. TAS,23,DS3 PAA,1,1,SC,0\*  
 39. TAS,24,DS4 PAB,1,1,SC,0\*  
 40. TAS,25,DS5 ACC,1,1,SC,0\*  
 41. TAS,31,TH6 UNA,1,1,SC,0\*  
 42. TAS,32,TH7 UNB,1,1,SC,0\*  
 43. TAS,33,TH8 ACC,1,1,SC,0\*  
 44. TAS,34,TH9 UNA,1,1,SC,0\*  
 45. TAS,35,TH10 UNB,1,1,SC,0\*  
 46. TAS,36,TH11 ACC,1,1,SC,0\*  
 47. TAS,37,TH12 UNA,1,1,SC,0\*  
 48. TAS,38,TH13 UNB,1,1,SC,0\*  
 49. TAS,39,TH14 ACC,1,1,SC,0\*  
 50. TAS,41,TH15 UNA,1,1,SC,0\*

Figure 6.16. SAINT input data for the transferring model

51. TAS,42,TH16 UNB,1,1,SC,0\*  
 52. TAS,43,TH17 ACC,1,1,SC,0\*  
 53. TAS,44,TH18 UNA,1,1,SC,0\*  
 54. TAS,45,TH19 UNB,1,1,SC,0\*  
 55. TAS,48,TURB 1,1,1,SC,12,,,SO\*  
 56. TAS,49,TURB 2,1,1,SC,10\*  
 57. TAS,50,STOP,10,0,SC,0,,,SI\*  
 58. ATA,10,,,,1,UF,1,,,2,UF,2,,,3,UF,3,,,4,UF,4,,,5,UF,5,,,6,UF,6\*  
 59. ATA,20,,,,7,UF,7\*  
 60. DET,31,10\*  
 61. DET,32,10\*  
 62. DET,33,10\*  
 63. DET,34,10\*  
 64. DET,35,10\*  
 65. DET,36,10\*  
 66. DET,37,10\*  
 67. DET,38,10\*  
 68. DET,39,10\*  
 69. DET,41,10\*  
 70. DET,42,10\*  
 71. DET,43,10\*  
 72. DET,44,10\*  
 73. DET,45,10\*  
 74. DET,48,49\*  
 75. DET,49,48,50\*  
 76. CFI,10,10,AGV,0,5,,,20,NO\*  
 77. CFI,20,23,AGV,0,6,,,24,AGV,0,7,,,21,AGV,0,2,,,22,AGV,0,1,,,25,NO\*  
 78. CFI,23,37,AGV,0,3,,,38,AGV,0,4,,,39,NO\*  
 79. CFI,24,41,AGV,0,3,,,42,AGV,0,4,,,43,NO\*  
 80. CFI,21,31,AGV,0,3,,,32,AGV,0,4,,,33,NO\*  
 81. CFI,22,34,AGV,0,3,,,35,AGV,0,4,,,36,NO\*  
 82. CFI,25,44,AGV,0,3,,,45,AGV,0,4,,,10,NO\*  
 83. SWI,15,9,0\*  
 84. SWI,21,9,1\*  
 85. SWI,22,9,1\*

Figure 6.16 (Continued)

86. SWI,23,9,1\*  
 87. SWI,24,9,1\*  
 88. SWI,44,9,1\*  
 89. SWI,45,9,1\*  
 90. SWI,48,9,0\*  
 91. SWI,49,9,0\*  
 92. REG,31,7,8,1.0,-0.8,E,5,6,0.9975,0,E\*  
 93. REG,32,7,8,1.0,0.8,E,5,6,0.9975,0,E\*  
 94. REG,33,7,8,1.0,-0.8,E,5,6,0.999,0,E\*  
 95. REG,34,7,8,1.0,-0.8,E,5,6,1.0025,0,E\*  
 96. REG,35,7,8,1.0,0.8,E,5,6,1.0025,0,E\*  
 97. REG,36,7,8,1.0,0.8,E,5,6,1.001,0,E\*  
 98. REG,37,7,8,1.0,-0.8,E,5,6,1.001,0,E\*  
 99. REG,38,7,8,1.0,0.8,E,5,6,0.999,0,E\*  
 100. REG,39,7,8,1.0,-0.4,E,5,6,0.999,0,E\*  
 101. REG,41,7,8,1.0,0.4,E,5,6,0.999,0,E\*  
 102. REG,42,7,8,1.0,-0.4,E,5,6,0.9995,0,E\*  
 103. REG,43,7,8,1.0,-0.4,E,5,6,1.001,0,E\*  
 104. REG,44,7,8,1.0,0.4,E,5,6,1.001,0,E\*  
 105. REG,45,7,8,1.0,0.4,E,5,6,1.0005,0,E\*  
 106. REG,15,5,6,1.000,0,E,7,8,1.000,0,E\*  
 107. REG,48,8,8,1.0,4.0,E,6,6,1.0,2.0,E\*  
 108. REG,49,8,8,1.0,-4.0,E,6,6,1.0,-2.0,E\*  
 109. MON,1,MM 1,19,0.,0.,450.,F,.1\*  
 110. MON,2,MM 2,19,0.,0.,450.,N,.1\*  
 111. MON,3,MM 3,19,0.,0.,350.,F,.1\*  
 112. MON,4,MM 4,19,0.,0.,350.,N,.1\*  
 113. MON,5,MM 5,19,0.,0.,250.,F,.1\*  
 114. MON,6,MM 6,19,0.,0.,250.,N,.1\*  
 115. MON,7,MM 7,19,0.,0.,150.,F,.1\*  
 116. MON,8,MM 8,19,0.,0.,150.,N,.1\*  
 117. MON,9,MM 9,20,0.,0.,.960,F,.01\*  
 118. MON,10,MM 10,20,0.,0.,.960,N,.01\*  
 119. MON,11,MM 11,20,0.,0.,.611,F,.01\*  
 120. MON,12,MM 12,20,0.,0.,.611,N,.01\*

Figure 6.16 (Continued)



121. MTA,4,15\*  
 122. MTA,5,15\*  
 123. MTA,10,15\*  
 124. MTA,11,15\*  
 125. MSW,1,4,0,5,1\*  
 126. MSW,2,5,0,4,1\*  
 127. MSW,3,3,0,4,1\*  
 128. MSW,4,4,0,3,1\*  
 129. MSW,5,2,0,3,1\*  
 130. MSW,6,3,0,2,1\*  
 131. MSW,7,1,0,2,1\*  
 132. MSW,8,2,0,1,1\*  
 133. MSW,9,7,0,8,1\*  
 134. MSW,10,8,0,7,1\*  
 135. MSW,11,6,0,7,1\*  
 136. MSW,12,7,0,6,1\*  
 137. SST,1,21,R,ACC,1\*  
 138. SST,2,22,UNA-A,0\*  
 139. SST,3,23,UNA-B,0\*  
 140. SST,4,24,T,ACC,1\*  
 141. FLO,1,MONTH,1,B,2.\*  
 142. VAR,1,1,19,R,LENGTH,U,U,200.,600.\*  
 143. VAR,1,2,20,T,THETA,U,U,.25,2.8\*  
 144. VAR,1,3,11,K,R,CHANG,U,U,300.,550.\*  
 145. VAR,1,4,13,H,R,CHANG,U,U,200.,310.\*  
 146. VAR,1,5,15,M,TH,CHANG,U,U,.25,3.5\*  
 147. VAR,1,6,16,N,TH,CHANG,U,U,.25,2.5\*  
 148. VAR,1,7,17,X,X,DIREC,U,U,20.,720.\*  
 149. VAR,1,8,18,Y,Y,DIREC,U,U,10.,610.\*  
 150. FIN\*

Figure 6.16 (Continued)



SAINT SIMULATION PROJECT 5 BY TAWFIK  
DATE 4/ 25/ 1978

## \*RUN PARAMETERS\*

PARAMETER	VALUE
NUMBER OF ITERATIONS	1
NUMBER OF SINK TASKS TO END ITERATION	1
INTEGER RANDOM NUMBER SEED	777777
SCALE FACTOR FOR FUNCTION SC	1.000

## \*PROGRAM OPTIONS\*

OPTION	CODE
NUMBER OF RESOURCES	1
NUMBER OF RESOURCE ATTRIBUTES PER RESOURCE	1
NUMBER OF INFORMATION ATTRIBUTES	8
NUMBER OF SYSTEM ATTRIBUTES	0
NUMBER OF MODERATOR FUNCTIONS	0
NETWORK MODIFICATION	
DISTRIBUTION SET MODIFICATION	
RANKING OF TASKS AWAITING SCHEDULING	2

## \*OUTPUT OPTIONS\*

OPTION	CODE
DETAILED ITERATION OUTPUT (BEGIN)	1
DETAILED ITERATION OUTPUT (END)	1
RESOURCE UTILIZATION SUMMARY (BEGIN)	1
RESOURCE UTILIZATION SUMMARY (END)	1
STATISTICS TASK SUMMARY (BEGIN)	1
STATISTICS TASK SUMMARY (END)	1
INITIAL/FINAL STATE VARIABLE VALUES (BEGIN)	1
INITIAL/FINAL STATE VARIABLE VALUES (END)	1
STATE VARIABLE STATISTICS (BEGIN)	1
STATE VARIABLE STATISTICS (END)	1
STATE VARIABLE PLOTS/TABLES (BEGIN)	1
STATE VARIABLE PLOTS/TABLES (END)	1
RESOURCE UTILIZATION SUMMARY REPORT	YES
STATISTICS TASK SUMMARY REPORT	YES
HISTOGRAM OUTPUT FOR STATISTICS TASKS	
SUMMARY FOR ITERATION 1	YES
SUMMARY REPORT	YES

Figure 6.17. Echo check-run parameters, program options, and output options

*TASK DEFINITIONS*														
TASK NUMBER	TASK LABEL	SPEC CHAR	PREDECESSOR FIRST	SUBS	REQTS DIFF	PERFORMANCE FUNC	PMTR	TIME RESR	TASK PRTY	INFO CODE	CHOICE ATRIB	COMP PREC	RESR CODE	RESOURCES ASSOCIATED WITH THIS TASK
10	START	SOU	1	1		DS	1		0.0	LAS		0.0	AND	
15	TASK-SIG		1	1		SC	0		0.0	LAS		0.0	AND	
20	RESTART		1	1		SC	0		0.0	LAS		0.0	AND	
21	DS1 UNA		1	1		SC	0		0.0	LAS		0.0	AND	
22	DS2 UNB		1	1		SC	0		0.0	LAS		0.0	AND	
23	DS3 PAA		1	1		SC	0		0.0	LAS		0.0	AND	
24	DS4 PAB		1	1		SC	0		0.0	LAS		0.0	AND	
25	DS5 ACC		1	1		SC	0		0.0	LAS		0.0	AND	
31	TH6 UNA		1	1		SC	0		0.0	LAS		0.0	AND	
32	TH7 UNB		1	1		SC	0		0.0	LAS		0.0	AND	
33	TH8 ACC		1	1		SC	0		0.0	LAS		0.0	AND	
34	TH9 JNA		1	1		SC	0		0.0	LAS		0.0	AND	
35	TH10 UNB		1	1		SC	0		0.0	LAS		0.0	AND	
36	TH11 ACC		1	1		SC	0		0.0	LAS		0.0	AND	
37	TH12 UNA		1	1		SC	0		0.0	LAS		0.0	AND	
38	TH13 UNB		1	1		SC	0		0.0	LAS		0.0	AND	
39	TH14 ACC		1	1		SC	0		0.0	LAS		0.0	AND	
41	TH15 UNA		1	1		SC	0		0.0	LAS		0.0	AND	
42	TH16 UNB		1	1		SC	0		0.0	LAS		0.0	AND	
43	TH17 ACC		1	1		SC	0		0.0	LAS		0.0	AND	
44	TH18 UNA		1	1		SC	0		0.0	LAS		0.0	AND	
45	TH19 UNB		1	1		SC	0		0.0	LAS		0.0	AND	
48	TURB 1	SOU	1	1		SC	12		0.0	LAS		0.0	AND	
49	TURB 2		1	1		SC	10		0.0	LAS		0.0	AND	
50	STOP	SIN	10	0		SC	0		0.0	LAS		0.0	AND	

Figure 6.18. Echo check-task definitions

\*ATTRIBUTE ASSIGNMENT INFORMATION\*

TASK NUMBER	ASSIGNMENT POINT	ASSIGNMENT TYPE	RESR NUMBER	ATRIB NUMBER	FUNCTION TYPE	PARAMETER SPEC
10	COM	IA		1	UF	1
		IA		2	UF	2
		IA		3	UF	3
		IA		4	UF	4
		IA		5	UF	5
		IA		6	UF	6
20	COM	IA		7	UF	7

Figure 6.19. Echo check-attribute assignment information

\*DETERMINISTIC BRANCHING\*

TASK NUMBER	-----SUCCESSOR TASKS-----	
31	10	
32	10	
33	10	
34	10	
35	10	
36	10	
37	10	
38	10	
39	10	
41	10	
42	10	
43	10	
44	10	
45	10	
48	49	
49	48	50

Figure 6.20. Echo check-deterministic branching

\*CONDITIONAL BRANCHING\*

TASK NUMBER	BRANCH TYPE	SUCC TASK	CONDITION CODE	ATRIB/ VALUE	ATRIB TYPE	RESR NUMBER	COMPARED ATTRIBUTE
10	FIR	10 20	AGV	0.0	IA		5
20	FIR	23 24 21 22 25	AGV AGV AGV AGV	0.0 0.0 0.0 0.0	IA IA IA IA		6 7 2 1
21	FIR	31 32 33	AGV AGV	0.0 0.0	IA IA		3 4
22	FIR	34 35 36	AGV AGV	0.0 0.0	IA IA		3 4
23	FIR	37 38 39	AGV AGV	0.0 0.0	IA IA		3 4
24	FIR	41 42 43	AGV AGV	0.0 0.0	IA IA		3 4
25	FIR	44 45 10	AGV AGV	0.0 0.0	IA IA		3 4

Figure 6.21. Echo check-conditional branching



```

*STATE VARIABLE GENERAL INFORMATION*
NUMBER OF EQUATIONS WRITTEN IN DD      =          4
NUMBER OF EQUATIONS WRITTEN IN SS      =          20
INTEGRATION ERROR OPTION                =          WARN
ABSOLUTE INTEGRATION ERROR ALLOWED     =    0.5000E-01
RELATIVE INTEGRATION ERROR ALLOWED     =    0.5000E-01
MINIMUM STEP SIZE                       =    0.5000E-02
MAXIMUM STEP SIZE                       =    0.5000E 00
COMMUNICATION INTERVAL                  =    0.0

```

```

*STATE VARIABLE DESCRIPTIONS*
STATE VARIABLE      STATE VARIABLE
NUMBER             LABEL
1                  PX-R
2                  PY-R
3                  PX-T
4                  PY-T
5                  VX-R
6                  VX-T
7                  VY-R
8                  VY-T
9                  PX-X
10                 PY-Y
11                 L-UN B
12                 L-PA B
13                 L-PA A
14                 L-UN A
15                 THUN B
16                 THUN A
17                 ADDX WAY
18                 ADDY WAY
19                 PCLR R
20                 PCLR TH
21                 SWITCH 3
22                 SWITCH 1
23                 SWITCH 5
24                 SWITCH 7

```

Figure 6.22. Echo check-state variable general information and state variable descriptions

\*STATE VARIABLE REGULATION CAUSED BY TASK COMPLETIONS\*

TASK CAUSING REGULATION	VARIABLE TO BE REGULATED	-----REGULATION FUNCTION-----			DIRECTION OF REGULATION
		MULTIPLICATIVE CONSTANT	* STATE VARIABLE	+ ADDITIVE CONSTANT	
15	SS( 5)	0.1000E 01	SS( 6)	0.0	TO
15	SS( 7)	0.1000E 01	SS( 8)	0.0	TO
31	SS( 7)	0.1000E 01	SS( 8)	-0.8000E 00	TO
31	SS( 5)	0.9975E 00	SS( 6)	0.0	TO
32	SS( 7)	0.1000E 01	SS( 8)	0.8000E 00	TO
32	SS( 5)	0.9975E 00	SS( 6)	0.0	TO
33	SS( 7)	0.1000E 01	SS( 8)	-0.8000E 00	TO
33	SS( 5)	0.9990E 00	SS( 6)	0.0	TO
34	SS( 7)	0.1000E 01	SS( 8)	-0.8000E 00	TO
34	SS( 5)	0.1002E 01	SS( 6)	0.0	TO
35	SS( 7)	0.1000E 01	SS( 8)	0.8000E 00	TO
35	SS( 5)	0.1002E 01	SS( 6)	0.0	TO
36	SS( 7)	0.1000E 01	SS( 8)	0.8000E 00	TO
36	SS( 5)	0.1001E 01	SS( 6)	0.0	TO
37	SS( 7)	0.1000E 01	SS( 8)	-0.8000E 00	TO
37	SS( 5)	0.1001E 01	SS( 6)	0.0	TO
38	SS( 7)	0.1000E 01	SS( 8)	0.8000E 00	TO
38	SS( 5)	0.9990E 00	SS( 6)	0.0	TO
39	SS( 7)	0.1000E 01	SS( 8)	-0.4000E 00	TO
39	SS( 5)	0.9990E 00	SS( 6)	0.0	TO
41	SS( 7)	0.1000E 01	SS( 8)	0.4000E 00	TO
41	SS( 5)	0.9990E 00	SS( 6)	0.0	TO
42	SS( 7)	0.1000E 01	SS( 8)	-0.4000E 00	TO
42	SS( 5)	0.9995E 00	SS( 6)	0.0	TO
43	SS( 7)	0.1000E 01	SS( 8)	-0.4000E 00	TO
43	SS( 5)	0.1001E 01	SS( 6)	0.0	TO
44	SS( 7)	0.1000E 01	SS( 8)	0.4000E 00	TO
44	SS( 5)	0.1001E 01	SS( 6)	0.0	TO
45	SS( 7)	0.1000E 01	SS( 8)	0.4000E 00	TO
45	SS( 5)	0.1000E 01	SS( 6)	0.0	TO
48	SS( 8)	0.1000E 01	SS( 8)	0.4000E 01	TO
48	SS( 6)	0.1000E 01	SS( 6)	0.2000E 01	TO
49	SS( 8)	0.1000E 01	SS( 8)	-0.4000E 01	TO
49	SS( 6)	0.1000E 01	SS( 6)	-0.2000E 01	TO

Figure 6.23. Echo check-state variable regulation caused by task completions

*STATE VARIABLE MONITORS*							
THRESHOLD SPECIFICATION							
MONITOR NUMBER	MONITGR LAJEL	VARIABLE TO BE MONITORED	-----THRESHOLD FUNCTION-----			CROSSING DIRECTION	TOLERANCE SPECIFICATION
			MULTIPLICATIVE CONSTANT	* STATE VARIABLE	+ ADDITIVE CONSTANT		
1	MM 1	SS( 19)			0.4500E 03	UP	0.1000E 00
2	MM 2	SS( 19)			0.4500E 03	DCWN	0.1000E 00
3	MM 3	SS( 19)			0.3500E 03	UP	0.1000E 00
4	MM 4	SS( 19)			0.3500E 03	DCWN	0.1000E 00
5	MM 5	SS( 19)			0.2500E 03	UP	0.1000E 00
6	MM 6	SS( 19)			0.2500E 03	DCWN	0.1000E 00
7	MM 7	SS( 19)			0.1500E 03	UP	0.1000E 00
8	MM 8	SS( 19)			0.1500E 03	DCWN	0.1000E 00
9	MM 9	SS( 20)			0.9600E 00	UP	0.1000E-01
10	MM 10	SS( 20)			0.9600E 00	DCWN	0.1000E-01
11	MM 11	SS( 20)			0.6110E 00	UP	0.1000E-01
12	MM 12	SS( 20)			0.6110E 00	DCWN	0.1000E-01

Figure 6.24. Echo check-state variable monitors

\*SWITCHING CAUSED BY MONITOR ACTION\*

MONITOR NUMBER	SWITCH AFFECTED	NEW SWITCH VALUE
1	4	0
	5	1
2	5	0
	4	1
3	3	0
	4	1
4	4	0
	3	1
5	2	0
	3	1
6	3	0
	2	1
7	1	0
	2	1
8	2	0
	1	1
9	7	0
	8	1
10	8	0
	7	1
11	6	0
	7	1
12	7	0
	6	1

\*TASK SIGNALING CAUSED BY MONITOR ACTION\*

MONITOR NUMBER	TASKS TO BE SIGNALLED
4	15
5	15
10	15
11	15

Figure 6.25. Echo check-task signaling and switching caused by monitor action

\*STATE VARIABLE STATISTICS\*

STATE VARIABLE	STATISTIC LABEL	INITIAL VALUE (FOR STATISTICS ONLY)
SS( 21)	R.ACC	0.1000E 01
SS( 22)	UNA-A	0.0
SS( 23)	UNA-B	0.0
SS( 24)	T.ACC	0.1000E 01

\*STATE VARIABLE PLOT NUMBER 1\*

LABEL OF INDEPENDENT AXIS	=	MONTH
PERIPHERAL STORAGE UNIT NUMBER	=	1
NUMBER OF VARIABLES ON PLOT	=	8
PLOT/TABLE OPTION CODE	=	BOTH
PLOTTING INTERVAL	=	0.2000E 01

PLOTTED VARIABLE	PLOT SYMBOL	IDENTIFYING LABEL	LOW SCALE VALUE OPTION	HIGH SCALE VALUE OPTION	LOW SCALE VALUE	HIGH SCALE VALUE
SS( 19)	R	LENGTH	VAL	VAL	0.2000E 03	0.1000E 04
SS( 20)	T	THETA	VAL	VAL	0.2500E 00	0.2800E 01
SS( 11)	K	R.CHANG	VAL	VAL	0.3000E 03	0.5500E 03
SS( 13)	H	R.CHANG	VAL	VAL	0.2000E 03	0.3100E 03
SS( 15)	M	TH.CHANG	VAL	VAL	0.2500E 00	0.3500E 01
SS( 16)	N	TH.CHANG	VAL	VAL	0.2500E 00	0.2500E 01
SS( 17)	X	X.DIREC	VAL	VAL	0.2000E 02	0.7200E 03
SS( 18)	Y	Y.DIREC	VAL	VAL	0.1000E 02	0.6100E 03

Figure 6.26. Echo check-state variable statistics and state variable plot information



#### 6.4.6. Model output

The state variable values at time 0.0 and 220 months for iteration 1 are shown in Figures 6.27 and 6.28, respectively. The plot of  $r$  and  $\theta$  is shown in part in Figure 6.29. The independent axis is time and is recorded in months. The dependent axis is used to plot 8 variables. The plot defines each symbol plotted, as well as the scale used for plotting. For example, the length is plotted with the symbol R. The scale ranges from 200 to 1000 man-million \$. Quarter, half and three-quarter marks are computed as 400, 600 and 800 man-million \$ respectively. The symbol T is used to represent  $\theta$ , with the scale ranging from .25 to 2.8 radians. The following 4 variables represent thresholds of  $r$  and  $\theta$ . They are plotted so that the graphical behavior of  $r$  and  $\theta$  may be easily interpreted. The symbols K, H are used for threshold values on  $r$ , the symbols M, N for those of  $\theta$ . The variables SS(17) and SS(18) for X and Y-headway man-million \$ are plotted with the symbols X and Y respectively.

The table shown in Appendix C.2 provides the precise values of the plotted variables. The detailed iteration output indicates the exact times of task completions. It is shown in Appendix C.3. By using the three types of output together, an extremely clear picture of the dynamic behavior of the model can be obtained.

\*\*STATE VARIABLE VALUES AT TIME 0.0 FOR ITERATION 1\*\*

STATE VARIABLE (I)	STATE VARIABLE LABEL	SS(I)	DD(I)
1	PX-R	0.0	0.C
2	PY-R	0.0	0.C
3	PX-T	0.2200E 03	0.8000E 03
4	PY-T	0.2000E 03	0.8000E 03
5	VX-R	0.0	0.0
6	VX-T	0.8000E 03	0.C
7	VY-R	0.0	0.0
8	VY-T	0.8000E 03	0.C
9	PX-X	0.4500E 02	0.C
10	PY-Y	0.6000E 02	0.C
11	L-UN B	0.4500E 03	0.C
12	L-PA B	0.3500E 03	0.C
13	L-PA A	0.2500E 03	0.C
14	L-UN A	0.1500E 03	0.C
15	THUN B	0.6110E 00	0.0
16	THUN A	0.9600E 00	0.0
17	ADDX WAY	0.2200E 03	0.C
18	ADDY WAY	0.2000E 03	0.C
19	PDLR R	0.2973E 03	0.C
20	PDLR TH	0.7378E 00	0.0
21	SWITCH 3	0.1000E 01	0.0
22	SWITCH 1	0.0	0.C
23	SWITCH 5	0.0	0.0
24	SWITCH 7	0.1000E 01	0.0

Figure 6.27. State variable values at time 0.0 month

\*\*STATE VARIABLE VALUES AT TIME 0.2200E 03 FOR ITERATION 1\*\*

STATE VARIABLE (I)	STATE VARIABLE LABEL	SS(I)	DD(I)
1	PX-R	0.1759E 06	0.8028E 03
2	PY-R	0.1762E 06	0.8048E 03
3	PX-T	0.1764E 06	0.8020E 03
4	PY-T	0.1766E 06	0.8040E 03
5	VX-R	0.8028E 03	0.0
6	VX-T	0.8000E 03	0.0
7	VY-R	0.8048E 03	0.0
8	VY-T	0.8000E 03	0.0
9	PX-X	0.4500E 02	0.0
10	PY-Y	0.6000E 02	0.0
11	L-UN B	0.4500E 03	0.0
12	L-PA B	0.3500E 03	0.0
13	L-PA A	0.2500E 03	0.0
14	L-UN A	0.1500E 03	0.0
15	THUN B	0.6110E 00	0.0
16	THUN A	0.9600E 00	0.0
17	ADDX WAY	0.4512E 03	0.0
18	ADDY WAY	0.4303E 03	0.0
19	POLR R	0.6234E 03	0.0
20	POLR TH	0.7616E 00	0.0
21	SWITCH 3	0.0	0.0
22	SWITCH 1	0.0	0.0
23	SWITCH 5	0.1000E 01	0.0
24	SWITCH 7	0.1000E 01	0.0

Figure 6.28. State variable values at time 220 months

\*\*STATE VARIABLE PLOT 1 FOR ITERATION 1\*\*

		SCALES OF PLOT																				
R=LENGTH	0.2000E 03	0.4000E 03	0.6000E 03	0.8000E 03	0.1000E 04																	
T=THETA	0.2500E 00	0.8875E 00	0.1525E 01	0.2162E 01	0.2800E 01																	
K=R.CHANG	0.3000E 03	0.3625E 03	0.4250E 03	0.4875E 03	0.5500E 03																	
H=R.CHANG	0.2000E 03	0.2275E 03	0.2550E 03	0.2825E 03	0.3100E 03																	
M=TH.CHANG	0.2500E 00	0.1063E 01	0.1875E 01	0.2688E 01	0.3500E 01																	
N=TH.CHANG	0.2500E 00	0.8125E 00	0.1375E 01	0.1938E 01	0.2500E 01																	
X=X.DIREC	0.2000E 02	0.1950E 03	0.3700E 03	0.5450E 03	0.7200E 03																	
Y=Y.DIREC	0.1000E 02	0.1600E 03	0.3100E 03	0.4600E 03	0.6100E 03																	
MONTH	0	5	10	15	20	25	30	35	40	45	50	55	60	65	70	75	80	85	90	95	100	DUPLICATES
0.0	+		MR	R	RRTT	R	RXRNX	XXYYYYYX	XXYH	YYYY			K			+		R X				Y+ NY TR XR YX NR
0.2000E 01	+		M	T	+	N			H	+			K			+		RR X				Y+
0.4000E 01	+		M	T	+	N			H	+			K			+		R X				Y+
0.6000E 01	+		M	T	+	N			H	+			K			+		R X				YY+
0.8000E 01	+		M	T	+	N			H	+			K			+		R X				Y+
0.1000E 02	+		M	T	+	N			H	+			K			+		RR X				Y+
0.1200E 02	+		M	T	+	N			H	+			K			+		R X				Y+
0.1400E 02	+		M	T	+	N			H	+			K			+		R X				Y+
0.1600E 02	+		M	T	+	N			H	+			K			+		R X				YY+
0.1800E 02	+		M	T	+	N			H	+			K			+		RR XX				Y+
0.2000E 02	+		M	T	+	N			H	+			K			+		R X				Y+
0.2200E 02	+		M	T	+	N			H	+			K			+		R X				YY+
0.2400E 02	+		M	T	+	N			H	+			K			+		RR X				Y+
0.2600E 02	+		M	T	+	N			H	+			K			+		R XX				Y+
0.2800E 02	+		M	T	+	N			H	+			K			+		R X				YY+
0.3000E 02	+		M	T	+	N			H	+			K			+		R X				Y+
0.3200E 02	+		M	T	+	N			H	+			K			+		R X				Y+
0.3400E 02	+		M	T	+	N			H	+			K			+		R X				Y+
0.3600E 02	+		M	T	+	N			H	+			K			+		R X				Y+
0.3800E 02	+		M	T	+	N			H	+			K			+		R X				Y+
0.4000E 02	+		M	T	+	N			H	+			K			+		R X				Y+
0.4200E 02	+		M	T	+	N			H	+			K			+		RR X				Y+
0.4400E 02	+		M	T	+	N			H	+			K			+		R X				Y+
0.4400E 02	+		M	T	+	N			H	+			K			+		R XX				YY+
0.4600E 02	+		M	T	+	N			H	+			K			+		RR X				Y+
0.4800E 02	+		M	T	+	N			H	+			K			+		R X				Y+
0.5000E 02	+		M	T	+	N			H	+			K			+		R X				Y+
0.5200E 02	+		M	T	+	N			H	+			K			+		R X				YY+
0.5400E 02	+		M	T	+	N			H	+			K			+		R X				Y+
0.5600E 02	+		M	T	+	N			H	+			K			+		R X				Y+
0.5800E 02	+		M	T	+	N			H	+			K			+		R X				Y+
0.6000E 02	+		M	T	+	N			H	+			K			+		R X				Y+
0.6200E 02	+		M	T	+	N			H	+			K			+		R X				YY+
0.6400E 02	+		M	T	+	N			H	+			K			+		RR XX				Y+
0.6600E 02	+		M	T	+	N			H	+			K			+		R X				Y+
0.6800E 02	+		M	T	+	N			H	+			K			+		R X				Y+
0.7000E 02	+		M	T	+	N			H	+			K			+		R X				Y+
0.7200E 02	+		M	T	+	N			H	+			K			+		R X				Y+
0.7400E 02	+		M	T	+	N			H	+			K			+		R X				YY+
0.7600E 02	+		M	T	+	N			H	+			K			+		R X				Y+
0.7800E 02	+		M	T	+	N			H	+			K			+		R X				Y+
0.8000E 02	+		M	T	+	N			H	+			K			+		R XX				YY+
0.8200E 02	+		M	T	+	N			H	+			K			+		RR X				Y+
0.8400E 02	+		M	T	+	N			H	+			K			+		R X				Y+
0.8600E 02	+		M	T	+	N			H	+			K			+		R X				Y+
0.8800E 02	+		M	T	+	N			H	+			K			+		RR XX				Y+
0.9000E 02	+		M	T	+	N			H	+			K			+		R X				Y+

Figure 6.29. State variable plot for iteration 1

0.9200E 02	+	M	T	+	N	H	+	K	R	+X	Y	+
0.9400E 02	+	M	T	+	N	H	+	K	R	+X	Y	+
0.9600E 02	+	M	T	+	N	H	+	K	R	+X	YY	+
0.9800E 02	+	M	T	+	N	H	+	K	R	X	Y	+
0.1000E 03	+	M	T	+	N	H	+	K	R	X	Y	+
0.1020E 03	+	M	T	+	N	H	+	K	RR	X	Y	+
0.1040E 03	+	M	T	+	N	H	+	K	R	X	Y	+
0.1060E 03	+	M	T	+	N	H	+	K	R	XX	YY	+
0.1080E 03	+	M	T	+	N	H	+	K	R	XX	Y	+
0.1100E 03	+	M	T	+	N	H	+	K	RR	X+	YY	+
0.1120E 03	+	M	T	+	N	H	+	K	R	XX	Y	+
0.1140E 03	+	M	T	+	N	H	+	K	R	XX+	Y	+
0.1160E 03	+	M	T	+	N	H	+	K	RR	X+	Y	+
0.1180E 03	+	M	T	+	N	H	+	K	R	X+	YY	+
0.1200E 03	+	M	T	+	N	H	+	K	R	X+	Y	+
0.1220E 03	+	M	T	+	N	H	+	K	R	X+	Y	+
0.1240E 03	+	M	T	+	N	H	+	K	RR	XX+	Y	+
0.1260E 03	+	M	T	+	N	H	+	K	R	X+	YY	+
0.1280E 03	+	M	T	+	N	H	+	K	R	X+	Y	+
0.1300E 03	+	M	T	+	N	H	+	K	RR	X+	Y	+
0.1320E 03	+	M	T	+	N	H	+	K	R	XX+	YY	+
0.1340E 03	+	M	T	+	N	H	+	K	RR	X+	Y	+
0.1360E 03	+	M	T	+	N	H	+	K	R	X+	YY	+
0.1380E 03	+	M	T	+	N	H	+	K	R	X+	YY	+
0.1400E 03	+	M	T	+	N	H	+	K	R	XX+	Y	+
0.1420E 03	+	M	T	+	N	H	+	K	RR	X+	Y	+
0.1440E 03	+	M	T	+	N	H	+	K	R	X+	Y	+
0.1460E 03	+	M	T	+	N	H	+	K	R	X+	YY	+
0.1480E 03	+	M	T	+	N	H	+	K	R	XX+	Y	+
0.1500E 03	+	M	T	+	N	H	+	K	RR	X+	Y	+
0.1520E 03	+	M	T	+	N	H	+	K	R	X+	Y	+
0.1540E 03	+	M	T	+	N	H	+	K	R	X+	YY	+
0.1560E 03	+	M	T	+	N	H	+	KRR	XX	+ Y	+	+
0.1580E 03	+	M	T	+	N	H	+	KR	X	+ Y	+	+
0.1600E 03	+	M	T	+	N	H	+	KR	X	+ YY	+	+
0.1620E 03	+	M	T	+	N	H	+	KR	X	+ Y	+	+
0.1640E 03	+	M	T	+	N	H	+	KR	X	+ Y	+	+
0.1660E 03	+	M	T	+	N	H	+	R	XX	+ Y	+	+
0.1680E 03	+	M	T	+	N	H	+	R	X	+ Y	+	+
0.1700E 03	+	M	T	+	N	H	+	R	X	+YY	+	+
0.1720E 03	+	M	T	+	N	H	+	RR	X	+Y	+	+
0.1740E 03	+	M	T	+	N	H	+	RK	X	+Y	+	+
0.1760E 03	+	M	T	+	N	H	+	RK	XX	YY	+	+
0.1780E 03	+	M	T	+	N	H	+	RRK	X	Y	+	+
0.1800E 03	+	M	T	+	N	H	+	R K	X	Y	+	+
0.1820E 03	+	M	T	+	N	H	+	R K	X	Y	+	+
0.1840E 03	+	M	T	+	N	H	+	R K	XX	Y+	+	+
0.1860E 03	+	M	T	+	N	H	+	R K	X	Y+	+	+
0.1880E 03	+	M	T	+	N	H	+	R K	X	Y+	+	+
0.1900E 03	+	M	T	+	N	H	+	R K	X	Y+	+	+
0.1920E 03	+	M	T	+	N	H	+	R K	X	Y+	+	+
0.1940E 03	+	M	T	+	N	H	+	RR	K	XX	Y+	+
0.1960E 03	+	M	T	+	N	H	+	R	K	X	Y+	+
0.1980E 03	+	M	T	+	N	H	+	R	K	X	Y+	+
0.2000E 03	+	M	T	+	N	H	+	RR	K	X	YY+	+
0.2020E 03	+	M	T	+	N	H	+	R	K	XX	Y+	+
0.2040E 03	+	M	T	+	N	H	+	R	K	X	Y+	+
0.2060E 03	+	M	T	+	N	H	+	R	K	X	Y+	+
0.2080E 03	+	M	T	+	N	H	+	RR	K	X	Y+	+
0.2100E 03	+	M	T	+	N	H	+	R	K	X	Y+	+

Figure 6.29 (Continued)



In spite of the disturbance, the angle  $\theta$  remains within the acceptable region. However,  $r$  moves into the unacceptable region most of the time. This condition is detected by monitor 3 at time .05 month, and by monitor 1 at time .14 month just after starting the simulation. This is shown clearly in the detailed iteration output.

This three types SAINT output employed in the above discussion provides an excellent picture of the system's dynamic behavior, and can be used to follow the transferring process of nuclear technology to its completion at time 220 months.

Figure 6.30 shows the state variable statistical values obtained over the entire 220 months simulation. The results indicate that  $\theta$  was in the acceptable region throughout the simulation. The length  $r$  was in the acceptable region .022% of the time, the unacceptable region 99.94% of the time.

The above results indicate that the control strategy used performed quite well. However, this model illustrated how SAINT can be used to follow the process of nuclear technology transfer from the developed countries to developing countries, in detail.

\*\*STATE VARIABLE STATISTICS FOR ITERATION 1\*\*

STATE VARIABLE	STATISTIC LABEL	AVERAGE	MINIMUM	MAXIMUM	TIME INTERVAL
SS( 21)	R.ACC	0.2194E-03	0.0	0.1000E 01	0.2200E 03
SS( 22)	UNA-A	0.0	0.0	0.0	0.2200E 03
SS( 23)	UNA-B	0.9994E 00	0.0	0.1000E 01	0.2200E 03
SS( 24)	T.ACC	0.1000E 01	0.1000E 01	0.1000E 01	0.2200E 03

Figure 6.30. State variable statistics for iteration 1

## 7. CONCLUSIONS AND RECOMMENDATIONS

Examination of the indigent ideology and its impact on transfer of technology in general and nuclear technology in particular has shown that adherence to the ideology prevailing in Saudi Arabia would greatly assist in establishing the adequate environment for the transfer process. This is due to the fact that great emphasis is placed by the traditions upon dedication, quality assurance, occupational and public safety, environment and ecology protection, productivity and stability. The element of stability which is a byproduct of the permanent and immutable character of Islam would eliminate the possibility of transfer of unviable technologies and would discourage the misuse of nuclear technology. The indigent ideology would prevent the impact of technocracy which could accompany the technology transfer. That is, a great resistance to change in family structure, to female emancipation, and to age discrimination is likely to take place. Such resistance will not hinder the technology transfer but will restrict the flow of associated ideologies.

Social and cultural factors tend to change with time and may deviate from the ideological norm. The Saudi Arabian society has been traditionally receptive to compatible foreign cultures. In fact, the long history of involvement in trade with foreign countries had eliminated nationalism

biases and have enhanced exchange of information and technology transfer. However, the current economical growth and the first development rate have created extreme shortages in technical manpower. Also, resentment has been developing towards labor and technological endeavors. Such phenomenon can be detrimental to the transfer process unless the ideological traditions are revived.

A survey of a sample of Saudi Arabians from different walks of life has shown great enthusiasm towards participation in nuclear technology development. However, a serious training program is found to be one of the major steps which is needed towards successful transfer of such technology. The present research and development program and safety and quality assurance awareness need to be greatly improved. Availability of adequate finance at the present time provides a great incentive to start the transfer process immediately.

A strategy of transfer of nuclear technology is proposed in a way compatible with the nature of the country and its people. Special attention must be paid to establishing research and development institutions, training centers, international information exchange media and special committees to oversee the progress in nuclear energy transfer. An objective of commissioning three 1 TWe plants in the east, center and west regions by the year 2000 would assure



prosperity in presence or decline in oil revenues.

Three paths to achieve the strategy objectives are analyzed; namely, importing nuclear power stations, local participation in operation and adaptation of nuclear technology to the local environment. The adaption alternative is found to be the most viable policy decision since this option has the highest utility for the country considering various economic and social factors.

Various models and system analysis techniques are found adequate for extensive use in planning nuclear technology programs. A system is also developed to track the progress of any program under uncertainties to allow the planner to allocate appropriate funds and manpower to assure success of the program.

Application of some of the models to specific situations in which there is a current nuclear technology transfer program using field data would provide a diagnostic tool to evaluate causes of progress or regress in such programs. It is recommended here that such models be applied to present transfer plans to countries such as Iran, India, Egypt, Korea and Pakistan due to their active engagement in nuclear technology.



## 8. REFERENCES

1. A. F. Abdul-Fattah. Engineering and Safety Analysis of Dual-Purpose Nuclear Desalination Plants: A Case Study (Saudi Arabia). Ph.D. thesis. Iowa State University, February 1978.
2. Kazi Abdul Hasanat. Problems and Prospects of Domestic Industry Participation in Nuclear Technology Transfer. Transactions of the American Nuclear Society 25 (Supplement 1) (1977):116.
3. J. J. Fried and M. C. Edlund. Desalting Technology for Middle Eastern Agriculture, An Economic Case. Praeger Publishers, New York, 1971.
4. W. W. Siefert, M. A. Baker and M. Ali Ketani. Energy and Development, A Case Study. The MIT Press, Cambridge, Massachusetts, 1973.
5. A. F. Abdul-Fattah, A. A. Husseiny and Z. A. Sabri. Nuclear Desalination for Saudi Arabia: An Appraisal. Desalination, 1978, to be published.
6. Saudi Arabian Central Planning Organization. Saudi Arabia Five Year Plan, 1975-1980. National Technical Information Service, Publication No. PB-246 572, 1975.
7. S. Wagar A. Husaini. Principles of Environmental Engineering Systems Planning in Islamic Culture, Law, Politics, Economics, Education and Sociology of Science and Culture. Ph.D. Thesis. Department of Civil Engineering, Stanford University, December, 1971.
8. Quran 43:22.
9. S. H. Nasr. Science and Civilization in Islam. Plume Books, New York, 1968.
10. M. Jameelah. Islam and Modernism. M. Y. Khan, Sant Nagar, Lahore, Pakistan, 1966.

11. A. A. Husseiny and A. F. Abdul-Fattah. Safety Considerations of Nuclear Power Systems in Non-Nuclear and Developing Countries. Transactions of the American Nuclear Society 25 (Supplement 1) (1977):92.
12. J. Bar Anthony. A User's Guide to SAS 76. SAS Institute Inc., Raleigh, North Carolina, 1976.
13. A. A. Husseiny. A Strategy for Improving Nuclear Technology Transfer Processes Based on Experience. Transactions of the American Nuclear Society 25 (Supplement 1) (1977):108.
14. Y. Barrada. Nuclear Desalination. Elsevier, New York, 1969.
15. S. N. Bar-Zakay. Page 511 in H. F. Davidson, M. J. Cetron and J. D. Goldhar, eds. Technology Transfer, Volume 8. Noordhoff, Leiden, 1974.
16. J. A. Schumpeter. The Theory of Economic Development. Harvard University Press, Cambridge, Massachusetts, 1949.
17. National Basic Intelligence Fact Book. U.S. Government Printing Office, Washington, July 1977.
18. R. L. Kenney. A Decision Analysis with Multiple Objective: The Mexico City Airport. The Bell Journal of Economics and Management Science 4(1) (1973):101-117.
19. R. L. Kenney. Multiplicative Utility Functions. Operations Research 22(1) (1974):22-34.
20. H. Faiffa. Decision Analysis, Introductory Lectures on Choices Under Uncertainty. Addison-Wesley Publishing Company, Inc., Reading, Mass., 1970.
21. A. A. Husseiny. Nuclear Safety Analysis. (To be published)
22. R. Schlaifer. Analysis of Decisions Under Uncertainty. McGraw-Hill Company, New York, 1969.
23. R. L. Kenney. Quasi-Separable Utility Functions. Naval Research Logistics Quarterly 15(4) (1968):551.

24. Shahid Ahmed. Comparative Risk Analysis of Different Energy Sources Using Utility Theory. M.S. Thesis. Iowa State University, February 1978.
25. UNCTAD Secretariat. Guidelines for the Study of the Transfer of Technology to Developing Countries. United Nations, New York, 1972.
26. W. H. Gruber and D. G. Marquis. Introduction. Pages 3-8 in W. H. Gruber and D. G. Marquis, eds. Factors in the Transfer of Technology. The MIT Press, Cambridge, Massachusetts, 1969.
27. S. Toulmin. Innovation and Utilization. Pages 24-38 in W. H. Gruber and D. G. Marquis, eds. Factors in the Transfer of Technology. The MIT Press, Cambridge, Massachusetts, 1969.
28. Z. A. Sabri and N. A. Amherd. Advanced Nuclear Energy Systems, Retrospects and Prospects. Transactions of the American Nuclear Society 25 (Supplement 1) (1977):149.
29. K. E. El-Sheikh. A New Approach for the Efficient Probabilistic Risk Analysis of Nuclear Power Plants. Transactions of the American Nuclear Society 19 (1974):232.
30. P. Wright. Government Efforts to Facilitate Technical Transfer: The NASA Experience. Pages 238-251 in W. H. Gruber and D. G. Marquis, eds. Factors in the Transfer of Technology. The MIT Press, Cambridge, Massachusetts, 1969.
31. W. J. Price, W. G. Ashley and J. P. Martino. Science-Technology Coupling: The Experience of the Air Force Office of Scientific Research. Pages 117-136 in W. H. Gruber and D. G. Marquis, eds. Factors in the Transfer of Technology. The MIT Press, Cambridge, Massachusetts, 1969.
32. W. H. Gruber and D. G. Marquis. Research on the Human Factor in the Transfer of Technology. Pages 255-282 in Factors in the Transfer of Technology. The MIT Press, Cambridge, Massachusetts, 1969.



33. A. A. Husseiny and Z. A. Sabri. Estimation of the Diffusion of Nuclear Technology, A Probabilistic Model. To be published, 1978.
34. M. Shubik. Bibliography of Simulation, Gaming, Artificial Intelligence and Allied Topics. Journal of the American Statistical Association 55(1960): 736.
35. G. H. Orcutt, M. Greenberger, J. Korbel and A. H. Rivlin. Microanalysis of Socioeconomic Systems - A Simulation Study. Harper, New York, 1961.
36. M. Shubik. Transfer of Technology and Simulation Studies. Page 119 in D. L. Spencer and A. Worniak, eds. The Transfer of Technology to Developing Countries. Praeger, New York, 1968.
37. I. Adelman and F. L. Adelman. The Dynamic Properties of Klein-Goldberger Model. *Econometrica* 17 (1959): 596.
38. C. W. Helstrom. Markov Processes and Applications. Communication Theory. McGraw-Hill, New York, 1968.
39. E. Grossman. A Theory of the Acquisition of Speed Skill. *Ergonomics* 12 (1959):153.
40. Z. A. Sabri, A. A. Husseiny and R. A. Danofsky. An Operator Model for Reliability and Availability Evaluation of Nuclear Power Plants. Iowa State University, Engineering Research Institute Report No. ISU-ERI-Ames-76177. January 1976.
41. D. B. Wortman and S. D. Duket. Simulation Using SAINT: A User-Oriented Instruction Manual. Pritsker & Associates, Inc., Lafayette, Indiana, July 1976.
42. D. B. Wortman and S. D. Duket. The SAINT User's Manual. Pritsker & Associates, Inc., Lafayette, Indiana, July 1976.

## 9. APPENDIX A: SURVEY

## 9.1. SAS Computer Program

SAS is made up of about 70,000 source statements. About 35% of these are written in assembly language, 60% in PL/1, and the remainder in FORTRAN language. SAS is an integrated system for data management and statistical analysis. By combining statistical versatility with extensive capabilities for data manipulation and report writing, SAS gives a total system to help solve the computer problems.

SAS runs on IBM 360/370 computers under OS and VS, and requires a user region of 120K.



```

1. //E325 JOB UXXXXXX,TAWFIK
2. //STEP1 EXEC SAS
3. //SAS.SYSIN DD *
4. TITLE1 SAUDI PUBLIC SURVEY;
5. TITLE3 STATUS: G=GRADUATE STUDENTS U=UNDERGRADUATE STUDENTS;
6. TITLE4 H=HIGHSCHOOL STUDENTS O=OTHERS;
7. TITLE6 ANSWER: 1=YES 2=INDIFFERENT 3=NO 4=NO-OPINION ;
8. DATA SURVEY ;
9. INPUT STATUS $ Q1-Q39 ;
10. LABEL Q1=QUESTION1 Q2=QUESTION2 Q3=QUESTION3 Q4=QUESTION4 Q5=QUESTION5
11. Q6=QUESTION6 Q7=QUESTION7 Q8=QUESTION8 Q9=QUESTION9
12. Q10=QUESTION10 Q11=QUESTION11 Q12=QUESTION12 Q13=QUESTION13
13. Q14=QUESTION14 Q15=QUESTION15 Q16=QUESTION16 Q17=QUESTION17
14. Q18=QUESTION18 Q19=QUESTION19 Q20=QUESTION20 Q21=QUESTION21
15. Q22=QUESTION22 Q23=QUESTION23 Q24=QUESTION24 Q25=QUESTION25
16. Q26=QUESTION26 Q27=QUESTION27 Q28=QUESTION28 Q29=QUESTION29
17. Q30=QUESTION30 Q31=QUESTION31 Q32=QUESTION32 Q33=QUESTION33
18. Q34=QUESTION34 Q35=QUESTION35 Q36=QUESTION36 Q37=QUESTION37
19. Q38=QUESTION38 Q39=QUESTION39 ;
20. CARDS ;
21. H 1 1 1 1 1 2 2 2 1 3 2 3 1 1 2 4 4 4 1 1 1 3 4 1 3 4 4 4 4 4 4 4 4 2 2 1 1 1
22. U 1 2 2 3 1 2 1 1 1 2 2 2 1 1 3 1 3 3 1 1 1 1 1 3 1 2 1 3 3 3 3 3 2 3 1 1 1 1 1
23. G 2 1 1 3 1 3 1 3 3 1 2 1 2 1 1 3 3 3 2 2 2 1 2 3 1 4 4 4 4 4 4 4 4 1 1 1 1 4
24. O 2 2 1 3 3 3 1 4 3 3 1 2 3 1 3 3 1 3 3 1 3 3 3 3 1 3 1 3 1 3 3 3 3 3 3 2 2 2 3 3
25. ...
26. ...
27. ...
28. (TO THE END OF DATA CARDS. )
29. PROC FREQ ;
30. PROC FREQ ; TABLES STATUS*(Q1-Q39) Q2*Q8 Q7*Q8 Q9*Q28 Q13*Q16
31. Q13*Q17 Q13*Q19 Q13*Q21 Q13*Q25 Q13*Q31 Q13*Q34 ;
32. //

```

9.2. Questionnaire

PUBLIC ATTITUDE ASSESSMENT QUESTIONNAIRESAUDI ARABIA

Please check appropriate response:      Yes      No      Indifferent

1. Are you aware of how energy is released from nuclear fission?      \_\_\_      \_\_\_      \_\_\_

2. Do you keep up with the new developments in the nuclear energy field?      \_\_\_      \_\_\_      \_\_\_

Do you get your information about nuclear energy through:

3. Reading?      \_\_\_      \_\_\_      \_\_\_

4. Special study?      \_\_\_      \_\_\_      \_\_\_

5. Mass media?      \_\_\_      \_\_\_      \_\_\_

6. Discussion with colleagues      \_\_\_      \_\_\_      \_\_\_

7. Would you advise an acquaintance to specialize in nuclear energy?      \_\_\_      \_\_\_      \_\_\_

8. If you were given a choice to work in either an oil-fired or a nuclear power station, would you choose the nuclear power station if the salary is the same in both cases?      \_\_\_      \_\_\_      \_\_\_

If you approve of utilizing nuclear energy in Saudi Arabia, is that:

9. Because of economic benefits?      \_\_\_      \_\_\_      \_\_\_

10. To keep up with other countries?      \_\_\_      \_\_\_      \_\_\_

11. Because of scientific progress?      \_\_\_      \_\_\_      \_\_\_

	Yes	No	Indifferent
12. Because of the possible use as a weapon in time of need?	___	___	___
13. Are you familiar with how nuclear reactors operate?	___	___	___
14. Do you favor building research and power or desalination nuclear plants in Saudi Arabia at the present time?	___	___	___
<u>When is the appropriate time, from now, to introduce nuclear energy in Saudi Arabia:</u>			
15. 5 years?	___	___	___
16. 10 years?	___	___	___
17. 20 years?	___	___	___
18. More?	___	___	___
<u>If you approve of using nuclear energy in Saudi Arabia, do you prefer the construction of:</u>			
19. One large nuclear plant?	___	___	___
20. Several small plants in different regions?	___	___	___
<u>In which field do you foresee the use of nuclear energy in Saudi Arabia:</u>			
21. Electrical power?	___	___	___
22. Desalination?	___	___	___
23. Medical and agricultural radioisotope applications?	___	___	___
24. Military purposes?	___	___	___
25. All of above?	___	___	___

	Yes	No	Indifferent
<u>If you are against the peaceful uses of nuclear reactors, is that because of:</u>			
26. Fear of nuclear explosions?	___	___	___
27. Fear of radioactive release?	___	___	___
28. No urgent economical need at the present time?	___	___	___
29. Inability to operate nuclear reactors by Saudis?	___	___	___
30. Reluctance to see Saudi Arabian participation in nuclear energy projects?	___	___	___
31. The availability of oil reserves in the country?	___	___	___
32. Rejecting the use of nuclear power in general?	___	___	___
33. Fear of inability to protect Saudi Arabian nuclear energy facilities?	___	___	___
34. Worries about oppositions by nuclear countries?	___	___	___
<u>In which specific area do you foresee a potential for radioisotope applications in Saudi Arabia:</u>			
35. Medical diagnosis and therapy?	___	___	___
36. Improvement of plants breeding and crop fields?	___	___	___
37. Scientific research?	___	___	___
38. Military purposes?	___	___	___
39. All possible applications?	___	___	___



### 9.3. Results

## SAUDI PUBLIC SURVEY

STATUS: G=GRADUATE STUDENTS U=UNDERGRADUATE STUDENTS  
H=HIGHSCHOOL STUDENTS O=OTHERS

ANSWER: 1=YES 2=INDIFFERENT 3=NO 4=NO-CPINION

STATUS	FREQUENCY	CUM FREQ	PERCENT	CUM PERCENT
G	43	43	13.738	13.738
H	93	136	29.712	43.450
O	31	167	9.904	53.355
U	146	313	46.645	100.000

		QUESTION1		
Q1	FREQUENCY	CUM FREQ	PERCENT	CUM PERCENT
1	115	115	36.741	36.741
2	94	209	30.032	66.773
3	95	304	30.351	97.125
4	9	313	2.875	100.000

		QUESTION2		
Q2	FREQUENCY	CUM FREQ	PERCENT	CUM PERCENT
1	94	94	30.032	30.032
2	119	213	38.019	68.051
3	89	302	28.435	96.486
4	11	313	3.514	100.000

		QUESTION3		
Q3	FREQUENCY	CUM FREQ	PERCENT	CUM PERCENT
1	127	127	40.575	40.575
2	54	181	17.252	57.827
3	61	242	19.489	77.316
4	71	313	22.684	100.000

		QUESTION4		
Q4	FREQUENCY	CUM FREQ	PERCENT	CUM PERCENT
1	45	45	14.377	14.377
2	18	63	5.751	20.128
3	152	215	48.562	68.690
4	98	313	31.310	100.000

## SAUDI PUBLIC SURVEY

STATUS: G=GRADUATE STUDENTS U=UNDERGRADUATE STUDENTS  
H=HIGHSCHOOL STUDENTS O=OTHERS

ANSWER: 1=YES 2=INDIFFERENT 3=NO 4=NO-OPINION

QUESTION5				
Q5	FREQUENCY	CUM FREQ	PERCENT	CUM PERCENT
1	175	175	55.911	55.911
2	63	238	20.128	76.038
3	27	265	8.626	84.665
4	48	313	15.335	100.000

QUESTION6				
Q6	FREQUENCY	CUM FREQ	PERCENT	CUM PERCENT
1	56	56	17.891	17.891
2	55	111	17.572	35.463
3	100	211	31.949	67.412
4	102	313	32.588	100.000

QUESTION7				
Q7	FREQUENCY	CUM FREQ	PERCENT	CUM PERCENT
1	170	170	54.313	54.313
2	90	260	28.754	83.067
3	44	304	14.058	97.125
4	9	313	2.875	100.000

QUESTION8				
Q8	FREQUENCY	CUM FREQ	PERCENT	CUM PERCENT
1	161	161	51.438	51.438
2	50	211	15.974	67.412
3	87	298	27.796	95.208
4	15	313	4.792	100.000

QUESTION9				
Q9	FREQUENCY	CUM FREQ	PERCENT	CUM PERCENT
1	195	195	62.300	62.300
2	36	231	11.502	73.802
3	37	268	11.821	85.623
4	45	313	14.377	100.000

## SAUDI PUBLIC SURVEY

STATUS: G=GRADUATE STUDENTS U=UNDERGRADUATE STUDENTS  
H=HIGHSCHOOL STUDENTS O=CTHERS

ANSWER: 1=YES 2=INDIFFERENT 3=NO 4=NO-CPINION

QUESTION10				
Q10	FREQUENCY	CUM FREQ	PERCENT	CUM PERCENT
1	82	82	26.198	26.198
2	42	124	13.419	39.617
3	89	213	28.435	68.051
4	100	313	31.949	100.000

QUESTION11				
Q11	FREQUENCY	CUM FREQ	PERCENT	CUM PERCENT
1	149	149	47.604	47.604
2	47	196	15.016	62.620
3	34	230	10.863	73.482
4	83	313	26.518	100.000

QUESTION12				
Q12	FREQUENCY	CUM FREQ	PERCENT	CUM PERCENT
1	144	144	46.006	46.006
2	42	186	13.419	59.425
3	52	238	16.613	76.038
4	75	313	23.962	100.000

QUESTION13				
Q13	FREQUENCY	CUM FREQ	PERCENT	CUM PERCENT
1	52	52	16.613	16.613
2	106	158	33.866	50.479
3	130	288	41.534	92.013
4	25	313	7.987	100.000

QUESTION14				
Q14	FREQUENCY	CUM FREQ	PERCENT	CUM PERCENT
1	248	248	79.233	79.233
2	28	276	8.946	88.179
3	23	299	7.348	95.527
4	14	313	4.473	100.000

## SAUDI PUBLIC SURVEY

STATUS: G=GRADUATE STUDENTS U=UNDERGRADUATE STUDENTS  
H=HIGHSCHOOL STUDENTS O=OTHERS

ANSWER: 1=YES 2=INDIFFERENT 3=NO 4=NC-CPINION

QUESTION15				
Q15	FREQUENCY	CUM FREQ	PERCENT	CUM PERCENT
1	130	130	41.534	41.534
2	40	170	12.780	54.313
3	79	249	25.240	79.553
4	64	313	20.447	100.000

QUESTION16				
Q16	FREQUENCY	CUM FREQ	PERCENT	CUM PERCENT
1	93	93	29.712	29.712
2	59	152	18.850	48.562
3	54	206	17.252	65.815
4	107	313	34.185	100.000

QUESTION17				
Q17	FREQUENCY	CUM FREQ	PERCENT	CUM PERCENT
1	62	62	19.808	19.808
2	23	85	7.348	27.157
3	88	173	28.115	55.272
4	140	313	44.728	100.000

QUESTION18				
Q18	FREQUENCY	CUM FREQ	PERCENT	CUM PERCENT
1	42	42	13.419	13.419
2	18	60	5.751	19.169
3	94	154	30.032	49.201
4	159	313	50.799	100.000

QUESTION19				
Q19	FREQUENCY	CUM FREQ	PERCENT	CUM PERCENT
1	192	192	61.342	61.342
2	26	218	8.307	69.649
3	16	234	5.112	74.760
4	79	313	25.240	100.000



## SAUDI PUBLIC SURVEY

STATUS: G=GRADUATE STUDENTS U=UNDERGRADUATE STUDENTS  
H=HIGHSCHOOL STUDENTS O=OTHERS

ANSWER: 1=YES 2=INDIFFERENT 3=NO 4=NO-OPINION

QUESTION20				
Q20	FREQUENCY	CUM FREQ	PERCENT	CUM PERCENT
1	189	189	60.383	60.383
2	30	219	9.585	69.968
3	15	234	4.792	74.760
4	79	313	25.240	100.000

QUESTION21				
Q21	FREQUENCY	CUM FREQ	PERCENT	CUM PERCENT
1	182	182	58.147	58.147
2	34	216	10.863	69.010
3	20	236	6.390	75.399
4	77	313	24.601	100.000

QUESTION22				
Q22	FREQUENCY	CUM FREQ	PERCENT	CUM PERCENT
1	112	112	35.783	35.783
2	41	153	13.099	48.882
3	62	215	19.808	68.690
4	98	313	31.310	100.000

QUESTION23				
Q23	FREQUENCY	CUM FREQ	PERCENT	CUM PERCENT
1	132	132	42.173	42.173
2	42	174	13.419	55.591
3	26	200	8.307	63.898
4	113	313	36.102	100.000

QUESTION24				
Q24	FREQUENCY	CUM FREQ	PERCENT	CUM PERCENT
1	73	73	23.323	23.323
2	49	122	15.655	38.978
3	79	201	25.240	64.217
4	112	313	35.783	100.000

## SAUDI PUBLIC SURVEY

STATUS: G=GRADUATE STUDENTS U=UNDERGRADUATE STUDENTS  
H=HIGHSCHOOL STUDENTS O=OTHERS

ANSWER: 1=YES 2=INDIFFERENT 3=NO 4=NO-OPINION

QUESTION25				
Q25	FREQUENCY	CUM FREQ	PERCENT	CUM PERCENT
1	213	213	68.051	68.051
2	44	257	14.058	82.109
3	23	280	7.348	89.457
4	33	313	10.543	100.000

QUESTION26				
Q26	FREQUENCY	CUM FREQ	PERCENT	CUM PERCENT
1	63	63	20.128	20.128
2	39	102	12.460	32.588
3	74	176	23.642	56.230
4	137	313	43.770	100.000

QUESTION27				
Q27	FREQUENCY	CUM FREQ	PERCENT	CUM PERCENT
1	119	119	38.019	38.019
2	36	155	11.502	49.521
3	39	194	12.460	61.981
4	119	313	38.019	100.000

QUESTION28				
Q28	FREQUENCY	CUM FREQ	PERCENT	CUM PERCENT
1	29	29	9.265	9.265
2	25	54	7.987	17.252
3	113	167	36.102	53.355
4	146	313	46.645	100.000

QUESTION29				
Q29	FREQUENCY	CUM FREQ	PERCENT	CUM PERCENT
1	83	83	26.518	26.518
2	33	116	10.543	37.061
3	68	184	21.725	58.786
4	129	313	41.214	100.000

## SAUDI PUBLIC SURVEY

STATUS: G=GRADUATE STUDENTS U=UNDERGRADUATE STUDENTS  
H=HIGHSCHOOL STUDENTS O=OTHERS

ANSWER: 1=YES 2=INDIFFERENT 3=NO 4=NO-CPINION

QUESTION30				
Q30	FREQUENCY	CUM FREQ	PERCENT	CUM PERCENT
1	14	14	4.473	4.473
2	28	42	8.946	13.419
3	118	160	37.700	51.118
4	153	313	48.882	100.000

QUESTIGN31				
Q31	FREQUENCY	CUM FREQ	PERCENT	CUM PERCENT
1	41	41	13.099	13.099
2	39	80	12.460	25.559
3	90	170	28.754	54.313
4	143	313	45.687	100.000

QUESTION32				
Q32	FREQUENCY	CUM FREQ	PERCENT	CUM PERCENT
1	19	19	6.070	6.070
2	26	45	8.307	14.377
3	120	165	38.339	52.716
4	148	313	47.284	100.000

QUESTIGN33				
Q33	FREQUENCY	CUM FREQ	PERCENT	CUM PERCENT
1	64	64	20.447	20.447
2	43	107	13.738	34.185
3	65	172	20.767	54.952
4	141	313	45.048	100.000

QUESTION34				
Q34	FREQUENCY	CUM FREQ	PERCENT	CUM PERCENT
1	74	74	23.642	23.642
2	46	120	14.696	38.339
3	55	175	17.572	55.911
4	138	313	44.089	100.000

## SAUDI PUBLIC SURVEY

STATUS: G=GRADUATE STUDENTS U=UNDERGRADUATE STUDENTS  
H=HIGHSCHOOL STUDENTS O=OTHERS

ANSWER: 1=YES 2=INDIFFERENT 3=NO 4=NO-OPINION

QUESTION35				
Q35	FREQUENCY	CUM FREQ	PERCENT	CUM PERCENT
1	217	217	69.329	69.329
2	32	249	10.224	79.553
3	12	261	3.834	83.387
4	52	313	16.613	100.000

QUESTION36				
Q36	FREQUENCY	CUM FREQ	PERCENT	CUM PERCENT
1	184	184	58.786	58.786
2	42	226	13.419	72.204
3	19	245	6.070	78.275
4	68	313	21.725	100.000

QUESTION37				
Q37	FREQUENCY	CUM FREQ	PERCENT	CUM PERCENT
1	197	197	62.939	62.939
2	45	242	14.377	77.316
3	8	250	2.556	79.872
4	63	313	20.128	100.000

QUESTION38				
Q38	FREQUENCY	CUM FREQ	PERCENT	CUM PERCENT
1	140	140	44.728	44.728
2	46	186	14.696	59.425
3	58	244	18.530	77.955
4	69	313	22.045	100.000

QUESTION39				
Q39	FREQUENCY	CUM FREQ	PERCENT	CUM PERCENT
1	143	143	45.687	45.687
2	76	219	24.281	69.968
3	25	244	7.987	77.955
4	69	313	22.045	100.000

9.4. Analysis



## SAUDI PUBLIC SURVEY

STATUS: G=GRADUATE STUDENTS U=UNDERGRADUATE STUDENTS  
H=HIGHSCHOOL STUDENTS O=CTHERS

ANSWER: 1=YES 2=INDIFFERENT 3=NO 4=NC-CPINION

TABLE OF STATUS BY Q1

STATUS	Q1				QUESTION1	
FREQUENCY						
PERCENT						
ROW PCT						
COL PCT	1	2	3	4	TOTAL	
G	16	13	13	1	43	
	5.11	4.15	4.15	0.32	13.74	
	37.21	30.23	30.23	2.33		
	13.91	13.83	13.68	11.11		
H	36	24	31	2	93	
	11.50	7.67	9.90	0.64	29.71	
	38.71	25.81	33.33	2.15		
	31.30	25.53	32.63	22.22		
C	11	11	8	1	31	
	3.51	3.51	2.56	0.32	9.90	
	35.48	35.48	25.81	3.23		
	9.57	11.70	8.42	11.11		
U	52	46	43	5	146	
	16.61	14.70	13.74	1.60	46.65	
	35.62	31.51	29.45	3.42		
	45.22	48.94	45.26	55.56		
TOTAL	115	94	95	9	313	
	36.74	30.03	30.35	2.88	100.00	

## SAUDI PUBLIC SURVEY

STATUS: G=GRADUATE STUDENTS U=UNDERGRADUATE STUDENTS  
H=HIGHSCHOOL STUDENTS O=CTHERS

ANSWER: 1=YES 2=INDIFFERENT 3=NO 4=NO-CPINION

TABLE OF STATUS BY Q2

STATUS	Q2				QUESTION2
FREQUENCY					
PERCENT					
ROW PCT					
COL PCT	1	2	3	4	TOTAL
G	9	19	15	0	43
	2.88	6.07	4.79	0.00	13.74
	20.93	44.19	34.88	0.00	
	9.57	15.97	16.85	0.00	
H	29	26	32	6	93
	9.27	8.31	10.22	1.92	29.71
	31.18	27.96	34.41	6.45	
	30.85	21.85	35.96	54.55	
O	12	10	7	2	31
	3.83	3.19	2.24	0.64	9.90
	38.71	32.26	22.58	6.45	
	12.77	8.40	7.87	18.18	
U	44	64	35	3	146
	14.06	20.45	11.18	0.96	46.65
	30.14	43.84	23.97	2.05	
	46.81	53.78	39.33	27.27	
TOTAL	94	119	89	11	313
	30.03	38.02	28.43	3.51	100.00

## SAUDI PUBLIC SURVEY

STATUS: G=GRADUATE STUDENTS U=UNDERGRADUATE STUDENTS  
H=HIGH SCHOOL STUDENTS O=OTHERS

ANSWER: 1=YES 2=INDIFFERENT 3=NO 4=NO-OPINION

TABLE OF STATUS BY Q3

STATUS	Q3				QUESTION3	
FREQUENCY						
PERCENT						
ROW PCT						
COL PCT	1	2	3	4	TOTAL	
G	17	14	10	2	43	
	5.43	4.47	3.19	0.64	13.74	
	39.53	32.56	23.26	4.65		
	13.39	25.93	16.39	2.82		
H	39	10	21	23	93	
	12.46	3.19	6.71	7.35	29.71	
	41.94	10.75	22.58	24.73		
	30.71	18.52	34.43	32.39		
O	9	5	9	8	31	
	2.88	1.60	2.88	2.56	9.90	
	29.03	16.13	29.03	25.81		
	7.09	9.26	14.75	11.27		
U	62	25	21	38	146	
	19.81	7.99	6.71	12.14	46.65	
	42.47	17.12	14.38	26.03		
	48.82	46.30	34.43	53.52		
TOTAL	127	54	61	71	313	
	40.58	17.25	19.49	22.68	100.00	

## SAUDI PUBLIC SURVEY

STATUS: G=GRADUATE STUDENTS U=UNDERGRADUATE STUDENTS  
H=HIGHSCHOOL STUDENTS O=OTHERS

ANSWER: 1=YES 2=INDIFFERENT 3=NO 4=NO-OPINION

TABLE OF STATUS BY Q4

STATUS	Q4				QUESTION4	TOTAL
FREQUENCY	1	2	3	4		
PERCENT						
ROW PCT						
COL PCT						
G	8	4	27	4	43	
	2.56	1.28	8.63	1.28	13.74	
	18.60	9.30	62.79	9.30		
	17.78	22.22	17.76	4.08		
H	14	5	41	33	93	
	4.47	1.60	13.10	10.54	29.71	
	15.05	5.38	44.09	35.48		
	31.11	27.78	26.97	33.67		
O	3	2	15	11	31	
	0.96	0.64	4.79	3.51	9.90	
	9.68	6.45	48.39	35.48		
	6.67	11.11	9.87	11.22		
U	20	7	69	50	146	
	6.39	2.24	22.04	15.97	46.65	
	13.70	4.79	47.26	34.25		
	44.44	38.89	45.39	51.02		
TOTAL	45	18	152	98	313	
	14.38	5.75	48.56	31.31	100.00	

## SAUDI PUBLIC SURVEY

STATUS: G=GRADUATE STUDENTS U=UNDERGRADUATE STUDENTS  
H=HIGHSCHOOL STUDENTS O=OTHERS

ANSWER: 1=YES 2=INDIFFERENT 3=NO 4=NO-OPINION

TABLE OF STATUS BY Q5

STATUS	Q5 QUESTIONS				TOTAL
FREQUENCY	1	2	3	4	
PERCENT					
ROW PCT					
COL PCT					
G	25	12	2	4	43
	7.99	3.83	0.64	1.28	13.74
	58.14	27.91	4.65	9.30	
	14.29	19.05	7.41	8.33	
H	50	17	10	16	93
	15.97	5.43	3.19	5.11	29.71
	53.76	18.28	10.75	17.20	
	28.57	26.98	37.04	33.33	
O	19	3	2	7	31
	6.07	0.96	0.64	2.24	9.90
	61.29	9.68	6.45	22.58	
	10.86	4.76	7.41	14.58	
U	81	31	13	21	146
	25.88	9.90	4.15	6.71	46.65
	55.48	21.23	8.90	14.38	
	46.29	49.21	48.15	43.75	
TOTAL	175	63	27	48	313
	55.91	20.13	8.63	15.34	100.00



## SAUDI PUBLIC SURVEY

STATUS: G=GRADUATE STUDENTS U=UNDERGRADUATE STUDENTS  
H=HIGHSCHOOL STUDENTS O=OTHERS

ANSWER: 1=YES 2=INDIFFERENT 3=NO 4=NO-CPINION

TABLE OF STATUS BY Q6

STATUS	Q6 QUESTION6				TOTAL
FREQUENCY	1	2	3	4	
PERCENT					
RCW PCT					
COL PCT					
G	12	9	18	4	43
	3.83	2.88	5.75	1.28	13.74
	27.91	20.93	41.86	9.30	
	21.43	16.36	18.00	3.92	
H	20	17	26	30	93
	6.39	5.43	8.31	9.58	29.71
	21.51	18.28	27.96	32.26	
	35.71	30.91	26.00	29.41	
O	5	5	9	12	31
	1.60	1.60	2.88	3.83	9.90
	16.13	16.13	29.03	38.71	
	8.93	9.09	9.00	11.76	
U	19	24	47	56	146
	6.07	7.67	15.02	17.89	46.65
	13.01	16.44	32.19	38.36	
	33.93	43.64	47.00	54.90	
TOTAL	56	55	100	102	313
	17.89	17.57	31.95	32.59	100.00

## SAUDI PUBLIC SURVEY

STATUS: G=GRADUATE STUDENTS U=UNDERGRADUATE STUDENTS  
H=HIGHSCHOOL STUDENTS O=CTHERS

ANSWER: 1=YES 2=INDIFFERENT 3=NO 4=NO-OPINION

TABLE OF STATUS BY Q7

STATUS	Q7				QUESTION7	
FREQUENCY						
PERCENT						
ROW PCT						
COL PCT	1	2	3	4	TOTAL	
G	21	18	4	0	43	
	6.71	5.75	1.28	0.00	13.74	
	48.84	41.86	9.30	0.00		
	12.35	20.00	9.09	0.00		
H	56	23	11	3	93	
	17.89	7.35	3.51	0.96	29.71	
	60.22	24.73	11.83	3.23		
	32.94	25.56	25.00	33.33		
O	13	8	7	3	31	
	4.15	2.56	2.24	0.96	9.90	
	41.94	25.81	22.58	9.68		
	7.65	8.89	15.91	33.33		
U	80	41	22	3	146	
	25.56	13.10	7.03	0.96	46.65	
	54.79	28.08	15.07	2.05		
	47.06	45.56	50.00	33.33		
TOTAL	170	90	44	9	313	
	54.31	28.75	14.06	2.88	100.00	

## SAUDI PUBLIC SURVEY

STATUS: G=GRADUATE STUDENTS U=UNDERGRADUATE STUDENTS  
H=HIGHSCHOOL STUDENTS O=OTHERS

ANSWER: 1=YES 2=INDIFFERENT 3=NO 4=NC-CPINION

TABLE OF STATUS BY Q8

STATUS	Q8 QUESTION8				TOTAL
FREQUENCY   PERCENT   ROW PCT   COL PCT	1	2	3	4	
G	18 5.75 41.86 11.18	8 2.56 18.60 16.00	16 5.11 37.21 18.39	1 0.32 2.33 6.67	43 13.74
H	54 17.25 58.06 33.54	17 5.43 18.28 34.00	16 5.11 17.20 18.39	6 1.92 6.45 40.00	93 29.71
C	11 3.51 35.48 6.83	6 1.92 19.35 12.00	9 2.88 29.03 10.34	5 1.60 16.13 33.33	31 9.90
U	78 24.92 53.42 48.45	19 6.07 13.01 38.00	46 14.70 31.51 52.87	3 0.96 2.05 20.00	146 46.65
TOTAL	161 51.44	50 15.97	87 27.80	15 4.79	313 100.00

## SAUDI PUBLIC SURVEY

STATUS: G=GRADUATE STUDENTS U=UNDERGRADUATE STUDENTS  
H=HIGHSCHOOL STUDENTS O=OTHERS

ANSWER: 1=YES 2=INDIFFERENT 3=NO 4=NO-OPINION

TABLE OF STATUS BY Q9

STATUS	Q9				QUESTION9
FREQUENCY					
PERCENT					
ROW PCT					
COL PCT	1	2	3	4	TOTAL
G	26	5	8	4	43
	8.31	1.60	2.56	1.28	13.74
	60.47	11.63	18.60	9.30	
	13.33	13.89	21.62	8.89	
H	58	9	9	17	93
	18.53	2.88	2.88	5.43	29.71
	62.37	9.68	9.68	18.28	
	29.74	25.00	24.32	37.78	
O	19	3	5	4	31
	6.07	0.96	1.60	1.28	9.90
	61.29	9.68	16.13	12.90	
	9.74	8.33	13.51	8.89	
U	92	19	15	20	146
	29.39	6.07	4.79	6.39	46.65
	63.01	13.01	10.27	13.70	
	47.18	52.78	40.54	44.44	
TOTAL	195	36	37	45	313
	62.30	11.50	11.82	14.38	100.00

## SAUDI PUBLIC SURVEY

STATUS: G=GRADUATE STUDENTS U=UNDERGRADUATE STUDENTS  
H=HIGH SCHOOL STUDENTS O=OTHERS

ANSWER: 1=YES 2=INDIFFERENT 3=NO 4=NO-OPINION

TABLE OF STATUS BY Q10

STATUS	Q10 QUESTION10				TOTAL
FREQUENCY   PERCENT   ROW PCT   COL PCT	1	2	3	4	
G	13 4.15 30.23 15.85	6 1.92 13.95 14.29	19 6.07 44.19 21.35	5 1.60 11.63 5.00	43 13.74
H	26 8.31 27.96 31.71	11 3.51 11.83 26.19	19 6.07 20.43 21.35	37 11.82 39.78 37.00	93 29.71
O	5 1.60 16.13 6.10	5 1.60 16.13 11.90	8 2.56 25.81 8.99	13 4.15 41.94 13.00	31 9.90
U	38 12.14 26.03 46.34	20 6.39 13.70 47.62	43 13.74 29.45 48.31	45 14.38 30.82 45.00	146 46.65
TOTAL	82 26.20	42 13.42	89 28.43	100 31.95	313 100.00



## SAUDI PUBLIC SURVEY

STATUS: G=GRADUATE STUDENTS U=UNDERGRADUATE STUDENTS  
H=HIGHSCHOOL STUDENTS O=OTHERS

ANSWER: 1=YES 2=INDIFFERENT 3=NO 4=NC-CPINICN

TABLE OF STATUS BY Q11

STATUS	Q11 QUESTION11				
FREQUENCY					
PERCENT					
ROW PCT					
COL PCT	1	2	3	4	TOTAL
G	22	9	8	4	43
	7.03	2.88	2.56	1.28	13.74
	51.16	20.93	18.60	9.30	
	14.77	19.15	23.53	4.82	
H	41	12	9	31	93
	13.10	3.83	2.88	9.90	29.71
	44.09	12.90	9.68	33.33	
	27.52	25.53	26.47	37.35	
O	10	7	3	11	31
	3.19	2.24	0.96	3.51	9.90
	32.26	22.58	9.68	35.48	
	6.71	14.89	8.82	13.25	
U	76	19	14	37	146
	24.28	6.07	4.47	11.82	46.65
	52.05	13.01	9.59	25.34	
	51.01	40.43	41.18	44.58	
TOTAL	149	47	34	83	313
	47.60	15.02	10.86	26.52	100.00

## SAUDI PUBLIC SURVEY

STATUS: G=GRADUATE STUDENTS U=UNDERGRADUATE STUDENTS  
H=HIGH SCHOOL STUDENTS O=OTHERS

ANSWER: 1=YES 2=INDIFFERENT 3=NO 4=NO-OPINION

TABLE OF STATUS BY Q12

STATUS	Q12				QUESTION12	TOTAL
FREQUENCY	1	2	3	4		
PERCENT						
ROW PCT						
COL PCT						
G	20	10	9	4	43	
	6.39	3.19	2.88	1.28	13.74	
	46.51	23.26	20.93	9.30		
	13.89	23.81	17.31	5.33		
H	38	12	14	29	93	
	12.14	3.83	4.47	9.27	29.71	
	40.86	12.90	15.05	31.18		
	26.39	28.57	26.92	38.67		
O	12	4	6	9	31	
	3.83	1.28	1.92	2.88	9.90	
	38.71	12.90	19.35	29.03		
	8.33	9.52	11.54	12.00		
U	74	16	23	33	146	
	23.64	5.11	7.35	10.54	46.65	
	50.68	10.96	15.75	22.60		
	51.39	38.10	44.23	44.00		
TOTAL	144	42	52	75	313	
	46.01	13.42	16.61	23.96	100.00	

## SAUDI PUBLIC SURVEY

STATUS: G=GRADUATE STUDENTS U=UNDERGRADUATE STUDENTS  
H=HIGHSCHOOL STUDENTS O=OTHERS

ANSWER: 1=YES 2=INDIFFERENT 3=NO 4=NO-CPINION

TABLE OF STATUS BY Q13

STATUS	Q13 QUESTION13				
FREQUENCY	1	2	3	4	TOTAL
PERCENT					
ROW PCT					
COL PCT					
G	6	21	16	0	43
	1.92	6.71	5.11	0.00	13.74
	13.95	48.84	37.21	0.00	
	11.54	19.81	12.31	0.00	
H	16	25	45	7	93
	5.11	7.99	14.38	2.24	29.71
	17.20	26.88	48.39	7.53	
	30.77	23.58	34.62	28.00	
O	5	9	14	3	31
	1.60	2.88	4.47	0.96	9.90
	16.13	29.03	45.16	9.68	
	9.62	8.49	10.77	12.00	
U	25	51	55	15	146
	7.99	16.29	17.57	4.79	46.65
	17.12	34.93	37.67	10.27	
	48.08	48.11	42.31	60.00	
TOTAL	52	106	130	25	313
	16.61	33.87	41.53	7.99	100.00

## SAUDI PUBLIC SURVEY

STATUS: G=GRADUATE STUDENTS U=UNDERGRADUATE STUDENTS  
H=HIGHSCHOOL STUDENTS O=OTHERS

ANSWER: 1=YES 2=INDIFFERENT 3=NO 4=NC-OFINION

TABLE OF STATUS BY Q14

STATUS	Q14 QUESTION14				TOTAL
FREQUENCY	1	2	3	4	
PERCENT					
ROW PCT					
CGL PCT					
G	33	5	4	1	43
	10.54	1.60	1.28	0.32	13.74
	76.74	11.63	9.30	2.33	
	13.31	17.86	17.39	7.14	
H	72	8	6	7	93
	23.00	2.56	1.92	2.24	29.71
	77.42	8.60	6.45	7.53	
	29.03	28.57	26.09	50.00	
O	23	4	2	2	31
	7.35	1.28	0.64	0.64	9.90
	74.19	12.90	6.45	6.45	
	9.27	14.29	8.70	14.29	
U	120	11	11	4	146
	38.34	3.51	3.51	1.28	46.65
	82.19	7.53	7.53	2.74	
	48.39	39.29	47.83	28.57	
TOTAL	248	28	23	14	313
	79.23	8.95	7.35	4.47	100.00

## SAUDI PUBLIC SURVEY

STATUS: G=GRADUATE STUDENTS U=UNDERGRADUATE STUDENTS  
H=HIGHSCHOOL STUDENTS O=OTHERS

ANSWER: 1=YES 2=INDIFFERENT 3=NO 4=NO-OPINION

TABLE OF STATUS BY Q15

STATUS	Q15				QUESTION15
FREQUENCY					
PERCENT					
ROW PCT					
COL PCT	1	2	3	4	TOTAL
G	13	8	18	4	43
	4.15	2.56	5.75	1.28	13.74
	30.23	18.60	41.86	9.30	
	10.00	20.00	22.78	6.25	
H	42	15	16	20	93
	13.42	4.79	5.11	6.39	29.71
	45.16	16.13	17.20	21.51	
	32.31	37.50	20.25	31.25	
O	13	5	6	7	31
	4.15	1.60	1.92	2.24	9.90
	41.94	16.13	19.35	22.58	
	10.00	12.50	7.59	10.94	
U	62	12	39	33	146
	19.81	3.83	12.46	10.54	46.65
	42.47	8.22	26.71	22.60	
	47.69	30.00	49.37	51.56	
TOTAL	130	40	79	64	313
	41.53	12.78	25.24	20.45	100.00



## SAUDI PUBLIC SURVEY

STATUS: G=GRADUATE STUDENTS U=UNDERGRADUATE STUDENTS  
H=HIGHSCHOOL STUDENTS O=CTHERS

ANSWER: 1=YES 2=INDIFFERENT 3=NO 4=NO-CPINION

TABLE OF STATUS BY Q16

STATUS	Q16 QUESTION16				
FREQUENCY					
PERCENT					
ROW PCT					
COL PCT	1	2	3	4	TOTAL
G	12	11	14	6	43
	3.83	3.51	4.47	1.92	13.74
	27.91	25.58	32.56	13.95	
	12.90	18.64	25.93	5.61	
H	27	17	11	38	93
	8.63	5.43	3.51	12.14	29.71
	29.03	18.28	11.83	40.86	
	29.03	28.81	20.37	35.51	
O	7	7	3	14	31
	2.24	2.24	0.96	4.47	9.90
	22.58	22.58	9.68	45.16	
	7.53	11.86	5.56	13.08	
U	47	24	26	49	146
	15.02	7.67	8.31	15.65	46.65
	32.19	16.44	17.81	33.56	
	50.54	40.68	48.15	45.79	
TOTAL	93	59	54	107	313
	29.71	18.85	17.25	34.19	100.00

## SAUDI PUBLIC SURVEY

STATUS: G=GRADUATE STUDENTS U=UNDERGRADUATE STUDENTS  
H=HIGH SCHOOL STUDENTS O=OTHERS

ANSWER: 1=YES 2=INDIFFERENT 3=NO 4=NO-OPINION

TABLE OF STATUS BY Q17

STATUS	Q17				QUESTION17
FREQUENCY					
PERCENT					
ROW PCT					
COL PCT	1	2	3	4	TOTAL
G	14	2	14	13	43
	4.47	0.64	4.47	4.15	13.74
	32.56	4.65	32.56	30.23	
	22.58	8.70	15.91	9.29	
H	16	5	27	45	93
	5.11	1.60	8.63	14.38	29.71
	17.20	5.38	29.03	48.39	
	25.81	21.74	30.68	32.14	
O	5	5	6	15	31
	1.60	1.60	1.92	4.79	9.90
	16.13	16.13	19.35	48.39	
	8.06	21.74	6.82	10.71	
U	27	11	41	67	146
	8.63	3.51	13.10	21.41	46.65
	18.49	7.53	28.08	45.89	
	43.55	47.83	46.59	47.86	
TOTAL	62	23	88	140	313
	19.81	7.35	28.12	44.73	100.00

## SAUDI PUBLIC SURVEY

STATUS: G=GRADUATE STUDENTS U=UNDERGRADUATE STUDENTS  
H=HIGHSCHOOL STUDENTS O=CTHERS

ANSWER: 1=YES 2=INDIFFERENT 3=NO 4=NO-CPINION

TABLE OF STATUS BY Q18

STATUS	Q18 QUESTION18				
FREQUENCY	1	2	3	4	TOTAL
PERCENT					
ROW PCT					
CCL PCT					
G	5	3	19	16	43
	1.60	0.96	6.07	5.11	13.74
	11.63	6.98	44.19	37.21	
	11.90	16.67	20.21	10.06	
H	16	7	25	45	93
	5.11	2.24	7.99	14.38	29.71
	17.20	7.53	26.88	48.39	
	38.10	38.89	26.60	28.30	
O	2	3	8	18	31
	0.64	0.96	2.56	5.75	9.90
	6.45	9.68	25.81	58.06	
	4.76	16.67	8.51	11.32	
U	19	5	42	80	146
	6.07	1.60	13.42	25.56	46.65
	13.01	3.42	28.77	54.79	
	45.24	27.78	44.68	50.31	
TOTAL	42	18	94	159	313
	13.42	5.75	30.03	50.80	100.00

## SAUDI PUBLIC SURVEY

STATUS: G=GRADUATE STUDENTS U=UNDERGRADUATE STUDENTS  
H=HIGHSCHOOL STUDENTS O=CTHERS

ANSWER: 1=YES 2=INDIFFERENT 3=NO 4=NC-CPINION

TABLE OF STATUS BY Q19

STATUS	Q19 QUESTION19				
FREQUENCY					
PERCENT					
ROW PCT					
COL PCT	1	2	3	4	TOTAL
G	28	7	2	6	43
	8.95	2.24	0.64	1.92	13.74
	65.12	16.28	4.65	13.95	
	14.58	26.92	12.50	7.59	
H	53	10	5	25	93
	16.93	3.19	1.60	7.99	29.71
	56.99	10.75	5.38	26.88	
	27.60	38.46	31.25	31.65	
O	10	3	1	17	31
	3.19	0.96	0.32	5.43	9.90
	32.26	9.68	3.23	54.84	
	5.21	11.54	6.25	21.52	
U	101	6	8	31	146
	32.27	1.92	2.56	9.90	46.65
	69.18	4.11	5.48	21.23	
	52.60	23.08	50.00	39.24	
TOTAL	192	26	16	79	313
	61.34	8.31	5.11	25.24	100.00

## SAUDI PUBLIC SURVEY

STATUS: G=GRADUATE STUDENTS U=UNDERGRADUATE STUDENTS  
H=HIGHSCHOOL STUDENTS O=CTHERS

ANSWER: 1=YES 2=INDIFFERENT 3=NO 4=NO-CPINION

TABLE OF STATUS BY Q20

STATUS	Q20				QUESTION20	TOTAL
FREQUENCY	1	2	3	4		
PERCENT						
RGW PCT						
COL PCT						
G	29	6	2	6	43	
	9.27	1.92	0.64	1.92	13.74	
	67.44	13.95	4.65	13.95		
	15.34	20.00	13.33	7.59		
H	53	8	5	27	93	
	16.93	2.56	1.60	8.63	29.71	
	56.99	8.60	5.38	29.03		
	28.04	26.67	33.33	34.18		
O	10	5	1	15	31	
	3.19	1.60	0.32	4.79	9.90	
	32.26	16.13	3.23	48.39		
	5.29	16.67	6.67	18.99		
U	97	11	7	31	146	
	30.99	3.51	2.24	9.90	46.65	
	66.44	7.53	4.79	21.23		
	51.32	36.67	46.67	39.24		
TOTAL	189	30	15	79	313	
	60.38	9.58	4.79	25.24	100.00	



## SAUDI PUBLIC SURVEY

STATUS: G=GRADUATE STUDENTS U=UNDERGRADUATE STUDENTS  
H=HIGHSCHOOL STUDENTS O=OTHERS

ANSWER: 1=YES 2=INDIFFERENT 3=NO 4=NC-CPINION

TABLE OF STATUS BY Q21

STATUS	Q21 QUESTION21				
FREQUENCY					
PERCENT					
ROW PCT					
COL PCT	1	2	3	4	TOTAL
G	25	6	5	7	43
	7.99	1.92	1.60	2.24	13.74
	58.14	13.95	11.63	16.28	
	13.74	17.65	25.00	9.09	
H	49	11	5	28	93
	15.65	3.51	1.60	8.95	29.71
	52.69	11.83	5.38	30.11	
	26.92	32.35	25.00	36.36	
O	13	6	0	12	31
	4.15	1.92	0.00	3.83	9.90
	41.94	19.35	0.00	38.71	
	7.14	17.65	0.00	15.58	
U	95	11	10	30	146
	30.35	3.51	3.19	9.58	46.65
	65.07	7.53	6.85	20.55	
	52.20	32.35	50.00	38.96	
TOTAL	182	34	20	77	313
	58.15	10.86	6.39	24.60	100.00

## SAUDI PUBLIC SURVEY

STATUS: G=GRADUATE STUDENTS U=UNDERGRADUATE STUDENTS  
H=HIGHSCHOOL STUDENTS O=CTHERS

ANSWER: 1=YES 2=INDIFFERENT 3=NO 4=NO-OPINION

TABLE OF STATUS BY Q22

STATUS	Q22				QUESTION22
FREQUENCY					
PERCENT					
ROW PCT					
COL PCT	1	2	3	4	TOTAL
G	16	12	8	7	43
	5.11	3.83	2.56	2.24	13.74
	37.21	27.91	18.60	16.28	
	14.29	29.27	12.90	7.14	
H	32	12	15	34	93
	10.22	3.83	4.79	10.86	29.71
	34.41	12.90	16.13	36.56	
	28.57	29.27	24.19	34.69	
O	5	2	8	16	31
	1.60	0.64	2.56	5.11	9.90
	16.13	6.45	25.81	51.61	
	4.46	4.88	12.90	16.33	
U	59	15	31	41	146
	18.85	4.79	9.90	13.10	46.65
	40.41	10.27	21.23	28.08	
	52.68	36.59	50.00	41.84	
TOTAL	112	41	62	98	313
	35.78	13.10	19.81	31.31	100.00

## SAUDI PUBLIC SURVEY

STATUS: G=GRADUATE STUDENTS U=UNDERGRADUATE STUDENTS  
H=HIGHSCHOOL STUDENTS C=OTHERS

ANSWER: 1=YES 2=INDIFFERENT 3=NO 4=NO-OPINION

TABLE OF STATUS BY Q23

STATUS	Q23				QUESTION23
FREQUENCY					
PERCENT					
ROW PCT					
CGL PCT	1	2	3	4	TOTAL
G	16	9	5	13	43
	5.11	2.88	1.60	4.15	13.74
	37.21	20.93	11.63	30.23	
	12.12	21.43	19.23	11.50	
H	35	18	7	33	93
	11.18	5.75	2.24	10.54	29.71
	37.63	19.35	7.53	35.48	
	26.52	42.86	26.92	29.20	
C	15	5	4	7	31
	4.79	1.60	1.28	2.24	9.90
	48.39	16.13	12.90	22.58	
	11.36	11.90	15.38	6.19	
U	66	10	10	60	146
	21.09	3.19	3.19	19.17	46.65
	45.21	6.85	6.85	41.10	
	50.00	23.81	38.46	53.10	
TOTAL	132	42	26	113	313
	42.17	13.42	8.31	36.10	100.00

## SAUDI PUBLIC SURVEY

STATUS: G=GRADUATE STUDENTS U=UNDERGRADUATE STUDENTS  
H=HIGHSCHOOL STUDENTS O=OTHERS

ANSWER: 1=YES 2=INDIFFERENT 3=NO 4=NO-CPINION

TABLE OF STATUS BY Q24

STATUS	Q24				QUESTION24
FREQUENCY					
PERCENT					
ROW PCT					
COL PCT	1	2	3	4	TOTAL
G	13	5	18	7	43
	4.15	1.60	5.75	2.24	13.74
	30.23	11.63	41.86	16.28	
	17.81	10.20	22.78	6.25	
H	22	15	19	37	93
	7.03	4.79	6.07	11.82	29.71
	23.66	16.13	20.43	39.78	
	30.14	30.61	24.05	33.04	
O	5	7	5	14	31
	1.60	2.24	1.60	4.47	9.90
	16.13	22.58	16.13	45.16	
	6.85	14.29	6.33	12.50	
U	33	22	37	54	146
	10.54	7.03	11.82	17.25	46.65
	22.60	15.07	25.34	36.99	
	45.21	44.90	46.84	48.21	
TOTAL	73	49	79	112	313
	23.32	15.65	25.24	35.78	100.00

## SAUDI PUBLIC SURVEY

STATUS: G=GRADUATE STUDENTS U=UNDERGRADUATE STUDENTS  
H=HIGHSCHOOL STUDENTS O=CTHERS

ANSWER: 1=YES 2=INDIFFERENT 3=NO 4=NO-OPINION

TABLE OF STATUS BY Q25

STATUS	Q25				QUESTION25
FREQUENCY					
PERCENT					
ROW PCT					
COL PCT	1	2	3	4	TOTAL
G	29	9	2	3	43
	9.27	2.88	0.64	0.96	13.74
	67.44	20.93	4.65	6.98	
	13.62	20.45	8.70	9.09	
H	65	15	5	8	93
	20.77	4.79	1.60	2.56	29.71
	69.89	16.13	5.38	8.60	
	30.52	34.09	21.74	24.24	
O	18	3	3	7	31
	5.75	0.96	0.96	2.24	9.90
	58.06	9.68	9.68	22.58	
	8.45	6.82	13.04	21.21	
U	101	17	13	15	146
	32.27	5.43	4.15	4.79	46.65
	69.18	11.64	8.90	10.27	
	47.42	38.64	56.52	45.45	
TOTAL	213	44	23	33	313
	68.05	14.06	7.35	10.54	100.00



## SAUDI PUBLIC SURVEY

STATUS: G=GRADUATE STUDENTS U=UNDERGRADUATE STUDENTS  
H=HIGHSCHOOL STUDENTS O=OTHERS

ANSWER: 1=YES 2=INDIFFERENT 3=NO 4=NC-CPINION

TABLE OF STATUS BY Q26

STATUS	Q26 QUESTION26				TOTAL
FREQUENCY	1	2	3	4	
PERCENT					
ROW PCT					
COL PCT					
G	10	8	13	12	43
	3.19	2.56	4.15	3.83	13.74
	23.26	18.60	30.23	27.91	
	15.87	20.51	17.57	8.76	
H	19	10	18	46	93
	6.07	3.19	5.75	14.70	29.71
	20.43	10.75	19.35	49.46	
	30.16	25.64	24.32	33.58	
O	5	4	5	17	31
	1.60	1.28	1.60	5.43	9.90
	16.13	12.90	16.13	54.84	
	7.94	10.26	6.76	12.41	
U	29	17	38	62	146
	9.27	5.43	12.14	19.81	46.65
	19.86	11.64	26.03	42.47	
	46.03	43.59	51.35	45.26	
TOTAL	63	39	74	137	313
	20.13	12.46	23.64	43.77	100.00

## SAUDI PUBLIC SURVEY

STATUS: G=GRADUATE STUDENTS U=UNDERGRADUATE STUDENTS  
H=HIGHSCHOOL STUDENTS O=OTHERS

ANSWER: 1=YES 2=INDIFFERENT 3=NO 4=NO-OPINION

TABLE OF STATUS BY Q27

STATUS	Q27 QUESTION27				
FREQUENCY					
PERCENT					
ROW PCT					
COL PCT	1	2	3	4	TOTAL
G	17	7	10	9	43
	5.43	2.24	3.19	2.88	13.74
	39.53	16.28	23.26	20.93	
	14.29	19.44	25.64	7.56	
H	32	12	9	40	93
	10.22	3.83	2.88	12.78	29.71
	34.41	12.90	9.68	43.01	
	26.89	33.33	23.08	33.61	
O	12	4	2	13	31
	3.83	1.28	0.64	4.15	9.90
	38.71	12.90	6.45	41.94	
	10.08	11.11	5.13	10.92	
U	58	13	18	57	146
	18.53	4.15	5.75	18.21	46.65
	39.73	8.90	12.33	39.04	
	48.74	36.11	46.15	47.90	
TOTAL	119	36	39	119	313
	38.02	11.50	12.46	38.02	100.00

## SAUDI PUBLIC SURVEY

STATUS: G=GRADUATE STUDENTS U=UNDERGRADUATE STUDENTS  
H=HIGHSCHOOL STUDENTS O=OTHERS

ANSWER: 1=YES 2=INDIFFERENT 3=NO 4=NC-OPINION

TABLE OF STATUS BY Q28

STATUS	Q28 QUESTION28				
FREQUENCY					
PERCENT					
ROW PCT					
COL PCT	1	2	3	4	TOTAL
G	6	5	22	10	43
	1.92	1.60	7.03	3.19	13.74
	13.95	11.63	51.16	23.26	
	20.69	20.00	19.47	6.85	
H	8	8	30	47	93
	2.56	2.56	9.58	15.02	29.71
	8.60	8.60	32.26	50.54	
	27.59	32.00	26.55	32.19	
O	3	2	10	16	31
	0.96	0.64	3.19	5.11	9.90
	9.68	6.45	32.26	51.61	
	10.34	8.00	8.85	10.96	
U	12	10	51	73	146
	3.83	3.19	16.29	23.32	46.65
	8.22	6.85	34.93	50.00	
	41.38	40.00	45.13	50.00	
TOTAL	29	25	113	146	313
	9.27	7.99	36.10	46.65	100.00

## SAUDI PUBLIC SURVEY

STATUS: G=GRADUATE STUDENTS U=UNDERGRADUATE STUDENTS  
H=HIGHSCHOOL STUDENTS O=CTHERS

ANSWER: 1=YES 2=INDIFFERENT 3=NO 4=NC-CFINION

TABLE OF STATUS BY Q29

STATUS	Q29 QUESTION29				TOTAL
FREQUENCY	1	2	3	4	
PERCENT					
ROW PCT					
CGL PCT					
G	17	6	12	8	43
	5.43	1.92	3.83	2.56	13.74
	39.53	13.95	27.91	18.60	
	20.48	18.18	17.65	6.20	
H	14	11	22	46	93
	4.47	3.51	7.03	14.70	29.71
	15.05	11.83	23.66	49.46	
	16.87	33.33	32.35	35.66	
C	7	3	6	15	31
	2.24	0.96	1.92	4.79	9.90
	22.58	9.68	19.35	48.39	
	8.43	9.09	8.82	11.63	
U	45	13	28	60	146
	14.38	4.15	8.95	19.17	46.65
	30.82	8.90	19.18	41.10	
	54.22	39.39	41.18	46.51	
TOTAL	83	33	68	129	313
	26.52	10.54	21.73	41.21	100.00

## SAUDI PUBLIC SURVEY

STATUS: G=GRADUATE STUDENTS U=UNDERGRADUATE STUDENTS  
H=HIGHSCHOOL STUDENTS O=OTHERS

ANSWER: 1=YES 2=INDIFFERENT 3=NO 4=NO-OPINION

TABLE OF STATUS BY Q30

STATUS	Q30 QUESTION30				TOTAL
FREQUENCY   PERCENT   RGW PCT   COL PCT	1	2	3	4	
G	4 1.28 9.30 28.57	3 0.96 6.98 10.71	25 7.99 58.14 21.19	11 3.51 25.58 7.19	43 13.74
H	2 0.64 2.15 14.29	7 2.24 7.53 25.00	32 10.22 34.41 27.12	52 16.61 55.91 33.99	93 29.71
O	1 0.32 3.23 7.14	4 1.28 12.90 14.29	10 3.19 32.26 8.47	16 5.11 51.61 10.46	31 9.90
U	7 2.24 4.79 50.00	14 4.47 9.59 50.00	51 16.29 34.93 43.22	74 23.64 50.68 48.37	146 46.65
TOTAL	14 4.47	28 8.95	118 37.70	153 48.88	313 100.00



## SAUDI PUBLIC SURVEY

STATUS: G=GRADUATE STUDENTS U=UNDERGRADUATE STUDENTS  
H=HIGHSCHOOL STUDENTS O=OTHERS

ANSWER: 1=YES 2=INDIFFERENT 3=NO 4=NC-OPINION

TABLE OF STATUS BY Q31

STATUS	Q31				QUESTION31
FREQUENCY					
PERCENT					
ROW PCT					
CCL PCT	1	2	3	4	TOTAL
G	4	8	20	11	43
	1.28	2.56	6.39	3.51	13.74
	9.30	18.60	46.51	25.58	
	9.76	20.51	22.22	7.69	
H	12	10	23	48	93
	3.83	3.19	7.35	15.34	29.71
	12.90	10.75	24.73	51.61	
	29.27	25.64	25.56	33.57	
O	3	5	7	16	31
	0.96	1.60	2.24	5.11	9.90
	9.68	16.13	22.58	51.61	
	7.32	12.82	7.78	11.19	
U	22	16	40	68	146
	7.03	5.11	12.78	21.73	46.65
	15.07	10.96	27.40	46.58	
	53.66	41.03	44.44	47.55	
TOTAL	41	39	90	143	313
	13.10	12.46	28.75	45.69	100.00

## SAUDI PUBLIC SURVEY

STATUS: G=GRADUATE STUDENTS U=UNDERGRADUATE STUDENTS  
H=HIGHSCHOOL STUDENTS O=OTHERS

ANSWER: 1=YES 2=INDIFFERENT 3=NO 4=NO-CPINION

TABLE OF STATUS BY Q32

STATUS	Q32				QUESTION32
FREQUENCY					
PERCENT					
ROW PCT					
CGL PCT	1	2	3	4	TOTAL
G	3	2	28	10	43
	0.96	0.64	8.95	3.19	13.74
	6.98	4.65	65.12	23.26	
	15.79	7.69	23.33	6.76	
H	3	12	26	52	93
	0.96	3.83	8.31	16.61	29.71
	3.23	12.90	27.96	55.91	
	15.79	46.15	21.67	35.14	
O	3	3	8	17	31
	0.96	0.96	2.56	5.43	9.90
	9.68	9.68	25.81	54.84	
	15.79	11.54	6.67	11.49	
U	10	9	58	69	146
	3.19	2.88	18.53	22.04	46.65
	6.85	6.16	39.73	47.26	
	52.63	34.62	48.33	46.62	
TOTAL	19	26	120	148	313
	6.07	8.31	38.34	47.28	100.00

## SAUDI PUBLIC SURVEY

STATUS: G=GRADUATE STUDENTS U=UNDERGRADUATE STUDENTS  
 H=HIGH SCHOOL STUDENTS O=OTHERS

ANSWER: 1=YES 2=INDIFFERENT 3=NO 4=NO-OPINION

TABLE OF STATUS BY Q33

STATUS	Q33				QUESTION33
FREQUENCY					
PERCENT					
ROW PCT					
COL PCT	1	2	3	4	TOTAL
G	7	12	13	11	43
	2.24	3.83	4.15	3.51	13.74
	16.28	27.91	30.23	25.58	
	10.94	27.91	20.00	7.80	
H	12	10	19	52	93
	3.83	3.19	6.07	16.61	29.71
	12.90	10.75	20.43	55.91	
	18.75	23.26	29.23	36.88	
C	9	5	5	12	31
	2.88	1.60	1.60	3.83	9.90
	29.03	16.13	16.13	38.71	
	14.06	11.63	7.69	8.51	
U	36	16	28	66	146
	11.50	5.11	8.95	21.09	46.65
	24.66	10.96	19.18	45.21	
	56.25	37.21	43.08	46.81	
TOTAL	64	43	65	141	313
	20.45	13.74	20.77	45.05	100.00

## SAUDI PUBLIC SURVEY

STATUS: G=GRADUATE STUDENTS U=UNDERGRADUATE STUDENTS  
 H=HIGHSCHOOL STUDENTS O=OTHERS

ANSWER: 1=YES 2=INDIFFERENT 3=NO 4=NO-OPINION

TABLE OF STATUS BY Q34

STATUS	Q34				QUESTION34
FREQUENCY					
PERCENT					
ROW PCT					
COL PCT	1	2	3	4	TOTAL
G	4	13	14	12	43
	1.28	4.15	4.47	3.83	13.74
	9.30	30.23	32.56	27.91	
	5.41	28.26	25.45	8.70	
H	22	11	14	46	93
	7.03	3.51	4.47	14.70	29.71
	23.66	11.83	15.05	49.46	
	29.73	23.91	25.45	33.33	
O	7	5	6	13	31
	2.24	1.60	1.92	4.15	9.90
	22.58	16.13	19.35	41.94	
	9.46	10.87	10.91	9.42	
U	41	17	21	67	146
	13.10	5.43	6.71	21.41	46.65
	28.08	11.64	14.38	45.89	
	55.41	36.96	38.18	48.55	
TOTAL	74	46	55	138	313
	23.64	14.70	17.57	44.09	100.00

## SAUDI PUBLIC SURVEY

STATUS: G=GRADUATE STUDENTS U=UNDERGRADUATE STUDENTS  
H=HIGHSCHOOL STUDENTS O=OTHERS

ANSWER: 1=YES 2=INDIFFERENT 3=NO 4=NO-OPINION

TABLE OF STATUS BY Q35

STATUS	Q35 QUESTION35				TOTAL
FREQUENCY   PERCENT   ROW PCT   COL PCT	1	2	3	4	
G	31 9.90 72.09 14.29	6 1.92 13.95 18.75	1 0.32 2.33 8.33	5 1.60 11.63 9.62	43 13.74
H	65 20.77 69.89 29.95	10 3.19 10.75 31.25	4 1.28 4.30 33.33	14 4.47 15.05 26.92	93 29.71
O	14 4.47 45.16 6.45	3 0.96 9.68 9.38	2 0.64 6.45 16.67	12 3.83 38.71 23.08	31 9.90
U	107 34.19 73.29 49.31	15 4.15 8.90 40.63	5 1.60 3.42 41.67	21 6.71 14.38 40.38	146 46.65
TOTAL	217 69.33	32 10.22	12 3.83	52 16.61	313 100.00



## SAUDI PUBLIC SURVEY

STATUS: G=GRADUATE STUDENTS U=UNDERGRADUATE STUDENTS  
H=HIGH SCHOOL STUDENTS O=OTHERS

ANSWER: 1=YES 2=INDIFFERENT 3=NO 4=NO-OPINION

TABLE OF STATUS BY Q36

STATUS	Q36 QUESTION36				TOTAL
FREQUENCY	1	2	3	4	
PERCENT					
ROW PCT					
COL PCT					
G	28	7	4	4	43
	8.95	2.24	1.28	1.28	13.74
	65.12	16.28	9.30	9.30	
	15.22	16.67	21.05	5.88	
H	53	13	7	20	93
	16.93	4.15	2.24	6.39	29.71
	56.99	13.98	7.53	21.51	
	28.80	30.95	36.84	29.41	
O	10	4	3	14	31
	3.19	1.28	0.96	4.47	9.90
	32.26	12.90	9.68	45.16	
	5.43	9.52	15.79	20.55	
U	93	18	5	30	146
	29.71	5.75	1.60	9.58	46.65
	63.70	12.33	3.42	20.55	
	50.54	42.86	26.32	44.12	
TOTAL	184	42	19	68	313
	58.79	13.42	6.07	21.73	100.00

## SAUDI PUBLIC SURVEY

STATUS: G=GRADUATE STUDENTS U=UNDERGRADUATE STUDENTS  
H=HIGH SCHOOL STUDENTS O=OTHERS

ANSWER: 1=YES 2=INDIFFERENT 3=NO 4=NO-OPINION

TABLE OF STATUS BY Q37

STATUS	Q37				QUESTION37
FREQUENCY					
PERCENT					
ROW PCT					
COL PCT	1	2	3	4	TOTAL
G	29	9	1	4	43
	9.27	2.88	0.32	1.28	13.74
	67.44	20.93	2.33	9.30	
	14.72	20.00	12.50	6.35	
H	59	14	1	19	93
	18.85	4.47	0.32	6.07	29.71
	63.44	15.05	1.08	20.43	
	29.95	31.11	12.50	30.16	
O	11	6	2	12	31
	3.51	1.92	0.64	3.83	9.90
	35.48	19.35	6.45	38.71	
	5.58	13.33	25.00	19.05	
U	98	16	4	28	146
	31.31	5.11	1.28	8.95	46.65
	67.12	10.96	2.74	19.18	
	49.75	35.56	50.00	44.44	
TOTAL	197	45	8	63	313
	62.94	14.38	2.56	20.13	100.00

## SAUDI PUBLIC SURVEY

STATUS: G=GRADUATE STUDENTS U=UNDERGRADUATE STUDENTS  
H=HIGHSCHOOL STUDENTS O=CTHERS

ANSWER: 1=YES 2=INDIFFERENT 3=NO 4=NO-OPINION

TABLE OF STATUS BY Q38

STATUS	Q38				QUESTION38
FREQUENCY	1	2	3	4	TOTAL
PERCENT					
ROW PCT					
COL PCT					
G	22	9	7	5	43
	7.03	2.88	2.24	1.60	13.74
	51.16	20.93	16.28	11.63	
	15.71	19.57	12.07	7.25	
H	37	20	13	23	93
	11.82	6.39	4.15	7.35	29.71
	39.78	21.51	13.98	24.73	
	26.43	43.48	22.41	33.33	
O	10	4	5	12	31
	3.19	1.28	1.60	3.83	9.90
	32.26	12.90	16.13	38.71	
	7.14	8.70	8.62	17.39	
U	71	13	33	29	146
	22.68	4.15	10.54	9.27	46.65
	48.63	8.90	22.60	19.86	
	50.71	28.26	56.90	42.03	
TOTAL	140	46	58	69	313
	44.73	14.70	18.53	22.04	100.00

## SAUDI PUBLIC SURVEY

STATUS: G=GRADUATE STUDENTS U=UNDERGRADUATE STUDENTS  
H=HIGHSCHOOL STUDENTS O=CTHERS

ANSWER: 1=YES 2=INDIFFERENT 3=NO 4=NO-OPINION

TABLE OF STATUS BY Q39

STATUS	Q39				QUESTION39
FREQUENCY	1	2	3	4	TOTAL
PERCENT					
ROW PCT					
COL PCT					
G	18	11	5	9	43
	5.75	3.51	1.60	2.88	13.74
	41.86	25.58	11.63	20.93	
	12.59	14.47	20.00	13.04	
H	37	27	8	21	93
	11.82	8.63	2.56	6.71	29.71
	39.78	29.03	8.60	22.58	
	25.87	35.53	32.00	30.43	
O	13	10	2	6	31
	4.15	3.19	0.64	1.92	9.90
	41.94	32.26	6.45	19.35	
	9.09	13.16	8.00	8.70	
U	75	28	10	33	146
	23.96	8.95	3.19	10.54	46.65
	51.37	19.18	6.85	22.60	
	52.45	36.84	40.00	47.83	
TOTAL	143	76	25	69	313
	45.69	24.28	7.99	22.04	100.00

9.5. Cross Examination of Survey  
Response



## SAUDI PUBLIC SURVEY

STATUS: G=GRADUATE STUDENTS U=UNDERGRADUATE STUDENTS  
H=HIGHSCHOOL STUDENTS C=CTHERS

ANSWER: 1=YES 2=INDIFFERENT 3=NO 4=NC-CPINION

TABLE OF Q2 BY Q8

Q2	QUESTION2	Q8	QUESTION8	TOTAL	
FREQUENCY					
PERCENT					
ROW PCT					
CCL PCT	1	2	3	4	
1	52 16.61 55.32 32.30	12 3.83 12.77 24.00	25 7.99 26.60 26.74	5 1.60 5.32 33.33	94 30.03
2	64 20.45 53.78 39.75	22 7.03 18.49 44.00	29 9.27 24.37 33.33	4 1.28 3.36 26.67	119 38.02
3	40 12.78 44.94 24.84	14 4.47 15.73 28.00	31 9.90 34.83 35.63	4 1.28 4.49 26.67	89 28.43
4	5 1.60 45.45 3.11	2 0.64 18.18 4.00	2 0.64 18.18 2.30	2 0.64 18.18 13.33	11 3.51
TOTAL	161 51.44	50 15.97	87 27.80	15 4.79	313 100.00

## SAUDI PUBLIC SURVEY

STATUS: G=GRADUATE STUDENTS U=UNDERGRADUATE STUDENTS  
H=HIGHSCHOOL STUDENTS O=OTHERS

ANSWER: 1=YES 2=INDIFFERENT 3=NO 4=NO-OPINION

TABLE OF Q7 BY Q8

Q7	QUESTION7	Q8	QUESTION8		
FREQUENCY					
PERCENT					
ROW PCT					
COL PCT	1	2	3	4	TOTAL
1	116	16	29	9	170
	37.06	5.11	9.27	2.88	54.31
	68.24	9.41	17.06	5.29	
	72.05	32.00	33.33	60.00	
2	31	28	29	2	90
	9.90	8.95	9.27	0.64	28.75
	34.44	31.11	32.22	2.22	
	19.25	56.00	33.33	13.33	
3	11	5	26	2	44
	3.51	1.60	8.31	0.64	14.06
	25.00	11.36	59.09	4.55	
	6.83	10.00	29.89	13.33	
4	3	1	3	2	9
	0.96	0.32	0.96	0.64	2.88
	33.33	11.11	33.33	22.22	
	1.86	2.00	3.45	13.33	
TOTAL	161	50	87	15	313
	51.44	15.97	27.80	4.79	100.00

## SAUDI PUBLIC SURVEY

STATUS: G=GRADUATE STUDENTS U=UNDERGRADUATE STUDENTS  
 H=HIGHSCHOOL STUDENTS O=OTHERS

ANSWER: 1=YES 2=INDIFFERENT 3=NO 4=NO-CPINION

TABLE OF Q9 BY Q28

Q9	QUESTION9	Q28	QUESTION28					
FREQUENCY	PERCENT	ROW PCT	COL PCT	1	2	3	4	TOTAL
1	10	11	83	91	195			
	3.19	3.51	26.52	29.07	62.30			
	5.13	5.64	42.56	46.67				
	34.48	44.00	73.45	62.33				
2	4	11	10	11	36			
	1.28	3.51	3.19	3.51	11.50			
	11.11	30.56	27.78	30.56				
	13.79	44.00	8.85	7.53				
3	11	2	13	11	37			
	3.51	0.64	4.15	3.51	11.82			
	29.73	5.41	35.14	29.73				
	37.93	8.00	11.50	7.53				
4	4	1	7	33	45			
	1.28	0.32	2.24	10.54	14.38			
	8.89	2.22	15.56	73.33				
	13.79	4.00	6.19	22.60				
TOTAL	29	25	113	146	313			
	9.27	7.99	36.10	46.65	100.00			

## SAUDI PUBLIC SURVEY

STATUS: G=GRADUATE STUDENTS U=UNDERGRADUATE STUDENTS  
H=HIGHSCHOOL STUDENTS O=CTHERS

ANSWER: 1=YES 2=INDIFFERENT 3=NO 4=NC-OPINION

TABLE OF Q13 BY Q16

Q13	QUESTION13		Q16		QUESTION16			
FREQUENCY	PERCENT	ROW PCT	COL PCT	1	2	3	4	TOTAL
1	15	8	8	21	52			
	4.79	2.56	2.56	6.71	16.61			
	28.85	15.36	15.38	40.38				
	16.13	13.56	14.81	19.63				
2	33	25	19	29	106			
	10.54	7.99	6.07	9.27	33.87			
	31.13	23.58	17.92	27.36				
	35.48	42.37	35.19	27.10				
3	36	25	24	45	130			
	11.50	7.99	7.67	14.38	41.53			
	27.69	19.23	18.46	34.62				
	38.71	42.37	44.44	42.06				
4	9	1	3	12	25			
	2.88	0.32	0.96	3.83	7.99			
	36.00	4.00	12.00	48.00				
	9.68	1.69	5.56	11.21				
TOTAL	93	59	54	107	313			
	29.71	18.85	17.25	34.19	100.00			

## SAUDI PUBLIC SURVEY

STATUS: G=GRADUATE STUDENTS U=UNDERGRADUATE STUDENTS  
H=HIGHSCHOOL STUDENTS C=CTHERS

ANSWER: 1=YES 2=INDIFFERENT 3=NO 4=NO-OPINION

TABLE OF Q13 BY Q17

Q13	QUESTION13		Q17		QUESTION17		
FREQUENCY							
PERCENT							
ROW PCT							
COL PCT	1	2	3	4	TOTAL		
1	3	3	19	27	52		
	0.96	0.96	6.07	8.63	16.61		
	5.77	5.77	36.54	51.92			
	4.84	13.04	21.59	19.29			
2	28	9	30	39	106		
	8.95	2.88	9.58	12.46	33.87		
	26.42	8.49	28.30	36.79			
	45.16	39.13	34.09	27.86			
3	27	9	36	58	130		
	8.63	2.88	11.50	18.53	41.53		
	20.77	6.92	27.69	44.62			
	43.55	39.13	40.91	41.43			
4	4	2	3	16	25		
	1.28	0.64	0.96	5.11	7.99		
	16.00	8.00	12.00	64.00			
	6.45	8.70	3.41	11.43			
TOTAL	62	23	88	140	313		
	19.81	7.35	28.12	44.73	100.00		



## SAUDI PUBLIC SURVEY

STATUS: G=GRADUATE STUDENTS U=UNDERGRADUATE STUDENTS  
H=HIGHSCHOOL STUDENTS O=OTHERS

ANSWER: 1=YES 2=INDIFFERENT 3=NO 4=NO-CPINION

TABLE OF Q13 BY Q19

Q13	QUESTION13	Q19	QUESTION19		
FREQUENCY	PERCENT	ROW PCT	COL PCT	TOTAL	
	1	2	3	4	
1	34	6	1	11	52
	10.86	1.92	0.32	3.51	16.61
	65.38	11.54	1.92	21.15	
	17.71	23.08	6.25	13.92	
2	60	12	6	28	106
	19.17	3.83	1.92	8.95	33.87
	56.60	11.32	5.66	26.42	
	31.25	46.15	37.50	35.44	
3	83	8	7	32	130
	26.52	2.56	2.24	10.22	41.53
	63.85	6.15	5.38	24.62	
	43.23	30.77	43.75	40.51	
4	15	0	2	8	25
	4.79	0.00	0.64	2.56	7.99
	60.00	0.00	8.00	32.00	
	7.81	0.00	12.50	10.13	
TOTAL	192	26	16	79	313
	61.34	8.31	5.11	25.24	100.00

## SAUDI PUBLIC SURVEY

STATUS: G=GRADUATE STUDENTS U=UNDERGRADUATE STUDENTS  
H=HIGHSCHOOL STUDENTS O=CTHERS

ANSWER: 1=YES 2=INDIFFERENT 3=NO 4=NO-OPINION

TABLE OF Q13 BY Q21

Q13	QUESTION13	Q21	QUESTION21		
FREQUENCY					
PERCENT					
ROW PCT					
CCL PCT	1	2	3	4	TOTAL
1	36	3	5	8	52
	11.50	0.96	1.60	2.56	16.61
	69.23	5.77	9.62	15.38	
	19.78	8.82	25.00	10.39	
2	59	17	6	24	106
	18.85	5.43	1.92	7.67	33.87
	55.66	16.04	5.66	22.64	
	32.42	50.00	30.00	31.17	
3	71	14	9	36	130
	22.68	4.47	2.88	11.50	41.53
	54.62	10.77	6.92	27.69	
	39.01	41.18	45.00	46.75	
4	16	0	0	9	25
	5.11	0.00	0.00	2.88	7.99
	64.00	0.00	0.00	36.00	
	8.79	0.00	0.00	11.69	
TOTAL	182	34	20	77	313
	58.15	10.86	6.39	24.60	100.00

## SAUDI PUBLIC SURVEY

STATUS: G=GRADUATE STUDENTS U=UNDERGRADUATE STUDENTS  
 H=HIGHSCHOOL STUDENTS O=CTHERS

ANSWER: 1=YES 2=INDIFFERENT 3=NO 4=NO-CPINION

TABLE OF Q13 BY Q25

Q13	QUESTION13	Q25	QUESTION25		
FREQUENCY					
PERCENT					
ROW PCT					
CGL PCT	1	2	3	4	TOTAL
1	35	8	4	5	52
	11.18	2.56	1.28	1.60	16.61
	67.31	15.38	7.69	9.62	
	16.43	18.18	17.39	15.15	
2	78	11	7	10	106
	24.92	3.51	2.24	3.19	33.87
	73.58	10.38	6.60	9.43	
	36.62	25.00	30.43	30.30	
3	83	24	11	12	130
	26.52	7.67	3.51	3.83	41.53
	63.85	18.46	8.46	9.23	
	38.97	54.55	47.83	36.36	
4	17	1	1	6	25
	5.43	0.32	0.32	1.92	7.99
	68.00	4.00	4.00	24.00	
	7.98	2.27	4.35	18.18	
TOTAL	213	44	23	33	313
	68.05	14.06	7.35	10.54	100.00

## SAUDI PUBLIC SURVEY

STATUS: G=GRADUATE STUDENTS U=UNDERGRADUATE STUDENTS  
H=HIGHSCHOOL STUDENTS C=OTHERS

ANSWER: 1=YES 2=INDIFFERENT 3=NO 4=NO-OPINION

TABLE OF Q13 BY Q31

Q13	QUESTION13	Q31	QUESTION31		
FREQUENCY					
PERCENT					
ROW PCT					
CGL PCT	1	2	3	4	TOTAL
1	13	2	14	23	52
	4.15	0.64	4.47	7.35	16.61
	25.00	3.85	26.92	44.23	
	31.71	5.13	15.56	16.08	
2	7	22	27	50	106
	2.24	7.03	8.63	15.97	33.87
	6.60	20.75	25.47	47.17	
	17.07	56.41	30.00	34.97	
3	17	15	45	53	130
	5.43	4.79	14.38	16.93	41.53
	13.08	11.54	34.62	40.77	
	41.46	38.46	50.00	37.06	
4	4	0	4	17	25
	1.28	0.00	1.28	5.43	7.99
	16.00	0.00	16.00	68.00	
	9.76	0.00	4.44	11.89	
TOTAL	41	39	90	143	313
	13.10	12.46	28.75	45.69	100.00

## SAUDI PUBLIC SURVEY

STATUS: G=GRADUATE STUDENTS U=UNDERGRADUATE STUDENTS  
H=HIGHSCHGCL STUDENTS O=CTHERS

ANSWER: 1=YES 2=INDIFFERENT 3=NO 4=NC-CFINION

TABLE OF Q13 BY Q34

Q13	QUESTION13		Q34	QUESTION34		
FREQUENCY						
PERCENT						
ROW PCT						
CGL PCT	1	2	3	4	TOTAL	
1	17	6	9	20	52	
	5.43	1.92	2.88	6.39	16.61	
	32.69	11.54	17.31	38.46		
	22.97	13.04	16.36	14.49		
2	24	19	19	44	106	
	7.67	6.07	6.07	14.06	33.87	
	22.64	17.92	17.92	41.51		
	32.43	41.30	34.55	31.88		
3	29	20	25	56	130	
	9.27	6.39	7.99	17.89	41.53	
	22.31	15.38	19.23	43.08		
	39.19	43.48	45.45	40.58		
4	4	1	2	18	25	
	1.28	0.32	0.64	5.75	7.99	
	16.00	4.00	8.00	72.00		
	5.41	2.17	3.64	13.04		
TOTAL	74	46	55	138	313	
	23.64	14.70	17.57	44.09	100.00	



10. APPENDIX B: UTILITY PROGRAMS

```

1. //E325 JOB UXXXXXX,TAWFIK
2. /STEP1 EXEC WATFIV
3. //GO.SYSIN DD *
4. $JOB KUSAYER,TIME=10,PAGES=10
5. C
6. C*****I*****
7. C THIS PROGRAM IS TO CALCULATE THE COEFFICIENTS,A,B,AND C .
8. C*****I*****
9. C
10. DO 100 I=1,N,1
11. READ,N,U3,X3
12. Z=1./U3-1.
13. C=ALOG(2)/X3
14. A=1./(1.-Z*Z)
15. B=-A
16. PRINT, A,B,C,X3,U3
17. 100 CONTINUE
18. $ENTRY
19. ...
20. ...
21. ...
22. ( INPUT DATA CARDS. )

```

```

1. //E325 JOB UXXXXXX,TAWFIK
2. //STEP1 EXEC WATFIV
3. //GO.SYSIN DD *
4. $JOB KUSAYER,TIME=10,PAGES=10
5. C
6. C*****
7. C THIS PROGRAM IS TO CALCULATE THE SCALING FACTOR ,K
8. C*****
9. C
10. DIMENSION X(10),U(10)
11. READ ,KK
12. READ ,(X(J),J=1, KK)
13. WRITE (6,1) (X(J),J=1, KK)
14. 1 FORMAT (///,'>>>VALUES OF K: ',6X, 4G10.4,/)
15. DO 100 I=2,1000,1
16. BK=(FLOAT(I)-1.0)*(-0.0001)
17. Y=BK+1.0
18. DO 20 J=1, KK
19. U(J)=(X(J)/6.0)*BK+1.0
20. 20 CONTINUE
21. R=1.0
22. DO 50 L=1, KK
23. R=U(L)*R
24. 50 CONTINUE
25. D=ABS(Y-R)
26. IF (D.LT..0001) GO TO 8
27. 100 CONTINUE
28. 8 PRINT ,Y,R,BK,I,D
29. STOP
30. END
31. $ENTRY
32. ...
33. ...
34. ...
35. ( INPUT DATA CARDS. )

```

```

1. //E325 JOB UXXXXXX,TAWFIK
2. //STEP1 EXEC WATFIV
3. //GO.SYSIN DD *
4. $JOB KUSAYER,TIME=10,PAGES=30
5. C
6. C*****
7. C THIS PROGRAM IS TO CALCULATE THE COMPONENT & OVERALL UTILITY.
8. C*****
9. C
10.     DIMENSION A(25),B(25),C(25),UI(25),X(25),SKI(25),S(25),Z(25)
11.     READ, K
12.     READ, (A(I),I=1,K)
13.     READ, (B(I),I=1,K)
14.     READ, (C(I),I=1,K)
15.     READ, (SKI(I),I=1,K)
16.     DO 50 M=1,3,1
17.     READ, (X(I),I=1,K)
18.     DO 10 I=1,K
19.     Z(I)=C(I)*X(I)
20.     UI(I)=A(I)+B(I)*EXP(Z(I))
21.     WRITE (6,2) I, UI(I)
22.     2 FORMAT ( ' THE VALUE OF COMPONENT UTILITY ', '(I2,')',G12.5,/)
23.     10 CONTINUE
24.     BK=-.578
25.     DO 20 N=1,K
26.     S(N)=BK*(SKI(N)/1.00)* UI(N)+1.0
27.     20 CONTINUE
28.     R=1.0
29.     DO 30 NN=1,K
30.     R=S(NN)*R
31.     30 CONTINUE
32.     U=R/BK-1.0/BK
33.     WRITE (6,3) U
34.     3 FORMAT ( / , ' THE OVERALL UTILITY VALUE IS =',G12.5,15X,///)
35.     50 CONTINUE
36.     STOP
37.     END
38. $ENTRY
39.     ...
40.     ...
41.     ...
42.     ( INPUT DATA CARDS. )

```

```

1. //E325 JOB U3516TH,TAWFIK
2. //STEP1 EXEC WATFIV
3. //GO.SYSIN DD *
4. $JOB KUSAYER,TIME=15,PAGES=50
5. C
6. C*****
7. C THIS PROGRAM IS TO PLOT THE UTILITY CURVES.
8. C*****
9. C
10. C
11. DIMENSION X(80),Y(80),XLAB(5),YLAB(5),GLAB(5),DATLAB(5)
12. XSIZE=5.5
13. YSIZE=5.5
14. YMIN=0.0
15. YSF=.2
16. ISYM=3
17. NPTS=61
18. MODE=15
19. READ, KK
20. DO 100 I=1, KK
21. READ (5,1) XLAB,YLAB,GLAB,DATLAB
22. 1 FORMAT (20A4)
23. READ, A,B,C
24. READ, P,XSF,XMIN
25. DO 10 N=1,61
26. X(N)=(FLOAT(N)-1.0)/60.*P
27. Y(N)=A+B*EXP(C*X(N))
28. 10 CONTINUE
29. WRITE (6,2) A,B,C
30. 2 FORMAT ('1',//,T20,3G15.4)
31. CALL GRAPH (NPTS,X,Y,ISYM,MODE,XSIZE,YSIZE,XSF,
32. 1XMIN,YSF,YMIN,XLAB,YLAB,GLAB,DATLAB)
33. 100 CONTINUE
34. STOP
35. END
36. $ENTRY
37. ...
38. ...
39. ...
40. (INPUT DATA CARDS.)
41. ...
42. //GO.FT14F001 DD DSNNAME=&SM,UNIT=SCRTCH,DISP=(NEW,PASS),
43. // SPACE=(800,(120,15)),DCB=(RECFM=VBS,LRECL=796,BLKSIZE 800)
44. //SMPLTR EXEC PLOT,PLOTTER=PRINTER
45. //SMPL2 EXEC PLOT,PLOTTER=INCRMNTL,FORM=W
46. //

```



## 11. APPENDIX C: SAINT PROGRAM

### 11.1. The Main Program

SAINT, Systems Analysis of Integrated Networks of Tasks, is a package of computer routines (FORTRAN subprograms) designed to aid the system designer and human engineer in analyzing complex man-machine systems. It provides the conceptual framework which allows the development of system models in which men, machines, and the environment are represented. It permits the assessment of the effect of the component characteristics of the system on overall system performance.

```

1. C*****
2. C
3. C   THIS IS THE MAIN PROGRAM IN   SAINT
4. C
5. C*****
6. C
7. C
8.     COMMON /COM01/ ID,IM,IMM,IMNA,IMN,MAXDS,MDAD,MDDR,MDNPT,MDNSS,      00000030
9.     * MDOAT,MDQP,MDSTR,MEQT,MFLAG,MMPTS,MDFN,MMSTU,                    00000040
10.    * MNCEL,MNCLS,MNCLT,MNCUP,MNHIS,MNOPA,MNPLT,MNPTQ,                 00000050
11.    * MNSTP,MNSWA,MNVAR,MNVPP,MOPNO,MPARM,MPLT,MSTAT,                  00000060
12.    * MSYAT,MTCHR,MXSTA,MYABA,NQ                                        00000070
13.     COMMON /COM02/ ATRIB(3),JTRIB(2),QSET(300),NSET(400),MFA,MXX,      00000080
14.    * MFE(3),MLE(3),NQ(3)                                             00000090
15.     COMMON /COM03/ IPOS,JPOS,KPOS,LPOS,MPOS,NPA,NAN,IERRW,IERRF,IFIN,  00000100
16.    * IIECH,INDXS,INDXT,INDX,JNDX,KNDX,IP,NUMFL,ICONT,                00000110
17.    * IISED,HIVAL,IBLNK,IZERO,LA,LB,LC,LD,LE,LF,LG,LH,LI,             00000120
18.    * LJ,LK,LL,LM,LN,LO,LP,LQ,LR,LS,LT,LU,LV,LW,LX,LY,LZ             00000130
19.     COMMON /COM04/ IDFAL(4),KREAD(40),IFLAG(50),IRSUL(50),RESUL(50),  00000140
20.    * IABC(8,50),KARD(80),IDI(9)                                       00000150
21.     COMMON /COM05/ NPROJ,MON,NDAY,NYR,NAME(2),NRUN,NRUNS,NSKSR,      00000160
22.    * NSKST,LLCVD,NNEQD,NNEQS,NNEQT                                     00000170
23.     COMMON /COM06/ TNOW,TTNEX,MFAD,SEED,ISEED,NCRDR,NPRNT,NPUNCH,    00000180
24.    * NRNIT,NRENT,MNDC,NDC,NDTN,NNTC                                   00000190
25.     COMMON /COM07/ NDE,NOPAT,NSYAT,NDOP,NNM,NNPA,NMDFN,NN,NPRMS,IFLPR,00000200
26.    * JFLPR,KRKN,XINN,NFLAG,NNCLT,NNHIS,NNPLT,NNSTA,                 00000210
27.    * NNSTP,NPLOT,NSTTS                                               00000220
28.     COMMON /COM08/ NEIP,NEIS,NSIP,NSIS,ITRACE,JTRACE,NRTSP,NRTEP,    00000230
29.    * KTRACE,MTRACE,IIRSR,IISR,IGRAF,JGRAF,IJTRAC,                   00000240
30.    * NSVUS,NSVVE,NTSOE,NTSOS,LTRACE,NRTSS,NRTES                     00000250

```

31.	COMMON /COM09/	PARAM(100,5),NFTBU(100),PARM1(100),PARM4(100)	00000260
32.	COMMON /COM10/	CACIN(100,3),ITCHR(100),LLTSK(100,2),LSINK(100),	00000270
33.	*	MACIN(100,4),MFEN(100),MFSTT(100),NFTBU(100),	00000280
34.	*	MOP(100),MPO(100),NDCH(100,2),NDEL(100),NDPT(100),	00000290
35.	*	NPAR(100),NPO(100),NPODR(100),NPODS(100),NPOP(100),	00000300
36.	*	NPOR(100),NPSGN(100),NREL(100),NRELP(100),	00000310
37.	*	NREL2(100),NSIGN(100),NTC(100),NTCHR(100),	00000320
38.	*	NTYPE(100),KMARK(100),XMARK(100)	00000330
39.	COMMON /COM11/	BUSY(20),LLRES(20,2),NBUS(20),NOPTR(20),TLST(20),	00000340
40.	*	NOPA(600),RSTAT(80)	00000350
41.	COMMON /COM12/	YABA(850),NABA(250),STCHR(200)	00000360
42.	COMMON /COM13/	MDFNS(20),MFSTW(20),MFSTU(300)	00000370
43.	COMMON /COM14/	NSINK(50),KSTPE(50),KSTTM(50),XSTUS(50),NCELS(50),	00000380
44.	*	XLOW(50),WIDTH(50),SUMAI(50,5),SUMAF(50,5),	00000390
45.	*	JCELS(1350)	00000400
46.	COMMON /COM15/	DESCR(1000),DOATT(100),NDSTR(800),SYSAT(100)	00000410
47.	COMMON /COM16/	AAERR,DTMAX,DTMIN,DTSAV,IITES,LLERR,RRERR,TTLAS,	00000420
48.	*	TTSAV,DTSUG,DTFUL,DTNOW,ISEES,RESLS,DTACC,LLSAV,	00000430
49.	*	LSAVE	00000440
50.	COMMON /COM17/	SS(100),SSL(100),DD(100),DDL(100),LLSVR(100,2)	00000450
51.	COMMON /COM18/	IS(20),NABAD(300),YABAR(600)	00000460
52.	COMMON /COM19/	LFLAG(20),NPOSS(20),NPOST(20),LLMON(20,2),	00000470
53.	*	NABAT(40),NABAS(60),THRES(120)	00000480
54.	COMMON /COM20/	NSTAI(20),LLSVS(20,2),SSTPV(20,6)	00000490
55.	COMMON /COM21/	DTPLT(10),IITAF(10),NNPTS(10),NNVAR(10),NNVP(10),	00000500
56.	*	LLPLT,NNPT,LLPHI(10),LLPLO(10),LLSYM(10),PPHI(10),	00000510
57.	*	PPLO(10),NVP(100),LLSVP(11,2),QPSET(1100)	00000520
58.	COMMON /COM22/	TTIME,PFIRB	00000530
59.	COMMON /COM23/	LLUGC(20,2),USOBV(20,5),LLUGT(20,2),TTCLR(20),	00000540
60.	*	USTPV(20,6),LLUGH(20,2),NNCEL(20),HHLOW(20),	00000550

61.	*	HHWID(20),JJCEL(540)	00000560
62.		COMMON /COM24/ DPLOT(10),ITAPE(10),NPTSV(10),NVAR(10),LPLOT,	00000570
63.	*	NPTX,LPHIH(10),LPLOW(10),LSYMB(10),PHIH(10),	00000580
64.	*	FLOW(10),LLUGF(11,2),UPSET(1100)	00000590
65.	C		00000600
66.		C*****INITIALIZE READ, PRINT, AND PUNCH KEYS	00000610
67.	C		00000620
68.		NCRDR=5	00000630
69.		NPRNT=6	00000640
70.		NPUNCH=7	00000650
71.		NRNIT=8	00000660
72.		NRENT=9	00000670
73.	C		00000680
74.		C*****DEFINE VARIABLES WHICH REPRESENT ARRAY MAXIMA AND SIMULATION	00000690
75.		C*****LIMITS	00000700
76.	C		00000710
77.		ID=100	00000720
78.		IMN=100	00000730
79.		IMNA=250	00000740
80.		MAXDS=1000	00000750
81.		MDAD=300	00000760
82.		MDDR=600	00000770
83.		MDNPT=40	00000780
84.		MDNSS=60	00000790
85.		MDQAT=100	00000800
86.		MDQP=1100	00000810
87.		MDSTR=800	00000820
88.		MEQT=100	00000830
89.		MFLAG=20	00000840
90.		MMDFN=20	00000850



91.	MMSTU=300	00000860
92.	MNCEL=540	00000870
93.	MNCLS=1350	00000880
94.	MNCLT=20	00000890
95.	MNCUP=1100	00000900
96.	MNHIS=20	00000910
97.	MNOFA=600	00000920
98.	MNPLT=10	00000930
99.	MNSTP=20	00000940
100.	MNSWA=20	00000950
101.	MNVAR=10	00000960
102.	MNVPP=10	00000970
103.	MOPNO=20	00000980
104.	MPARM=100	00000990
105.	MPLOT=10	00001000
106.	MSTAT=20	00001010
107.	MSYAT=100	00001020
108.	MTCHR=200	00001030
109.	MXSTA=50	00001040
110.	MYABA=850	00001050
111.	C	00001060
112.	C*****EXECUTION CYCLE -- READ INPUT DATA, THEN INITIATE THE SIMULATION	00001070
113.	C	00001080
114.	IFIN=0	00001090
115.	100 CALL DATIN	00001100
116.	IF(IERRF.EQ.0) CALL GASP	00001110
117.	IF(IERRF.EQ.0) CALL SUMRY	00001120
118.	IF (IFIN.EQ.0) GO TO 100	00001130
119.	STOP	00001140
120.	C	00001150
121.	END	00001160



11.2. State Variable Table for  
Iteration Number 1







































































11.3. Detailed Output of  
Iteration Number 1

\*\*DETAILED OUTPUT OF ITERATION NUMBER 1\*\*

TASK OR MONITOR NUMBER	TASK OR MONITOR LABEL	TASK PRIORITY	EVENT TYPE	TIME OF EVENT	-----RESOURCES ASSIGNED TO TASK-----
10	START	0.0	RELEASE	0.0	
48	TLR3 1	0.0	RELEASE	0.0	
10	START	0.0	START	0.0	
48	TLR3 1	0.0	START	0.0	
SPECIFIED TOLERANCE EXCEEDED FOR SS( 19) AT TIME 0.4827E-01					
3	MM 3		MONITOR	0.05	
SPECIFIED TOLERANCE EXCEEDED FOR SS( 19) AT TIME 0.1371E 00					
1	MM 1		MONITOR	0.14	
10	START		* COMPLETE	0.51	
20	RESTART	0.0	RELEASE	0.51	
20	RESTART	0.0	START	0.51	
20	RESTART		* COMPLETE	0.51	
22	DS2 UNB	0.0	RELEASE	0.51	
22	DS2 UNB	0.0	START	0.51	
22	DS2 UNB		* COMPLETE	0.51	
36	TH11 ACC	0.0	RELEASE	0.51	
36	TH11 ACC	0.0	START	0.51	
36	TH11 ACC		* COMPLETE	0.51	
10	START	0.0	RELEASE	0.51	
10	START	0.0	START	0.51	
10	START		* COMPLETE	1.03	
10	START	0.0	RELEASE	1.03	
10	START	0.0	START	1.03	
10	START		* COMPLETE	1.60	
10	START	0.0	RELEASE	1.60	
10	START	0.0	START	1.60	
10	START		* COMPLETE	1.96	
10	START	0.0	RELEASE	1.96	
10	START	0.0	START	1.96	
10	START		* COMPLETE	2.27	
10	START	0.0	RELEASE	2.27	
10	START	0.0	START	2.27	
10	START		* COMPLETE	2.63	
10	START	0.0	RELEASE	2.63	
10	START	0.0	START	2.63	
10	START		* COMPLETE	3.11	
10	START	0.0	RELEASE	3.11	
10	START	0.0	START	3.11	
10	START		* COMPLETE	3.45	

10	START	0.0	RELEASE	3.45
10	START	0.0	START	3.45
10	START		* COMPLETE	4.07
10	START	0.0	RELEASE	4.07
10	START	0.0	START	4.07
10	START		* COMPLETE	4.57
10	START	0.0	RELEASE	4.57
10	START	0.0	START	4.57
10	START		* COMPLETE	5.11
10	START	0.0	RELEASE	5.11
10	START	0.0	START	5.11
10	START		* COMPLETE	5.79
10	START	0.0	RELEASE	5.79
10	START	0.0	START	5.79
10	START		* COMPLETE	6.18
10	START	0.0	RELEASE	6.18
10	START	0.0	START	6.18
10	START		* COMPLETE	6.59
10	START	0.0	RELEASE	6.59
10	START	0.0	START	6.59
10	START		* COMPLETE	6.96
10	START	0.0	RELEASE	6.96
10	START	0.0	START	6.96
10	START		* COMPLETE	7.62
10	START	0.0	RELEASE	7.62
10	START	0.0	START	7.62
10	START		* COMPLETE	8.15
10	START	0.0	RELEASE	8.15
10	START	0.0	START	8.15
10	START		* COMPLETE	8.64
10	START	0.0	RELEASE	8.64
10	START	0.0	START	8.64
10	START		* COMPLETE	9.04
10	START	0.0	RELEASE	9.04
10	START	0.0	START	9.04
10	START		* COMPLETE	9.69
10	START	0.0	RELEASE	9.69
10	START	0.0	START	9.69
10	START		* COMPLETE	10.23
10	START	0.0	RELEASE	10.23
10	START	0.0	START	10.23
10	START		* COMPLETE	10.69
10	START	0.0	RELEASE	10.69
10	START	0.0	START	10.69
10	START		* COMPLETE	11.20

10	START	0.0	RELEASE	11.20
10	START	0.0	START	11.20
10	START		* COMPLETE	11.79
10	START	0.0	RELEASE	11.79
10	START	0.0	START	11.79
48	TLR3 1		* COMPLETE	12.00
49	TLR3 2	0.0	RELEASE	12.00
49	TLR3 2	0.0	START	12.00
10	START		* COMPLETE	12.40
20	RESTART	0.0	RELEASE	12.40
20	RESTART	0.0	START	12.40
20	RESTART		* COMPLETE	12.40
22	DS2 UNB	0.0	RELEASE	12.40
22	DS2 UNB	0.0	START	12.40
22	DS2 UNB		* COMPLETE	12.40
36	TH11 ACC	0.0	RELEASE	12.40
36	TH11 ACC	0.0	START	12.40
36	TH11 ACC		* COMPLETE	12.40
10	START	0.0	RELEASE	12.40
10	START	0.0	START	12.40
10	START		* COMPLETE	12.81
10	START	0.0	RELEASE	12.81
10	START	0.0	START	12.81
10	START		* COMPLETE	13.46
10	START	0.0	RELEASE	13.46
10	START	0.0	START	13.46
10	START		* COMPLETE	14.10
10	START	0.0	RELEASE	14.10
10	START	0.0	START	14.10
10	START		* COMPLETE	14.69
10	START	0.0	RELEASE	14.69
10	START	0.0	START	14.69
10	START		* COMPLETE	15.08
10	START	0.0	RELEASE	15.08
10	START	0.0	START	15.08
10	START		* COMPLETE	15.69
10	START	0.0	RELEASE	15.69
10	START	0.0	START	15.69
10	START		* COMPLETE	16.07
10	START	0.0	RELEASE	16.07
10	START	0.0	START	16.07
10	START		* COMPLETE	16.60
10	START	0.0	RELEASE	16.60
10	START	0.0	START	16.60
10	START		* COMPLETE	17.28

10	START	0.0	RELEASE	17.28
10	START	0.0	START	17.28
10	START		* COMPLETE	17.68
10	START	0.0	RELEASE	17.68
10	START	0.0	START	17.68
10	START		* COMPLETE	18.28
10	START	0.0	RELEASE	18.28
10	START	0.0	START	18.28
10	START		* COMPLETE	18.73
10	START	0.0	RELEASE	18.73
10	START	0.0	START	18.73
10	START		* COMPLETE	19.13
10	START	0.0	RELEASE	19.13
10	START	0.0	START	19.13
10	START		* COMPLETE	19.67
10	START	0.0	RELEASE	19.67
10	START	0.0	START	19.67
10	START		* COMPLETE	20.16
10	START	0.0	RELEASE	20.16
10	START	0.0	START	20.16
10	START		* COMPLETE	20.72
10	START	0.0	RELEASE	20.72
10	START	0.0	START	20.72
10	START		* COMPLETE	21.18
10	START	0.0	RELEASE	21.18
10	START	0.0	START	21.18
10	START		* COMPLETE	21.70
10	START	0.0	RELEASE	21.70
10	START	0.0	START	21.70
49	TURB 2		* COMPLETE	22.00
48	TURB 1	0.0	RELEASE	22.00
48	TURB 1	0.0	START	22.00
10	START		* COMPLETE	22.31
20	RESTART	0.0	RELEASE	22.31
20	RESTART	0.0	START	22.31
20	RESTART		* COMPLETE	22.31
22	DS2 UNB	0.0	RELEASE	22.31
22	DS2 UNB	0.0	START	22.31
22	DS2 UNB		* COMPLETE	22.31
36	TH11 ACC	0.0	RELEASE	22.31
36	TH11 ACC	0.0	START	22.31
36	TH11 ACC		* COMPLETE	22.31
10	START	0.0	RELEASE	22.31
10	START	0.0	START	22.31
10	START		* COMPLETE	22.65



10	START	0.0	RELEASE	22.65
10	START	0.0	START	22.65
10	START		* COMPLETE	23.21
10	START	0.0	RELEASE	23.21
10	START	0.0	START	23.21
10	START		* COMPLETE	23.74
10	START	0.0	RELEASE	23.74
10	START	0.0	START	23.74
10	START		* COMPLETE	24.21
10	START	0.0	RELEASE	24.21
10	START	0.0	START	24.21
10	START		* COMPLETE	24.68
10	START	0.0	RELEASE	24.68
10	START	0.0	START	24.68
10	START		* COMPLETE	25.16
10	START	0.0	RELEASE	25.16
10	START	0.0	START	25.16
10	START		* COMPLETE	25.68
10	START	0.0	RELEASE	25.68
10	START	0.0	START	25.68
10	START		* COMPLETE	26.18
10	START	0.0	RELEASE	26.18
10	START	0.0	START	26.18
10	START		* COMPLETE	26.87
10	START	0.0	RELEASE	26.87
10	START	0.0	START	26.87
10	START		* COMPLETE	27.43
10	START	0.0	RELEASE	27.43
10	START	0.0	START	27.43
10	START		* COMPLETE	27.86
10	START	0.0	RELEASE	27.86
10	START	0.0	START	27.86
10	START		* COMPLETE	28.47
10	START	0.0	RELEASE	28.47
10	START	0.0	START	28.47
10	START		* COMPLETE	29.11
10	START	0.0	RELEASE	29.11
10	START	0.0	START	29.11
10	START		* COMPLETE	29.66
10	START	0.0	RELEASE	29.66
10	START	0.0	START	29.66
10	START		* COMPLETE	30.05
10	START	0.0	RELEASE	30.05
10	START	0.0	START	30.05
10	START		* COMPLETE	30.40

10	START	0.0	RELEASE	30.40
10	START	0.0	START	30.40
10	START		* COMPLETE	31.02
10	START	0.0	RELEASE	31.02
10	START	0.0	START	31.02
10	START		* COMPLETE	31.50
10	START	0.0	RELEASE	31.50
10	START	0.0	START	31.50
10	START		* COMPLETE	32.00
10	START	0.0	RELEASE	32.00
10	START	0.0	START	32.00
10	START		* COMPLETE	32.41
10	START	0.0	RELEASE	32.41
10	START	0.0	START	32.41
10	START		* COMPLETE	32.94
10	START	0.0	RELEASE	32.94
10	START	0.0	START	32.94
10	START		* COMPLETE	33.37
10	START	0.0	RELEASE	33.37
10	START	0.0	START	33.37
10	START		* COMPLETE	33.91
10	START	0.0	RELEASE	33.91
10	START	0.0	START	33.91
48	TURB 1		* COMPLETE	34.00
49	TURB 2	0.0	RELEASE	34.00
49	TURB 2	0.0	START	34.00
10	START		* COMPLETE	34.62
20	RESTART	0.0	RELEASE	34.62
20	RESTART	0.0	START	34.62
20	RESTART		* COMPLETE	34.62
22	DS2 UNB	0.0	RELEASE	34.62
22	DS2 UNB	0.0	START	34.62
22	DS2 UNB		* COMPLETE	34.62
36	TH11 ACC	0.0	RELEASE	34.62
36	TH11 ACC	0.0	START	34.62
36	TH11 ACC		* COMPLETE	34.62
10	START	0.0	RELEASE	34.62
10	START	0.0	START	34.62
10	START		* COMPLETE	34.96
10	START	0.0	RELEASE	34.96
10	START	0.0	START	34.96
10	START		* COMPLETE	35.46
10	START	0.0	RELEASE	35.46
10	START	0.0	START	35.46
10	START		* COMPLETE	35.94

10	START	0.0	RELEASE	35.94
10	START	0.0	START	35.94
10	START		* COMPLETE	36.42
10	START	0.0	RELEASE	36.42
10	START	0.0	START	36.42
10	START		* COMPLETE	36.84
10	START	0.0	RELEASE	36.84
10	START	0.0	START	36.84
10	START		* COMPLETE	37.28
10	START	0.0	RELEASE	37.28
10	START	0.0	START	37.28
10	START		* COMPLETE	37.84
10	START	0.0	RELEASE	37.84
10	START	0.0	START	37.84
10	START		* COMPLETE	38.18
10	START	0.0	RELEASE	38.18
10	START	0.0	START	38.18
10	START		* COMPLETE	38.56
10	START	0.0	RELEASE	38.56
10	START	0.0	START	38.56
10	START		* COMPLETE	38.97
10	START	0.0	RELEASE	38.97
10	START	0.0	START	38.97
10	START		* COMPLETE	39.57
10	START	0.0	RELEASE	39.57
10	START	0.0	START	39.57
10	START		* COMPLETE	40.13
10	START	0.0	RELEASE	40.13
10	START	0.0	START	40.13
10	START		* COMPLETE	40.70
10	START	0.0	RELEASE	40.70
10	START	0.0	START	40.70
10	START		* COMPLETE	41.22
10	START	0.0	RELEASE	41.22
10	START	0.0	START	41.22
10	START		* COMPLETE	41.65
10	START	0.0	RELEASE	41.65
10	START	0.0	START	41.65
10	START		* COMPLETE	42.15
10	START	0.0	RELEASE	42.15
10	START	0.0	START	42.15
10	START		* COMPLETE	42.62
10	START	0.0	RELEASE	42.62
10	START	0.0	START	42.62
10	START		* COMPLETE	42.91

10	START	0.0	RELEASE	42.91
10	START	0.0	START	42.91
10	START		* COMPLETE	43.33
10	START	0.0	RELEASE	43.33
10	START	0.0	START	43.33
10	START		* COMPLETE	43.85
10	START	0.0	RELEASE	43.85
10	START	0.0	START	43.85
49	TURB 2		* COMPLETE	44.00
48	TURB 1	0.0	RELEASE	44.00
48	TURB 1	0.0	START	44.00
10	START		* COMPLETE	44.41
20	RESTART	0.0	RELEASE	44.41
20	RESTART	0.0	START	44.41
20	RESTART		* COMPLETE	44.41
22	DS2 UNB	0.0	RELEASE	44.41
22	DS2 UNB	0.0	START	44.41
22	DS2 UNB		* COMPLETE	44.41
36	TH11 ACC	0.0	RELEASE	44.41
36	TH11 ACC	0.0	START	44.41
36	TH11 ACC		* COMPLETE	44.41
10	START	0.0	RELEASE	44.41
10	START	0.0	START	44.41
10	START		* COMPLETE	44.81
10	START	0.0	RELEASE	44.81
10	START	0.0	START	44.81
10	START		* COMPLETE	45.27
10	START	0.0	RELEASE	45.27
10	START	0.0	START	45.27
10	START		* COMPLETE	45.72
10	START	0.0	RELEASE	45.72
10	START	0.0	START	45.72
10	START		* COMPLETE	46.23
10	START	0.0	RELEASE	46.23
10	START	0.0	START	46.23
10	START		* COMPLETE	46.66
10	START	0.0	RELEASE	46.66
10	START	0.0	START	46.66
10	START		* COMPLETE	47.05
10	START	0.0	RELEASE	47.05
10	START	0.0	START	47.05
10	START		* COMPLETE	47.54
10	START	0.0	RELEASE	47.54
10	START	0.0	START	47.54
10	START		* COMPLETE	48.20

10	START	0.0	RELEASE	48.20
10	START	0.0	START	48.20
10	START		* COMPLETE	48.71
10	START	0.0	RELEASE	48.71
10	START	0.0	START	48.71
10	START		* COMPLETE	49.36
10	START	0.0	RELEASE	49.36
10	START	0.0	START	49.36
10	START		* COMPLETE	49.90
10	START	0.0	RELEASE	49.90
10	START	0.0	START	49.90
10	START		* COMPLETE	50.24
10	START	0.0	RELEASE	50.24
10	START	0.0	START	50.24
10	START		* COMPLETE	50.64
10	START	0.0	RELEASE	50.64
10	START	0.0	START	50.64
10	START		* COMPLETE	51.29
10	START	0.0	RELEASE	51.29
10	START	0.0	START	51.29
10	START		* COMPLETE	52.05
10	START	0.0	RELEASE	52.05
10	START	0.0	START	52.05
10	START		* COMPLETE	52.40
10	START	0.0	RELEASE	52.40
10	START	0.0	START	52.40
10	START		* COMPLETE	52.89
10	START	0.0	RELEASE	52.89
10	START	0.0	START	52.89
10	START		* COMPLETE	53.38
10	START	0.0	RELEASE	53.38
10	START	0.0	START	53.38
10	START		* COMPLETE	53.72
10	START	0.0	RELEASE	53.72
10	START	0.0	START	53.72
10	START		* COMPLETE	54.28
10	START	0.0	RELEASE	54.28
10	START	0.0	START	54.28
10	START		* COMPLETE	54.68
10	START	0.0	RELEASE	54.68
10	START	0.0	START	54.68
10	START		* COMPLETE	55.02
10	START	0.0	RELEASE	55.02
10	START	0.0	START	55.02
10	START		* COMPLETE	55.39



10	START	0.0	RELEASE	55.39
10	START	0.0	START	55.39
10	START		* COMPLETE	55.97
10	START	0.0	RELEASE	55.97
10	START	0.0	START	55.97
48	TURB 1		* COMPLETE	56.00
49	TURB 2	0.0	RELEASE	56.00
49	TURB 2	0.0	START	56.00
10	START		* COMPLETE	56.45
20	RESTART	0.0	RELEASE	56.45
20	RESTART	0.0	START	56.45
20	RESTART		* COMPLETE	56.45
22	DS2 UNB	0.0	RELEASE	56.45
22	DS2 UNB	0.0	START	56.45
22	DS2 UNB		* COMPLETE	56.45
36	TH11 ACC	0.0	RELEASE	56.45
36	TH11 ACC	0.0	START	56.45
36	TH11 ACC		* COMPLETE	56.45
10	START	0.0	RELEASE	56.45
10	START	0.0	START	56.45
10	START		* COMPLETE	56.92
10	START	0.0	RELEASE	56.92
10	START	0.0	START	56.92
10	START		* COMPLETE	57.51
10	START	0.0	RELEASE	57.51
10	START	0.0	START	57.51
10	START		* COMPLETE	57.93
10	START	0.0	RELEASE	57.93
10	START	0.0	START	57.93
10	START		* COMPLETE	58.33
10	START	0.0	RELEASE	58.33
10	START	0.0	START	58.33
10	START		* COMPLETE	58.85
10	START	0.0	RELEASE	58.85
10	START	0.0	START	58.85
10	START		* COMPLETE	59.46
10	START	0.0	RELEASE	59.46
10	START	0.0	START	59.46
10	START		* COMPLETE	59.69
10	START	0.0	RELEASE	59.69
10	START	0.0	START	59.69
10	START		* COMPLETE	60.18
10	START	0.0	RELEASE	60.18
10	START	0.0	START	60.18
10	START		* COMPLETE	60.58

10	START	0.0	RELEASE	60.58
10	START	0.0	START	60.58
10	START		* COMPLETE	60.96
10	START	0.0	RELEASE	60.96
10	START	0.0	START	60.96
10	START		* COMPLETE	61.58
10	START	0.0	RELEASE	61.58
10	START	0.0	START	61.58
10	START		* COMPLETE	62.07
10	START	0.0	RELEASE	62.07
10	START	0.0	START	62.07
10	START		* COMPLETE	62.59
10	START	0.0	RELEASE	62.59
10	START	0.0	START	62.59
10	START		* COMPLETE	63.07
10	START	0.0	RELEASE	63.07
10	START	0.0	START	63.07
10	START		* COMPLETE	63.54
10	START	0.0	RELEASE	63.54
10	START	0.0	START	63.54
10	START		* COMPLETE	64.13
10	START	0.0	RELEASE	64.13
10	START	0.0	START	64.13
10	START		* COMPLETE	64.60
10	START	0.0	RELEASE	64.60
10	START	0.0	START	64.60
10	START		* COMPLETE	65.03
10	START	0.0	RELEASE	65.03
10	START	0.0	START	65.03
10	START		* COMPLETE	65.52
10	START	0.0	RELEASE	65.52
10	START	0.0	START	65.52
10	START		* COMPLETE	65.97
10	START	0.0	RELEASE	65.97
10	START	0.0	START	65.97
49	TURB 2		* COMPLETE	66.00
48	TURB 1	0.0	RELEASE	66.00
48	TURB 1	0.0	START	66.00
10	START		* COMPLETE	66.48
20	RESTART	0.0	RELEASE	66.48
20	RESTART	0.0	START	66.48
20	RESTART		* COMPLETE	66.48
22	DS2 UNB	0.0	RELEASE	66.48
22	DS2 UNB	0.0	START	66.48
22	DS2 UNB		* COMPLETE	66.48

36	TH11 ACC	0.0	RELEASE	66.48
36	TH11 ACC	0.0	START	66.48
36	TH11 ACC		* COMPLETE	66.48
10	START	0.0	RELEASE	66.48
10	START	0.0	START	66.48
10	START		* COMPLETE	66.97
10	START	0.0	RELEASE	66.97
10	START	0.0	START	66.97
10	START		* COMPLETE	67.66
10	START	0.0	RELEASE	67.66
10	START	0.0	START	67.66
10	START		* COMPLETE	68.23
10	START	0.0	RELEASE	68.23
10	START	0.0	START	68.23
10	START		* COMPLETE	68.80
10	START	0.0	RELEASE	68.80
10	START	0.0	START	68.80
10	START		* COMPLETE	69.34
10	START	0.0	RELEASE	69.34
10	START	0.0	START	69.34
10	START		* COMPLETE	69.97
10	START	0.0	RELEASE	69.97
10	START	0.0	START	69.97
10	START		* COMPLETE	70.65
10	START	0.0	RELEASE	70.65
10	START	0.0	START	70.65
10	START		* COMPLETE	71.16
10	START	0.0	RELEASE	71.16
10	START	0.0	START	71.16
10	START		* COMPLETE	71.82
10	START	0.0	RELEASE	71.82
10	START	0.0	START	71.82
10	START		* COMPLETE	72.36
10	START	0.0	RELEASE	72.36
10	START	0.0	START	72.36
10	START		* COMPLETE	72.85
10	START	0.0	RELEASE	72.85
10	START	0.0	START	72.85
10	START		* COMPLETE	73.16
10	START	0.0	RELEASE	73.16
10	START	0.0	START	73.16
10	START		* COMPLETE	73.69
10	START	0.0	RELEASE	73.69
10	START	0.0	START	73.69
10	START		* COMPLETE	74.29

10	START	0.0	RELEASE	74.29
10	START	0.0	START	74.29
10	START		* COMPLETE	74.83
10	START	0.0	RELEASE	74.83
10	START	0.0	START	74.83
10	START		* COMPLETE	75.20
10	START	0.0	RELEASE	75.20
10	START	0.0	START	75.20
10	START		* COMPLETE	75.80
10	START	0.0	RELEASE	75.80
10	START	0.0	START	75.80
10	START		* COMPLETE	76.19
10	START	0.0	RELEASE	76.19
10	START	0.0	START	76.19
10	START		* COMPLETE	76.68
10	START	0.0	RELEASE	76.68
10	START	0.0	START	76.68
10	START		* COMPLETE	77.16
10	START	0.0	RELEASE	77.16
10	START	0.0	START	77.16
10	START		* COMPLETE	77.74
10	START	0.0	RELEASE	77.74
10	START	0.0	START	77.74
48	TURB 1		* COMPLETE	78.00
49	TURB 2	0.0	RELEASE	78.00
49	TURB 2	0.0	START	78.00
10	START		* COMPLETE	78.13
20	RESTART	0.0	RELEASE	78.13
20	RESTART	0.0	START	78.13
20	RESTART		* COMPLETE	78.13
22	DS2 UNB	0.0	RELEASE	78.13
22	DS2 UNB	0.0	START	78.13
22	DS2 UNB		* COMPLETE	78.13
36	TH11 ACC	0.0	RELEASE	78.13
36	TH11 ACC	0.0	START	78.13
36	TH11 ACC		* COMPLETE	78.13
10	START	0.0	RELEASE	78.13
10	START	0.0	START	78.13
10	START		* COMPLETE	78.75
10	START	0.0	RELEASE	78.75
10	START	0.0	START	78.75
10	START		* COMPLETE	79.41
10	START	0.0	RELEASE	79.41
10	START	0.0	START	79.41
10	START		* COMPLETE	80.01

10	START	0.0	RELEASE	80.01
10	START	0.0	START	80.01
10	START		* COMPLETE	80.54
10	START	0.0	RELEASE	80.54
10	START	0.0	START	80.54
10	START		* COMPLETE	80.92
10	START	0.0	RELEASE	80.92
10	START	0.0	START	80.92
10	START		* COMPLETE	81.58
10	START	0.0	RELEASE	81.58
10	START	0.0	START	81.58
10	START		* COMPLETE	81.94
10	START	0.0	RELEASE	81.94
10	START	0.0	START	81.94
10	START		* COMPLETE	82.37
10	START	0.0	RELEASE	82.37
10	START	0.0	START	82.37
10	START		* COMPLETE	82.78
10	START	0.0	RELEASE	82.78
10	START	0.0	START	82.78
10	START		* COMPLETE	83.28
10	START	0.0	RELEASE	83.28
10	START	0.0	START	83.28
10	START		* COMPLETE	83.68
10	START	0.0	RELEASE	83.68
10	START	0.0	START	83.68
10	START		* COMPLETE	84.08
10	START	0.0	RELEASE	84.08
10	START	0.0	START	84.08
10	START		* COMPLETE	84.60
10	START	0.0	RELEASE	84.60
10	START	0.0	START	84.60
10	START		* COMPLETE	84.97
10	START	0.0	RELEASE	84.97
10	START	0.0	START	84.97
10	START		* COMPLETE	85.46
10	START	0.0	RELEASE	85.46
10	START	0.0	START	85.46
10	START		* COMPLETE	86.10
10	START	0.0	RELEASE	86.10
10	START	0.0	START	86.10
10	START		* COMPLETE	86.60
10	START	0.0	RELEASE	86.60
10	START	0.0	START	86.60
10	START		* COMPLETE	87.14



10	START	0.0	RELEASE	87.14
10	START	0.0	START	87.14
10	START		* COMPLETE	87.62
10	START	0.0	RELEASE	87.62
10	START	0.0	START	87.62
49	TURB 2		* COMPLETE	88.00
48	TURB 1	0.0	RELEASE	88.00
48	TURB 1	0.0	START	88.00
10	START		* COMPLETE	88.22
20	RESTART	0.0	RELEASE	88.22
20	RESTART	0.0	START	88.22
20	RESTART		* COMPLETE	88.22
22	DS2 UNB	0.0	RELEASE	88.22
22	DS2 UNB	0.0	START	88.22
22	DS2 UNB		* COMPLETE	88.22
36	TH11 ACC	0.0	RELEASE	88.22
36	TH11 ACC	0.0	START	88.22
36	TH11 ACC		* COMPLETE	88.22
10	START	0.0	RELEASE	88.22
10	START	0.0	START	88.22
10	START		* COMPLETE	88.65
10	START	0.0	RELEASE	88.65
10	START	0.0	START	88.65
10	START		* COMPLETE	89.04
10	START	0.0	RELEASE	89.04
10	START	0.0	START	89.04
10	START		* COMPLETE	89.50
10	START	0.0	RELEASE	89.50
10	START	0.0	START	89.50
10	START		* COMPLETE	90.05
10	START	0.0	RELEASE	90.05
10	START	0.0	START	90.05
10	START		* COMPLETE	90.50
10	START	0.0	RELEASE	90.50
10	START	0.0	START	90.50
10	START		* COMPLETE	91.05
10	START	0.0	RELEASE	91.05
10	START	0.0	START	91.05
10	START		* COMPLETE	91.50
10	START	0.0	RELEASE	91.50
10	START	0.0	START	91.50
10	START		* COMPLETE	92.10
10	START	0.0	RELEASE	92.10
10	START	0.0	START	92.10
10	START		* COMPLETE	92.73

10	START	0.0	RELEASE	92.73
10	START	0.0	START	92.73
10	START		* COMPLETE	93.15
10	START	0.0	RELEASE	93.15
10	START	0.0	START	93.15
10	START		* COMPLETE	93.68
10	START	0.0	RELEASE	93.68
10	START	0.0	START	93.68
10	START		* COMPLETE	94.25
10	START	0.0	RELEASE	94.25
10	START	0.0	START	94.25
10	START		* COMPLETE	94.72
10	START	0.0	RELEASE	94.72
10	START	0.0	START	94.72
10	START		* COMPLETE	95.35
10	START	0.0	RELEASE	95.35
10	START	0.0	START	95.35
10	START		* COMPLETE	95.90
10	START	0.0	RELEASE	95.90
10	START	0.0	START	95.90
10	START		* COMPLETE	96.45
10	START	0.0	RELEASE	96.45
10	START	0.0	START	96.45
10	START		* COMPLETE	97.02
10	START	0.0	RELEASE	97.02
10	START	0.0	START	97.02
10	START		* COMPLETE	97.49
10	START	0.0	RELEASE	97.49
10	START	0.0	START	97.49
10	START		* COMPLETE	98.13
10	START	0.0	RELEASE	98.13
10	START	0.0	START	98.13
10	START		* COMPLETE	98.75
10	START	0.0	RELEASE	98.75
10	START	0.0	START	98.75
10	START		* COMPLETE	99.28
10	START	0.0	RELEASE	99.28
10	START	0.0	START	99.28
10	START		* COMPLETE	99.75
10	START	0.0	RELEASE	99.75
10	START	0.0	START	99.75
48	TURB 1		* COMPLETE	100.00
49	TURB 2	0.0	RELEASE	100.00
49	TURB 2	0.0	START	100.00
10	START		* COMPLETE	100.20

20	RESTART	0.0	RELEASE	100.20
20	RESTART	0.0	START	100.20
20	RESTART		* COMPLETE	100.20
22	DS2 UNB	0.0	RELEASE	100.20
22	DS2 UNB	0.0	START	100.20
22	DS2 UNB		* COMPLETE	100.20
36	TH11 ACC	0.0	RELEASE	100.20
36	TH11 ACC	0.0	START	100.20
36	TH11 ACC		* COMPLETE	100.20
10	START	0.0	RELEASE	100.20
10	START	0.0	START	100.20
10	START		* COMPLETE	100.63
10	START	0.0	RELEASE	100.63
10	START	0.0	START	100.63
10	START		* COMPLETE	101.12
10	START	0.0	RELEASE	101.12
10	START	0.0	START	101.12
10	START		* COMPLETE	101.54
10	START	0.0	RELEASE	101.54
10	START	0.0	START	101.54
10	START		* COMPLETE	102.00
10	START	0.0	RELEASE	102.00
10	START	0.0	START	102.00
10	START		* COMPLETE	102.33
10	START	0.0	RELEASE	102.33
10	START	0.0	START	102.33
10	START		* COMPLETE	102.84
10	START	0.0	RELEASE	102.84
10	START	0.0	START	102.84
10	START		* COMPLETE	103.24
10	START	0.0	RELEASE	103.24
10	START	0.0	START	103.24
10	START		* COMPLETE	103.71
10	START	0.0	RELEASE	103.71
10	START	0.0	START	103.71
10	START		* COMPLETE	104.24
10	START	0.0	RELEASE	104.24
10	START	0.0	START	104.24
10	START		* COMPLETE	104.65
10	START	0.0	RELEASE	104.65
10	START	0.0	START	104.65
10	START		* COMPLETE	105.11
10	START	0.0	RELEASE	105.11
10	START	0.0	START	105.11
10	START		* COMPLETE	105.66

10	START	0.0	RELEASE	105.66
10	START	0.0	START	105.66
10	START		* COMPLETE	106.08
10	START	0.0	RELEASE	106.08
10	START	0.0	START	106.08
10	START		* COMPLETE	106.58
10	START	0.0	RELEASE	106.58
10	START	0.0	START	106.58
10	START		* COMPLETE	107.04
10	START	0.0	RELEASE	107.04
10	START	0.0	START	107.04
10	START		* COMPLETE	107.48
10	START	0.0	RELEASE	107.48
10	START	0.0	START	107.48
10	START		* COMPLETE	108.17
10	START	0.0	RELEASE	108.17
10	START	0.0	START	108.17
10	START		* COMPLETE	108.54
10	START	0.0	RELEASE	108.54
10	START	0.0	START	108.54
10	START		* COMPLETE	108.84
10	START	0.0	RELEASE	108.84
10	START	0.0	START	108.84
10	START		* COMPLETE	109.30
10	START	0.0	RELEASE	109.30
10	START	0.0	START	109.30
10	START		* COMPLETE	109.80
10	START	0.0	RELEASE	109.80
10	START	0.0	START	109.80
49	TURB 2		* COMPLETE	110.00
48	TURB 1	0.0	RELEASE	110.00
48	TURB 1	0.0	START	110.00
10	START		* COMPLETE	110.49
20	RESTART	0.0	RELEASE	110.49
20	RESTART	0.0	START	110.49
20	RESTART		* COMPLETE	110.49
22	DS2 UNB	0.0	RELEASE	110.49
22	DS2 UNB	0.0	START	110.49
22	DS2 UNB		* COMPLETE	110.49
36	TH11 ACC	0.0	RELEASE	110.49
36	TH11 ACC	0.0	START	110.49
36	TH11 ACC		* COMPLETE	110.49
10	START	0.0	RELEASE	110.49
10	START	0.0	START	110.49
10	START		* COMPLETE	111.10

10	START	0.0	RELEASE	111.10
10	START	0.0	START	111.10
10	START		* COMPLETE	111.43
10	START	0.0	RELEASE	111.43
10	START	0.0	START	111.43
10	START		* COMPLETE	111.94
10	START	0.0	RELEASE	111.94
10	START	0.0	START	111.94
10	START		* COMPLETE	112.44
10	START	0.0	RELEASE	112.44
10	START	0.0	START	112.44
10	START		* COMPLETE	112.97
10	START	0.0	RELEASE	112.97
10	START	0.0	START	112.97
10	START		* COMPLETE	113.32
10	START	0.0	RELEASE	113.32
10	START	0.0	START	113.32
10	START		* COMPLETE	113.84
10	START	0.0	RELEASE	113.84
10	START	0.0	START	113.84
10	START		* COMPLETE	114.38
10	START	0.0	RELEASE	114.38
10	START	0.0	START	114.38
10	START		* COMPLETE	114.87
10	START	0.0	RELEASE	114.87
10	START	0.0	START	114.87
10	START		* COMPLETE	115.35
10	START	0.0	RELEASE	115.35
10	START	0.0	START	115.35
10	START		* COMPLETE	115.89
10	START	0.0	RELEASE	115.89
10	START	0.0	START	115.89
10	START		* COMPLETE	116.22
10	START	0.0	RELEASE	116.22
10	START	0.0	START	116.22
10	START		* COMPLETE	116.88
10	START	0.0	RELEASE	116.88
10	START	0.0	START	116.88
10	START		* COMPLETE	117.27
10	START	0.0	RELEASE	117.27
10	START	0.0	START	117.27
10	START		* COMPLETE	117.83
10	START	0.0	RELEASE	117.83
10	START	0.0	START	117.83
10	START		* COMPLETE	118.29



10	START	0.0	RELEASE	118.29
10	START	0.0	START	118.29
10	START		* COMPLETE	118.82
10	START	0.0	RELEASE	118.82
10	START	0.0	START	118.82
10	START		* COMPLETE	119.42
10	START	0.0	RELEASE	119.42
10	START	0.0	START	119.42
10	START		* COMPLETE	119.97
10	START	0.0	RELEASE	119.97
10	START	0.0	START	119.97
10	START		* COMPLETE	120.48
10	START	0.0	RELEASE	120.48
10	START	0.0	START	120.48
10	START		* COMPLETE	121.05
10	START	0.0	RELEASE	121.05
10	START	0.0	START	121.05
10	START		* COMPLETE	121.57
10	START	0.0	RELEASE	121.57
10	START	0.0	START	121.57
48	TURB 1		* COMPLETE	122.00
49	TURB 2	0.0	RELEASE	122.00
49	TURB 2	0.0	START	122.00
10	START		* COMPLETE	122.04
20	RESTART	0.0	RELEASE	122.04
20	RESTART	0.0	START	122.04
20	RESTART		* COMPLETE	122.04
22	DS2 UNB	0.0	RELEASE	122.04
22	DS2 UNB	0.0	START	122.04
22	DS2 UNB		* COMPLETE	122.04
36	TH11 ACC	0.0	RELEASE	122.04
36	TH11 ACC	0.0	START	122.04
36	TH11 ACC		* COMPLETE	122.04
10	START	0.0	RELEASE	122.04
10	START	0.0	START	122.04
10	START		* COMPLETE	122.67
10	START	0.0	RELEASE	122.67
10	START	0.0	START	122.67
10	START		* COMPLETE	123.17
10	START	0.0	RELEASE	123.17
10	START	0.0	START	123.17
10	START		* COMPLETE	123.74
10	START	0.0	RELEASE	123.74
10	START	0.0	START	123.74
10	START		* COMPLETE	124.27

10	START	0.0	RELEASE	124.27
10	START	0.0	START	124.27
10	START		* COMPLETE	124.83
10	START	0.0	RELEASE	124.83
10	START	0.0	START	124.83
10	START		* COMPLETE	125.18
10	START	0.0	RELEASE	125.18
10	START	0.0	START	125.18
10	START		* COMPLETE	125.80
10	START	0.0	RELEASE	125.80
10	START	0.0	START	125.80
10	START		* COMPLETE	126.26
10	START	0.0	RELEASE	126.26
10	START	0.0	START	126.26
10	START		* COMPLETE	126.68
10	START	0.0	RELEASE	126.68
10	START	0.0	START	126.68
10	START		* COMPLETE	127.21
10	START	0.0	RELEASE	127.21
10	START	0.0	START	127.21
10	START		* COMPLETE	127.73
10	START	0.0	RELEASE	127.73
10	START	0.0	START	127.73
10	START		* COMPLETE	128.38
10	START	0.0	RELEASE	128.38
10	START	0.0	START	128.38
10	START		* COMPLETE	128.89
10	START	0.0	RELEASE	128.89
10	START	0.0	START	128.89
10	START		* COMPLETE	129.31
10	START	0.0	RELEASE	129.31
10	START	0.0	START	129.31
10	START		* COMPLETE	129.93
10	START	0.0	RELEASE	129.93
10	START	0.0	START	129.93
10	START		* COMPLETE	130.49
10	START	0.0	RELEASE	130.49
10	START	0.0	START	130.49
10	START		* COMPLETE	130.91
10	START	0.0	RELEASE	130.91
10	START	0.0	START	130.91
10	START		* COMPLETE	131.49
10	START	0.0	RELEASE	131.49
10	START	0.0	START	131.49
10	START		* COMPLETE	131.95

10	START	0.0	RELEASE	131.95
10	START	0.0	START	131.95
49	TURB 2		* COMPLETE	132.00
48	TURB 1	0.0	RELEASE	132.00
48	TURB 1	0.0	START	132.00
10	START		* COMPLETE	132.60
20	RESTART	0.0	RELEASE	132.60
20	RESTART	0.0	START	132.60
20	RESTART		* COMPLETE	132.60
22	DS2 UNB	0.0	RELEASE	132.60
22	DS2 UNB	0.0	START	132.60
22	DS2 UNB		* COMPLETE	132.60
36	TH11 ACC	0.0	RELEASE	132.60
36	TH11 ACC	0.0	START	132.60
36	TH11 ACC		* COMPLETE	132.60
10	START	0.0	RELEASE	132.60
10	START	0.0	START	132.60
10	START		* COMPLETE	133.11
10	START	0.0	RELEASE	133.11
10	START	0.0	START	133.11
10	START		* COMPLETE	133.56
10	START	0.0	RELEASE	133.56
10	START	0.0	START	133.56
10	START		* COMPLETE	134.08
10	START	0.0	RELEASE	134.08
10	START	0.0	START	134.08
10	START		* COMPLETE	134.46
10	START	0.0	RELEASE	134.46
10	START	0.0	START	134.46
10	START		* COMPLETE	134.97
10	START	0.0	RELEASE	134.97
10	START	0.0	START	134.97
10	START		* COMPLETE	135.55
10	START	0.0	RELEASE	135.55
10	START	0.0	START	135.55
10	START		* COMPLETE	136.14
10	START	0.0	RELEASE	136.14
10	START	0.0	START	136.14
10	START		* COMPLETE	136.68
10	START	0.0	RELEASE	136.68
10	START	0.0	START	136.68
10	START		* COMPLETE	137.15
10	START	0.0	RELEASE	137.15
10	START	0.0	START	137.15
10	START		* COMPLETE	137.72

10	START	0.0	RELEASE	137.72
10	START	0.0	START	137.72
10	START		* COMPLETE	138.16
10	START	0.0	RELEASE	138.16
10	START	0.0	START	138.16
10	START		* COMPLETE	138.90
10	START	0.0	RELEASE	138.90
10	START	0.0	START	138.90
10	START		* COMPLETE	139.29
10	START	0.0	RELEASE	139.29
10	START	0.0	START	139.29
10	START		* COMPLETE	139.68
10	START	0.0	RELEASE	139.68
10	START	0.0	START	139.68
10	START		* COMPLETE	140.20
10	START	0.0	RELEASE	140.20
10	START	0.0	START	140.20
10	START		* COMPLETE	140.57
10	START	0.0	RELEASE	140.57
10	START	0.0	START	140.57
10	START		* COMPLETE	140.91
10	START	0.0	RELEASE	140.91
10	START	0.0	START	140.91
10	START		* COMPLETE	141.35
10	START	0.0	RELEASE	141.35
10	START	0.0	START	141.35
10	START		* COMPLETE	141.90
10	START	0.0	RELEASE	141.90
10	START	0.0	START	141.90
10	START		* COMPLETE	142.38
10	START	0.0	RELEASE	142.38
10	START	0.0	START	142.38
10	START		* COMPLETE	142.90
10	START	0.0	RELEASE	142.90
10	START	0.0	START	142.90
10	START		* COMPLETE	143.65
10	START	0.0	RELEASE	143.65
10	START	0.0	START	143.65
48	TURB 1		* COMPLETE	144.00
49	TURB 2	0.0	RELEASE	144.00
49	TURB 2	0.0	START	144.00
10	START		* COMPLETE	144.01
20	RESTART	0.0	RELEASE	144.01
20	RESTART	0.0	START	144.01
20	RESTART		* COMPLETE	144.01

22	DS2 UNB	0.0	RELEASE	144.01
22	DS2 UNB	0.0	START	144.01
22	DS2 UNB		* COMPLETE	144.01
36	TH11 ACC	0.0	RELEASE	144.01
36	TH11 ACC	0.0	START	144.01
36	TH11 ACC		* COMPLETE	144.01
10	START	0.0	RELEASE	144.01
10	START	0.0	START	144.01
10	START		* COMPLETE	144.43
10	START	0.0	RELEASE	144.43
10	START	0.0	START	144.43
10	START		* COMPLETE	144.88
10	START	0.0	RELEASE	144.88
10	START	0.0	START	144.88
10	START		* COMPLETE	145.35
10	START	0.0	RELEASE	145.35
10	START	0.0	START	145.35
10	START		* COMPLETE	145.78
10	START	0.0	RELEASE	145.78
10	START	0.0	START	145.78
10	START		* COMPLETE	146.38
10	START	0.0	RELEASE	146.38
10	START	0.0	START	146.38
10	START		* COMPLETE	147.17
10	START	0.0	RELEASE	147.17
10	START	0.0	START	147.17
10	START		* COMPLETE	147.78
10	START	0.0	RELEASE	147.78
10	START	0.0	START	147.78
10	START		* COMPLETE	148.10
10	START	0.0	RELEASE	148.10
10	START	0.0	START	148.10
10	START		* COMPLETE	148.55
10	START	0.0	RELEASE	148.55
10	START	0.0	START	148.55
10	START		* COMPLETE	149.19
10	START	0.0	RELEASE	149.19
10	START	0.0	START	149.19
10	START		* COMPLETE	149.65
10	START	0.0	RELEASE	149.65
10	START	0.0	START	149.65
10	START		* COMPLETE	150.26
10	START	0.0	RELEASE	150.26
10	START	0.0	START	150.26
10	START		* COMPLETE	150.69



10	START	0.0	RELEASE	150.69
10	START	0.0	START	150.69
10	START		* COMPLETE	151.19
10	START	0.0	RELEASE	151.19
10	START	0.0	START	151.19
10	START		* COMPLETE	151.80
10	START	0.0	RELEASE	151.80
10	START	0.0	START	151.80
10	START		* COMPLETE	152.21
10	START	0.0	RELEASE	152.21
10	START	0.0	START	152.21
10	START		* COMPLETE	152.64
10	START	0.0	RELEASE	152.64
10	START	0.0	START	152.64
10	START		* COMPLETE	152.98
10	START	0.0	RELEASE	152.98
10	START	0.0	START	152.98
10	START		* COMPLETE	153.38
10	START	0.0	RELEASE	153.38
10	START	0.0	START	153.38
10	START		* COMPLETE	153.84
10	START	0.0	RELEASE	153.84
10	START	0.0	START	153.84
49	TURB 2		* COMPLETE	154.00
48	TURB 1	0.0	RELEASE	154.00
48	TURB 1	0.0	START	154.00
10	START		* COMPLETE	154.33
20	RESTART	0.0	RELEASE	154.33
20	RESTART	0.0	START	154.33
20	RESTART		* COMPLETE	154.33
22	DS2 UNB	0.0	RELEASE	154.33
22	DS2 UNB	0.0	START	154.33
22	DS2 UNB		* COMPLETE	154.33
36	TH11 ACC	0.0	RELEASE	154.33
36	TH11 ACC	0.0	START	154.33
36	TH11 ACC		* COMPLETE	154.33
10	START	0.0	RELEASE	154.33
10	START	0.0	START	154.33
10	START		* COMPLETE	154.85
10	START	0.0	RELEASE	154.85
10	START	0.0	START	154.85
10	START		* COMPLETE	155.44
10	START	0.0	RELEASE	155.44
10	START	0.0	START	155.44
10	START		* COMPLETE	155.88

10	START	0.0	RELEASE	155.88
10	START	0.0	START	155.88
10	START		* COMPLETE	156.43
10	START	0.0	RELEASE	156.43
10	START	0.0	START	156.43
10	START		* COMPLETE	156.90
10	START	0.0	RELEASE	156.90
10	START	0.0	START	156.90
10	START		* COMPLETE	157.30
10	START	0.0	RELEASE	157.30
10	START	0.0	START	157.30
10	START		* COMPLETE	157.83
10	START	0.0	RELEASE	157.83
10	START	0.0	START	157.83
10	START		* COMPLETE	158.34
10	START	0.0	RELEASE	158.34
10	START	0.0	START	158.34
10	START		* COMPLETE	158.77
10	START	0.0	RELEASE	158.77
10	START	0.0	START	158.77
10	START		* COMPLETE	159.09
10	START	0.0	RELEASE	159.09
10	START	0.0	START	159.09
10	START		* COMPLETE	159.49
10	START	0.0	RELEASE	159.49
10	START	0.0	START	159.49
10	START		* COMPLETE	159.95
10	START	0.0	RELEASE	159.95
10	START	0.0	START	159.95
10	START		* COMPLETE	160.54
10	START	0.0	RELEASE	160.54
10	START	0.0	START	160.54
10	START		* COMPLETE	160.98
10	START	0.0	RELEASE	160.98
10	START	0.0	START	160.98
10	START		* COMPLETE	161.47
10	START	0.0	RELEASE	161.47
10	START	0.0	START	161.47
10	START		* COMPLETE	161.96
10	START	0.0	RELEASE	161.96
10	START	0.0	START	161.96
10	START		* COMPLETE	162.39
10	START	0.0	RELEASE	162.39
10	START	0.0	START	162.39
10	START		* COMPLETE	163.01

10	START	0.0	RELEASE	163.01
10	START	0.0	START	163.01
10	START		* COMPLETE	163.43
10	START	0.0	RELEASE	163.43
10	START	0.0	START	163.43
10	START		* COMPLETE	163.69
10	START	0.0	RELEASE	163.69
10	START	0.0	START	163.69
10	START		* COMPLETE	164.09
10	START	0.0	RELEASE	164.09
10	START	0.0	START	164.09
10	START		* COMPLETE	164.71
10	START	0.0	RELEASE	164.71
10	START	0.0	START	164.71
10	START		* COMPLETE	165.21
10	START	0.0	RELEASE	165.21
10	START	0.0	START	165.21
10	START		* COMPLETE	165.68
10	START	0.0	RELEASE	165.68
10	START	0.0	START	165.68
48	TURB 1		* COMPLETE	166.00
49	TURB 2	0.0	RELEASE	166.00
49	TURB 2	0.0	START	166.00
10	START		* COMPLETE	166.27
20	RESTART	0.0	RELEASE	166.27
20	RESTART	0.0	START	166.27
20	RESTART		* COMPLETE	166.27
22	DS2 UNB	0.0	RELEASE	166.27
22	DS2 UNB	0.0	START	166.27
22	DS2 UNB		* COMPLETE	166.27
36	TH11 ACC	0.0	RELEASE	166.27
36	TH11 ACC	0.0	START	166.27
36	TH11 ACC		* COMPLETE	166.27
10	START	0.0	RELEASE	166.27
10	START	0.0	START	166.27
10	START		* COMPLETE	166.92
10	START	0.0	RELEASE	166.92
10	START	0.0	START	166.92
10	START		* COMPLETE	167.53
10	START	0.0	RELEASE	167.53
10	START	0.0	START	167.53
10	START		* COMPLETE	168.00
10	START	0.0	RELEASE	168.00
10	START	0.0	START	168.00
10	START		* COMPLETE	168.47

10	START	0.0	RELEASE	168.47
10	START	0.0	START	168.47
10	START		* COMPLETE	168.91
10	START	0.0	RELEASE	168.91
10	START	0.0	START	168.91
10	START		* COMPLETE	169.42
10	START	0.0	RELEASE	169.42
10	START	0.0	START	169.42
10	START		* COMPLETE	169.79
10	START	0.0	RELEASE	169.79
10	START	0.0	START	169.79
10	START		* COMPLETE	170.37
10	START	0.0	RELEASE	170.37
10	START	0.0	START	170.37
10	START		* COMPLETE	170.73
10	START	0.0	RELEASE	170.73
10	START	0.0	START	170.73
10	START		* COMPLETE	171.09
10	START	0.0	RELEASE	171.09
10	START	0.0	START	171.09
10	START		* COMPLETE	171.51
10	START	0.0	RELEASE	171.51
10	START	0.0	START	171.51
10	START		* COMPLETE	172.12
10	START	0.0	RELEASE	172.12
10	START	0.0	START	172.12
10	START		* COMPLETE	172.50
10	START	0.0	RELEASE	172.50
10	START	0.0	START	172.50
10	START		* COMPLETE	172.99
10	START	0.0	RELEASE	172.99
10	START	0.0	START	172.99
10	START		* COMPLETE	173.49
10	START	0.0	RELEASE	173.49
10	START	0.0	START	173.49
10	START		* COMPLETE	174.00
10	START	0.0	RELEASE	174.00
10	START	0.0	START	174.00
10	START		* COMPLETE	174.48
10	START	0.0	RELEASE	174.48
10	START	0.0	START	174.48
10	START		* COMPLETE	175.08
10	START	0.0	RELEASE	175.08
10	START	0.0	START	175.08
10	START		* COMPLETE	175.62

10	START	0.0	RELEASE	175.62
10	START	0.0	START	175.62
10	START		* COMPLETE	175.98
10	START	0.0	RELEASE	175.98
10	START	0.0	START	175.98
49	TURB 2		* COMPLETE	176.00
48	TURB 1	0.0	RELEASE	176.00
48	TURB 1	0.0	START	176.00
10	START		* COMPLETE	176.35
20	RESTART	0.0	RELEASE	176.35
20	RESTART	0.0	START	176.35
20	RESTART		* COMPLETE	176.35
22	DS2 UNB	0.0	RELEASE	176.35
22	DS2 UNB	0.0	START	176.35
22	DS2 UNB		* COMPLETE	176.35
36	TH11 ACC	0.0	RELEASE	176.35
36	TH11 ACC	0.0	START	176.35
36	TH11 ACC		* COMPLETE	176.35
10	START	0.0	RELEASE	176.35
10	START	0.0	START	176.35
10	START		* COMPLETE	176.83
10	START	0.0	RELEASE	176.83
10	START	0.0	START	176.83
10	START		* COMPLETE	177.21
10	START	0.0	RELEASE	177.21
10	START	0.0	START	177.21
10	START		* COMPLETE	177.57
10	START	0.0	RELEASE	177.57
10	START	0.0	START	177.57
10	START		* COMPLETE	178.14
10	START	0.0	RELEASE	178.14
10	START	0.0	START	178.14
10	START		* COMPLETE	178.66
10	START	0.0	RELEASE	178.66
10	START	0.0	START	178.66
10	START		* COMPLETE	179.18
10	START	0.0	RELEASE	179.18
10	START	0.0	START	179.18
10	START		* COMPLETE	179.63
10	START	0.0	RELEASE	179.63
10	START	0.0	START	179.63
10	START		* COMPLETE	180.10
10	START	0.0	RELEASE	180.10
10	START	0.0	START	180.10
10	START		* COMPLETE	180.76



10	START	0.0	RELEASE	180.76
10	START	0.0	START	180.76
10	START		* COMPLETE	181.21
10	START	0.0	RELEASE	181.21
10	START	0.0	START	181.21
10	START		* COMPLETE	181.61
10	START	0.0	RELEASE	181.61
10	START	0.0	START	181.61
10	START		* COMPLETE	182.18
10	START	0.0	RELEASE	182.18
10	START	0.0	START	182.18
10	START		* COMPLETE	182.71
10	START	0.0	RELEASE	182.71
10	START	0.0	START	182.71
10	START		* COMPLETE	183.25
10	START	0.0	RELEASE	183.25
10	START	0.0	START	183.25
10	START		* COMPLETE	183.66
10	START	0.0	RELEASE	183.66
10	START	0.0	START	183.66
10	START		* COMPLETE	184.16
10	START	0.0	RELEASE	184.16
10	START	0.0	START	184.16
10	START		* COMPLETE	184.73
10	START	0.0	RELEASE	184.73
10	START	0.0	START	184.73
10	START		* COMPLETE	185.35
10	START	0.0	RELEASE	185.35
10	START	0.0	START	185.35
10	START		* COMPLETE	185.77
10	START	0.0	RELEASE	185.77
10	START	0.0	START	185.77
10	START		* COMPLETE	186.30
10	START	0.0	RELEASE	186.30
10	START	0.0	START	186.30
10	START		* COMPLETE	186.85
10	START	0.0	RELEASE	186.85
10	START	0.0	START	186.85
10	START		* COMPLETE	187.49
10	START	0.0	RELEASE	187.49
10	START	0.0	START	187.49
10	START		* COMPLETE	187.98
10	START	0.0	RELEASE	187.98
10	START	0.0	START	187.98
48	TURB 1		* COMPLETE	188.00

49	TURB 2	0.0	RELEASE	188.00
49	TURB 2	0.0	START	188.00
10	START		* COMPLETE	188.43
20	RESTART	0.0	RELEASE	188.43
20	RESTART	0.0	START	188.43
20	RESTART		* COMPLETE	188.43
22	DS2 UNB	0.0	RELEASE	188.43
22	DS2 UNB	0.0	START	188.43
22	DS2 UNB		* COMPLETE	188.43
36	TH11 ACC	0.0	RELEASE	188.43
36	TH11 ACC	0.0	START	188.43
36	TH11 ACC		* COMPLETE	188.43
10	START	0.0	RELEASE	188.43
10	START	0.0	START	188.43
10	START		* COMPLETE	189.00
10	START	0.0	RELEASE	189.00
10	START	0.0	START	189.00
10	START		* COMPLETE	189.51
10	START	0.0	RELEASE	189.51
10	START	0.0	START	189.51
10	START		* COMPLETE	190.12
10	START	0.0	RELEASE	190.12
10	START	0.0	START	190.12
10	START		* COMPLETE	190.51
10	START	0.0	RELEASE	190.51
10	START	0.0	START	190.51
10	START		* COMPLETE	191.00
10	START	0.0	RELEASE	191.00
10	START	0.0	START	191.00
10	START		* COMPLETE	191.50
10	START	0.0	RELEASE	191.50
10	START	0.0	START	191.50
10	START		* COMPLETE	191.81
10	START	0.0	RELEASE	191.81
10	START	0.0	START	191.81
10	START		* COMPLETE	192.23
10	START	0.0	RELEASE	192.23
10	START	0.0	START	192.23
10	START		* COMPLETE	192.77
10	START	0.0	RELEASE	192.77
10	START	0.0	START	192.77
10	START		* COMPLETE	193.19
10	START	0.0	RELEASE	193.19
10	START	0.0	START	193.19
10	START		* COMPLETE	193.64

10	START	0.0	RELEASE	193.64
10	START	0.0	START	193.64
10	START		* COMPLETE	194.24
10	START	0.0	RELEASE	194.24
10	START	0.0	START	194.24
10	START		* COMPLETE	194.69
10	START	0.0	RELEASE	194.69
10	START	0.0	START	194.69
10	START		* COMPLETE	195.41
10	START	0.0	RELEASE	195.41
10	START	0.0	START	195.41
10	START		* COMPLETE	195.81
10	START	0.0	RELEASE	195.81
10	START	0.0	START	195.81
10	START		* COMPLETE	196.30
10	START	0.0	RELEASE	196.30
10	START	0.0	START	196.30
10	START		* COMPLETE	196.72
10	START	0.0	RELEASE	196.72
10	START	0.0	START	196.72
10	START		* COMPLETE	197.13
10	START	0.0	RELEASE	197.13
10	START	0.0	START	197.13
10	START		* COMPLETE	197.65
10	START	0.0	RELEASE	197.65
10	START	0.0	START	197.65
49	TURB 2		* COMPLETE	198.00
48	TURB 1	0.0	RELEASE	198.00
48	TURB 1	0.0	START	198.00
10	START		* COMPLETE	198.16
20	RESTART	0.0	RELEASE	198.16
20	RESTART	0.0	START	198.16
20	RESTART		* COMPLETE	198.16
22	DS2 UNB	0.0	RELEASE	198.16
22	DS2 UNB	0.0	START	198.16
22	DS2 UNB		* COMPLETE	198.16
36	TH11 ACC	0.0	RELEASE	198.16
36	TH11 ACC	0.0	START	198.16
36	TH11 ACC		* COMPLETE	198.16
10	START	0.0	RELEASE	198.16
10	START	0.0	START	198.16
10	START		* COMPLETE	198.69
10	START	0.0	RELEASE	198.69
10	START	0.0	START	198.69
10	START		* COMPLETE	199.13

10	START	0.0	RELEASE	199.13
10	START	0.0	START	199.13
10	START		* COMPLETE	199.65
10	START	0.0	RELEASE	199.65
10	START	0.0	START	199.65
10	START		* COMPLETE	200.01
10	START	0.0	RELEASE	200.01
10	START	0.0	START	200.01
10	START		* COMPLETE	200.38
10	START	0.0	RELEASE	200.38
10	START	0.0	START	200.38
10	START		* COMPLETE	201.07
10	START	0.0	RELEASE	201.07
10	START	0.0	START	201.07
10	START		* COMPLETE	201.67
10	START	0.0	RELEASE	201.67
10	START	0.0	START	201.67
10	START		* COMPLETE	202.12
10	START	0.0	RELEASE	202.12
10	START	0.0	START	202.12
10	START		* COMPLETE	202.68
10	START	0.0	RELEASE	202.68
10	START	0.0	START	202.68
10	START		* COMPLETE	203.12
10	START	0.0	RELEASE	203.12
10	START	0.0	START	203.12
10	START		* COMPLETE	203.49
10	START	0.0	RELEASE	203.49
10	START	0.0	START	203.49
10	START		* COMPLETE	203.84
10	START	0.0	RELEASE	203.84
10	START	0.0	START	203.84
10	START		* COMPLETE	204.18
10	START	0.0	RELEASE	204.18
10	START	0.0	START	204.18
10	START		* COMPLETE	204.65
10	START	0.0	RELEASE	204.65
10	START	0.0	START	204.65
10	START		* COMPLETE	205.13
10	START	0.0	RELEASE	205.13
10	START	0.0	START	205.13
10	START		* COMPLETE	205.62
10	START	0.0	RELEASE	205.62
10	START	0.0	START	205.62
10	START		* COMPLETE	206.16

10	START	0.0	RELEASE	206.16
10	START	0.0	START	206.16
10	START		* COMPLETE	206.76
10	START	0.0	RELEASE	206.76
10	START	0.0	START	206.76
10	START		* COMPLETE	207.26
10	START	0.0	RELEASE	207.26
10	START	0.0	START	207.26
10	START		* COMPLETE	207.98
10	START	0.0	RELEASE	207.98
10	START	0.0	START	207.98
10	START		* COMPLETE	208.50
10	START	0.0	RELEASE	208.50
10	START	0.0	START	208.50
10	START		* COMPLETE	208.87
10	START	0.0	RELEASE	208.87
10	START	0.0	START	208.87
10	START		* COMPLETE	209.41
10	START	0.0	RELEASE	209.41
10	START	0.0	START	209.41
10	START		* COMPLETE	209.88
10	START	0.0	RELEASE	209.88
10	START	0.0	START	209.88
48	TURB 1		* COMPLETE	210.00
49	TURB 2	0.0	RELEASE	210.00
49	TURB 2	0.0	START	210.00
10	START		* COMPLETE	210.24
20	RESTART	0.0	RELEASE	210.24
20	RESTART	0.0	START	210.24
20	RESTART		* COMPLETE	210.24
22	DS2 UNB	0.0	RELEASE	210.24
22	DS2 UNB	0.0	START	210.24
22	DS2 UNB		* COMPLETE	210.24
36	TH11 ACC	0.0	RELEASE	210.24
36	TH11 ACC	0.0	START	210.24
36	TH11 ACC		* COMPLETE	210.24
10	START	0.0	RELEASE	210.24
10	START	0.0	START	210.24
10	START		* COMPLETE	210.72
10	START	0.0	RELEASE	210.72
10	START	0.0	START	210.72
10	START		* COMPLETE	211.16
10	START	0.0	RELEASE	211.16
10	START	0.0	START	211.16
10	START		* COMPLETE	211.66



10	START	0.0	RELEASE	211.66
10	START	0.0	START	211.66
10	START		* COMPLETE	212.10
10	START	0.0	RELEASE	212.10
10	START	0.0	START	212.10
10	START		* COMPLETE	212.42
10	START	0.0	RELEASE	212.42
10	START	0.0	START	212.42
10	START		* COMPLETE	212.99
10	START	0.0	RELEASE	212.99
10	START	0.0	START	212.99
10	START		* COMPLETE	213.41
10	START	0.0	RELEASE	213.41
10	START	0.0	START	213.41
10	START		* COMPLETE	214.07
10	START	0.0	RELEASE	214.07
10	START	0.0	START	214.07
10	START		* COMPLETE	214.62
10	START	0.0	RELEASE	214.62
10	START	0.0	START	214.62
10	START		* COMPLETE	215.05
10	START	0.0	RELEASE	215.05
10	START	0.0	START	215.05
10	START		* COMPLETE	215.61
10	START	0.0	RELEASE	215.61
10	START	0.0	START	215.61
10	START		* COMPLETE	216.27
10	START	0.0	RELEASE	216.27
10	START	0.0	START	216.27
10	START		* COMPLETE	216.91
10	START	0.0	RELEASE	216.91
10	START	0.0	START	216.91
10	START		* COMPLETE	217.37
10	START	0.0	RELEASE	217.37
10	START	0.0	START	217.37
10	START		* COMPLETE	217.86
10	START	0.0	RELEASE	217.86
10	START	0.0	START	217.86
10	START		* COMPLETE	218.39
10	START	0.0	RELEASE	218.39
10	START	0.0	START	218.39
10	START		* COMPLETE	218.99
10	START	0.0	RELEASE	218.99
10	START	0.0	START	218.99
10	START		* COMPLETE	219.48

10	START	0.0	RELEASE	219.48
10	START	0.0	START	219.48
10	START		* COMPLETE	219.89
10	START	0.0	RELEASE	219.89
10	START	0.0	START	219.89
49	TURB 2		* COMPLETE	220.00
48	TURB 1	0.0	RELEASE	220.00
50	STOP	0.0	RELEASE	220.00
48	TURB 1	0.0	START	220.00
50	STOP	0.0	START	220.00
50	STGP		* COMPLETE	220.00