

Effective communication through form manipulation

by

Juan Manuel Gomez Pavon

A Thesis Submitted to the
Graduate Faculty in Partial Fulfillment of the
Requirements for the Degree of
MASTER OF ARTS

Department: Art and Design
Major: Art and Design (Specialization: Graphic Design)

Signatures have been redacted for privacy

Iowa State University

Ames, Iowa

1991

TABLE OF CONTENTS

	Page
INTRODUCTION	1
LITERATURE REVIEW	4
Overview and Definition of the Topic	4
Roots: Key Movements that Influenced Graphic Design	7
Art for art's sake vs. art for society	7
Visual language: pictographs, photos, symbols, signs	40
Isotype Movement	40
Signs and graphic language	42
Technical Communication	44
Types of languages	45
Technical writing	49
Formats for technical manuals	54
Summary and Conclusions	62
Technical Manuals Review and Evaluation	67
Creation of a matrix	67
INTRODUCTION TO THE PROJECT	78
Redesign of the Sony Manual	80
Specifications and justifications	88
CONCLUSIONS	98
BIBLIOGRAPHY	101

INTRODUCTION

Traditionally, graphic design was inspired by painting and other art disciplines, even sharing a common vocabulary in some historical periods. Graphic design expresses its unique role in communication by its ability to convey visual and verbal information by the use of vitality and order. Great works of graphic design possess this balance and therefore communicate clearly and powerfully. The work of great designers such as Jan Tschichold, Herbert Bayer, and Laszlo Moholy-Nagy, among others, demonstrates the effective use of vitality and order. Graphic design should be the product of the analysis of a message and the careful adjustment of elements and different relationships among them, in this particular study vitality, order, and legibility are to be considered very important because they are imbedded in all graphic design.

Vitality gives visual excitement to graphic elements through the use of asymmetric layout, varied typography (weights, sizes, styles), and contrast of image and type. Order brings functionalism to the whole composition through a consistent use of an organizing structure and by a repeating typographic format. Legibility in typography refers to the kind of type used, its size, width of its lines, leading of lines, and the size of the margins in order to be most easily understood. Using such elements, including signs, symbols, words and pictures, graphic design is able to create visual forms that are the best possible solutions for a given graphic problem.

With the arrival of the computer in the late 1970s, new efforts were undertaken by graphic designers relating to the ways images could be created and manipulated. Graphic designers have been integrating new technologies to strengthen the representation of ideas in visual communication since the industrial revolution. Based on a combination of new

technology and traditional concepts, contemporary approaches to graphic design are more precise and at the same time more expressive than in the past. Vitality as well as order still play critical roles in the generation of mass communication. In a competitive electronic world, printed media must reinforce the graphic components of electronics using vitality to make the information noticeable and order to clearly communicate the message.

This study briefly reviews the development of graphic communication from the time when it shared styles with the fine arts to the arrival of objective design in the late 1950's. There are key styles and movements that were sources of inspiration for the typographic designers who saw new ways of representing spatial relations, shapes, colors and textures in their own work. Some of these movements contributed directly to graphic design with the development of new techniques such as collages, photomontages, and photograms; others influenced the ways of displaying elements, creating visual vitality among graphic elements; and still others defined the use of visual order, clarity, and functionalism. As a result, the way typographic designers use graphic elements was changed forever. This study then reviews some aspects of technical manuals in terms of graphic communication, and thereby examines the factors which are involved in the production of technical mass communication materials.

The final outcome of this study is to enable exploration and development of effective technical manuals based on research concerning communication of technical information using the computer as a major tool. The project is aimed at redesigning three sections and the cover of the technical manual for the Sony SLV-70 HF home video recorder. The exploration of some possible graphic solutions for this technical manual involve the following sections: Features, Precautions, Recording TV Programs, and its cover. Standards that will improve the interface and efficient use of a technical manual are applied

to the new design. The graphic solutions presented in this thesis incorporate communication standards and knowledge obtained through appropriate literature review.

A technical manual serves as the interface between user and technology. As such it must possess order for clarity of communication and vitality for stimulating interest and visually reinforcing the message.

LITERATURE REVIEW

Overview and Definition of the Topic

Effective Communication Through Form Manipulation refers to the ability to handle visual elements appropriately on a printed page. The combination of visual signs, symbols, and images in a visual-textual composition establishes a message; these graphic elements can be manipulated in endless ways. Each element has its own qualities and properties.

An image on a printed page is a symbolic representation of something or someone; the technique of representation could be photography, illustration, painting, drawing, or sketching. The decision to choose one of these techniques depends on the designer's intention. Every technique has its own properties and limitations. For example, photography possesses good representational quality, reflecting a life-like reality, either in color or in black and white. But it cannot be as precise as an outline drawing showing only the most essential outward form of a structure, as in technical construction plans or in the case of a diagram which shows a cross-section of a machine in order to explain its function.

An image has its own vocabulary and can convey anything from simple messages to deep feelings. A realistic photograph of a countryside may create a pleasant feeling in the viewer; a photograph of a war camp depicting the disasters of war may envelop the viewer in the most profound thoughts on the human condition. Though images on printed pages commonly enhance and reinforce the meaning of the text, sometimes the combination of both creates a new meaning (Meggs, 1989).

Text is a group of signs derived from non-objective abstractions; it must be learned in order to understand it and communicate with it. Different from images, which can be

interpreted in different ways, text transmits specific meanings manipulated by the author's ideas. When text guides the reader to an explicit and singular message, subjective interpretation is not possible — as in the case of operating instructions or technical manuals in which precise commands are requested — for example, “do not remove cover” or “insert a cassette.”

Titles, captions, and text each have different interactions with images. A title often has the same importance as the image; if they have the same message, a visual-verbal redundancy results, and the total message is reinforced — such as in automotive advertising in newspapers or magazines in which the car's name is the title and its image is shown. On the other hand, captions have a subordinate role; placed close to the image they describe, captions provide extra information, description, or identification of an image. Text has an informative content role. Usually its relationship with images is indicated by location; images may describe the events, things, or people in the text, eye-catchers of the description. The conventional relationship of text and image is that each has its own space, and each communicates its message without the other's interference (Meggs, 1989).

Often an exciting and unexpected way to combine text and image is by juxtaposing them. Type is overprinted or reversed on the image to create a strong message, visual hierarchy, and effective communication. Size, position, and value contrast are critical elements in this kind of combination because readability can be either damaged or enhanced (Meggs, 1989). In addition, a cause-and-effect relationship can be established between type and image juxtaposition — such as in magazine cover photography in which the image and the main title usually have strong relationships. If the title describes information unrelated to the image, a new message could result, because our minds juxtapose the two messages and try to make a connection.

Effective Communication Through Form Manipulation has an extended range of application. It could be applied to any graphic problem such as posters, brochures, or books. Because the elements used by these kinds of communications are similar (*type, symbols, signs, and images*), composition, contrast, color, and rhythm can be applied to each of them.

Technical manuals are publications primarily concerned with communicating precise information — procedures, methods, reports, directions, and instructions. Since the user of technical manuals looks for explicit information, the technical writing demands specific skills and knowledge in order to make its instructions understandable. The use of pre-determined writing formats improves the transmission efficiency of new information to the user. At the same time, technical images require specific qualities for easier and more understandable communication.

Technical manuals are specialized forms of graphic communication in which skilled writing and appropriate images are required. The elements included in this kind of graphic design are type, signs, symbols, and images which must be focused to produce a clear and easy vehicle for specific information in technical manuals. The ability of the technical writer as well as the graphic designer must be concentrated on this goal.

Roots: Key Movements that Influenced Graphic Design

Art for art's sake vs. art for society

The way that we see graphic communication today is based on the changes which occurred in the first decades of this century. The transformation occurred first in fine arts beginning with the representational approach of the traditional artists which gave way to the abstract nonobjective direction of the Avant Garde artists of this century. The next step was to provide this art with a social attitude. Painting suffered a new change; the efforts of talented artists were focused on the community necessities of mass production and communication (Gottschall, 1989).

The change was developed in Russia following the revolution of 1917. "A deep ideological split developed concerning the role of the artist in the new communist state," (Meggs, 1983, p. 312). Constructivists drew attention all over the world with their new attitude toward art because of its social connotations. Artistic efforts took a new direction for society focusing on industrial and graphic design for mass production. This and other movements and schools that followed (such as the De Stijl and the Bauhaus) were fundamental to making graphic design what it is today, changing an attitude of "Art for Art's sake" to "Art for Society" (Gottschall, 1989).

From Traditionalism to Abstractionist The objectivity that was a characteristic of the painting artists during the 15th to the 19th centuries was broken during the mid 19th century when church and state patronage of the arts declined. Painters then started to work in a subjective way, more experimental than their predecessors (Gottschall, 1989). Artists like Jean-Baptiste Camille Corot (1796-1875) and Jean Francois Millet (1814-1875) changed the true-to-life manner to a more personal view point.

Years earlier, the English painters John Constable (1776-1837) and Joseph Mallord William Turner (1775-1851) had worked in a subjective way in their landscapes — called at that time a “romantic touch”; we can consider that they broke, in a slight way, with traditional representational painting (Gottshall, 1989).

Impressionism By the 1870’s painters became more subjective in the manner of representing life. Claude Monet (1840-1926), Camille Pissarro (1830-1930), and Pierre August Renoir (1841-1919) were some of the most prominent French Impressionists who implied feelings in their representations. Monet’s landscapes, for example, show how he felt about the scene. For him, a painting was no longer merely a scene recorder. He painted his personal feelings, not just representations. A new way to see landscapes was the major contribution of the French Impressionists in breaking with centuries-old traditional concepts (Figure 1). After Constable, the impressionists were the second important step in the transformation of traditional painting (Gottschall, 1989).

Renoir, Pissarro, Manet, and Monet were the first impressionists who used their brushes in a more free way than their contemporaries. They added strokes and random spots of color to their works, looking for an overall harmony in their compositions. These artists focused on patterns, colors, and light effects. They modified the subject in order to express a certain definite mood. Effects of light and color, intended to create brilliance and luminosity, were important considerations, as well as the use of asymmetrical composition and two or more perspectives in the same work (Gottshall, 1989).

At that time their work was rejected by French society; in 1873, “The Official Salon” denied them access to its exhibition. The next year they organized their own show as a group, calling themselves “*Société Anonyme Des Artistes, Peintres, Graveurs, Sculpteurs.*” They held eight exhibitions from 1874-1886. In 1872, one critic called them

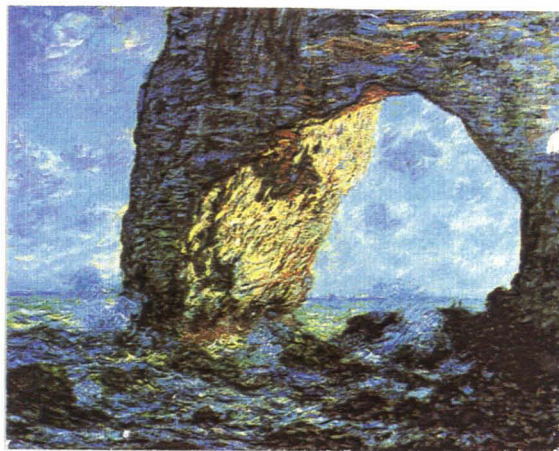
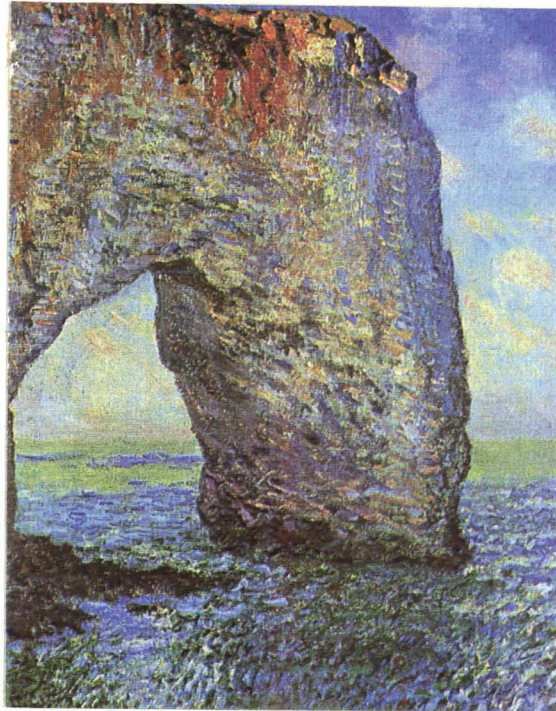

Figure 1. Claude Monet. *The Manneport, Etretat I and II*, 1913 and 1951

“Impressionists” (as a denigrating term), after seeing Monet’s “Impression: Sunrise” a seascape (Kelder, 1978). Monet, Sisley, and Pissarro were mainly interested in changing effects of light upon a scene. Renoir experimented with pure, bright colors to separate subjects rather than using the conventional outlining in black (Courthion, 1979).

Post-Impressionism and Expressionism Expressionism brought different approaches to painting. It took a variety of forms depending on a painter’s reactions and attitudes toward his work. Color and form described not only the object itself but also emotions. The inspiration of many of these artists came from primitive sources. Strong contrasting colors were adapted to express real emotions (Gottshall, 1989). Expressionism implied an attitude opposed to refinement and was a way to bring social attitudes to a wider audience with one simple language and content. Among the more prominent artists of this movement were Van Gogh, Cezanne, and Gauguin. Van Gogh and Gauguin used bold masses of color to intensify excitement and emotional reaction to their work (Figure 2). Cezanne emphasized a distortion of the human form which was adapted from his studies of El Greco. He saw in El Greco’s paintings a powerful way to depict images based on distortion. For these artists, it was not only important to record what they saw, but also to express in their paintings how they felt about the subject.

Fauvism From 1904-1908 in France, a group of painters moved one stage further in distortion of forms and use of bold colors than had their predecessors, the Expressionists. They were called “Fauves” and had just three exhibitions during this period, including one at the salon “*D’ Automne*” in 1906. Although it existed only for a short period of time, this movement not only had a great impact in different areas of art, but also in social, economic, and political aspects of life — such as architecture, graphic

design, and typography. Among the painters who belonged to this group were Rouault, Braque, and Matisse (Figure 3).

Fauvism and Cubism came to America for the first time during the famous Armory Show in New York in 1913. At that time, the *New York Times* used headlines such as “*Cubists and Futurists make insanity pay*” (cited in Gottshall, 1989, p. 14). It took twenty to thirty years for American Society to accept these new movements.



Figure 2. Vincent Van Gogh. *The Starry Night*

Art Nouveau Art Nouveau, a movement at the turn of the century (c. 1890-1910), affected all aspects of design arts — architecture, furniture and product design, fashion and graphics. The sources of Art Nouveau include William Blake's book illustrations, Celtic Ornaments, The Rococo Style, The Arts and Crafts Movement, pre-Raphaelite paintings, and Japanese decorative design and wood-block prints (Meggs, 1983). Vine tendrils, flowers, birds, and female forms were the basic motifs of inspiration (Figure 4). Art Nouveau was the transitional style between the historicism of the nineteenth century and modern movements (Lewis, 1967). Art Nouveau, in taking away the historic spirit from design, was the first step toward modern ideas.

Modern architecture, Graphic Design and Industrial Design, Surrealism, and Abstract Art all have their roots in Art Nouveau's theory and concepts (Meggs, 1983). In contrast to earlier styles, its basic form of design was determined by the design of the ornament. In its predecessor styles, decoration was applied to the surface of the building or object. The new design principle unified decoration, structure, and intended function. Rather than copying forms from nature or the past, Art Nouveau often invented shapes and forms. Another important source of inspiration came from the works of Vincent Van Gogh, the flat color and organic contour of Paul Gauguin, and the work of the Nabis Group who explored symbolic color and decorative patterns (Meggs, 1983).

The Belgian Henri Van de Velde, who was one of Art Nouveau's leading practitioners, was invited in 1902 to reorganize The Weimar Arts and Crafts Institute and The Weimar Academy of Fine Arts. In 1919, these academies were transformed by Walter Gropius into The Bauhaus. Van de Velde as well as El Lissitzky from Russia and Theo van Doesburg from Holland were important forces of influences at the Bauhaus, although they

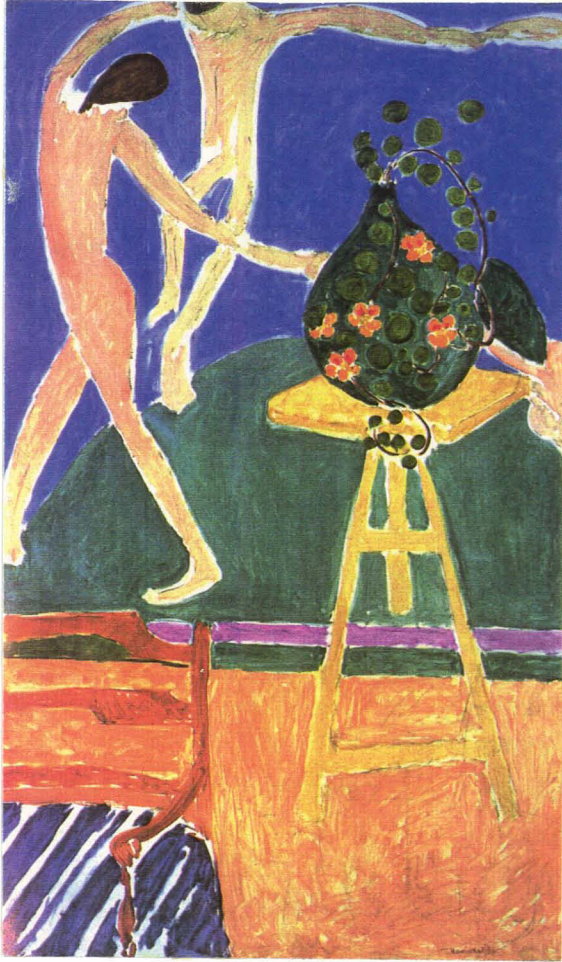

Figure 3. Henry Matisse.
Nasturtiums and the Dance II, 1982



Figure 4. Alphonse Mucha.
Gismonde poster, 1894

never belonged to the faculty. These kind of influences testify the relationship among art disciplines.

Cubism In the early 1900s another movement in painting developed: Cubism depicted objects from different viewpoints by using volumes and planes in different directions. Since it used objects to represent images, it was not totally abstract in a new way. One of its principal originalities was the insulation of parts of the object represented, transforming it into a partial abstraction. Cubism opened opportunities for the later movements by breaking with the four-hundred-year-old renaissance tradition of pictorial art.

Impressionists changed the pure representation by introducing new applications of light and color. Post Impressionists often distorted perspective to emphasize a particular art effect. Art Nouveau artists focused on the decorative aspects of the object itself. In Cubism, technique was focused on overcoming the subject.

The major sources of inspiration of Cubism were the geometric stylizations of African sculpture and Paul Cezanne who considered that “*the painter should treat nature in terms of the cylinder, the sphere, and the cone*” (cited in Gottshall, 1989, p. 17). From this statement came its name. Cubism invented forms by analyzing the subject from different points of view and reconstructing it in a painting by creating visual rhythms.

Cubism was developed by Pablo Picasso, Georges Braque, and Juan Gris among others (Figure 5). Cubism had strong influence on graphic design. Works of E. Mc Knight Kauffer, A. M. Cassandre, Jean Carlu and others can confirm that influence (Figure 6).

Futurism On February 20, 1909 *Le Figaro* of Paris published the manifesto of Futurism by the Italian poet Filippo Marinetti (1876-1944). It established the new ideas of Futurism which were based on a revolutionary concept opposed to museums, libraries,

moralism, and feminism and favoring war, the machine age, and modern life. Marinetti and others developed exciting and vivid poetry without any respect for grammar and syntax; only emotional expression was important (Figure 7).

In 1915, Marinetti called for a typographic revolution against the traditional formats. No more harmony was the goal because it contradicted “*the leaps and bursts of style running through the page*” (cited in Meggs, 1983, p. 276). As a result of a new “*free*

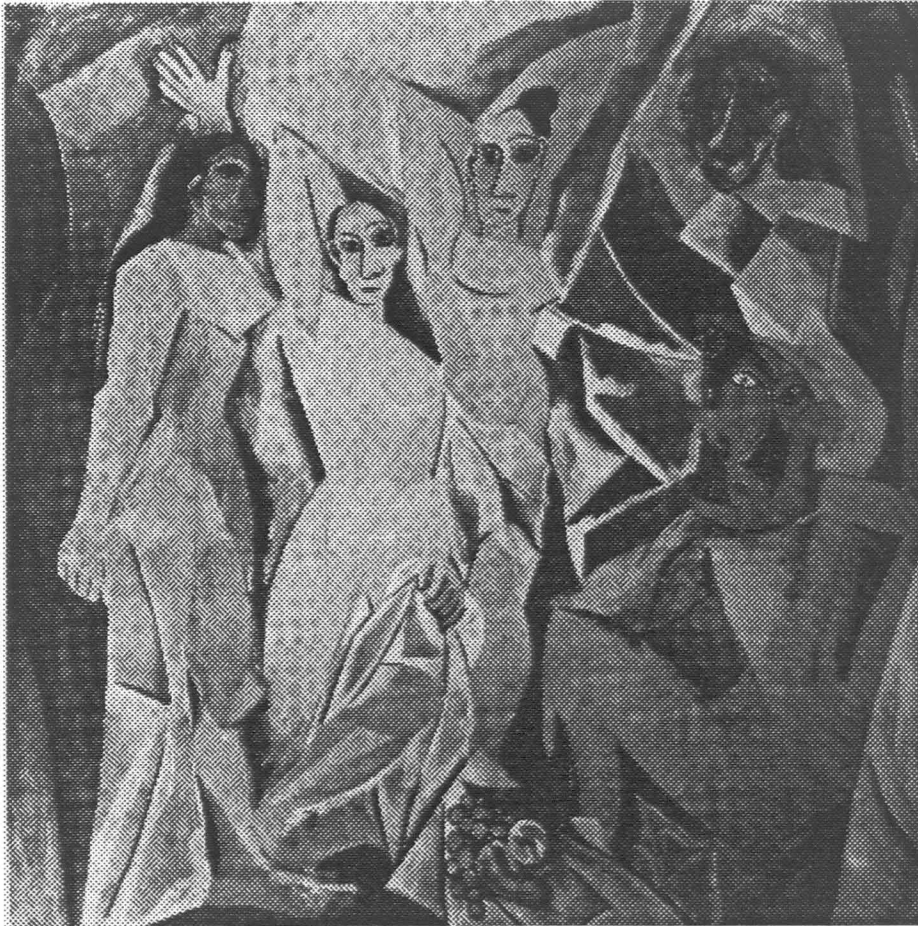

Figure 5. Pablo Picasso. *Les Femmes d'Alger (O. J.)*, 1907

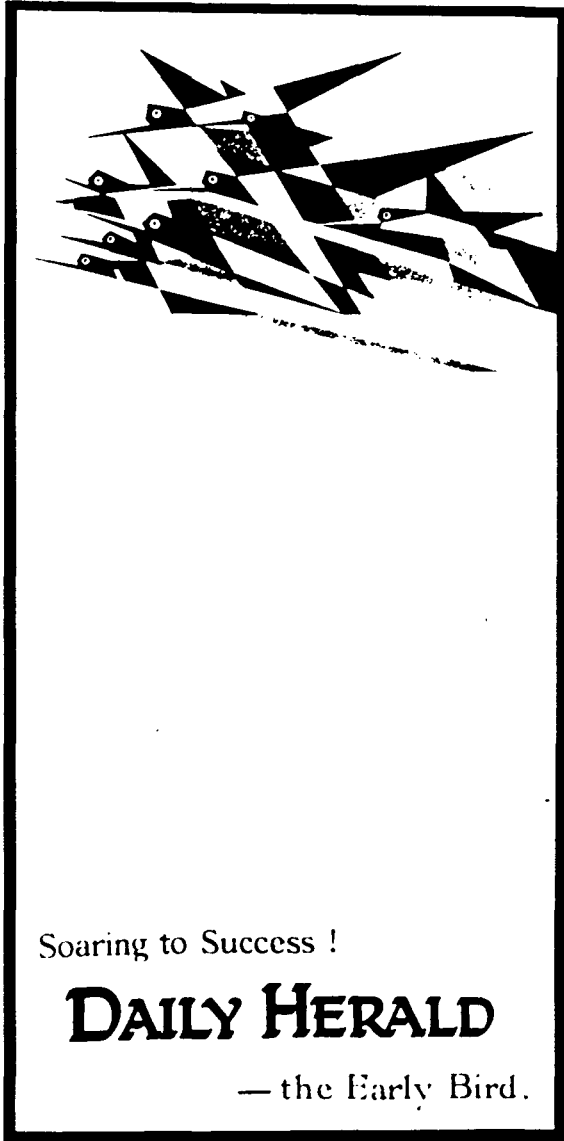

Figure 6. McKnight Kauffer. Daily Herald poster, 1918



Figure 7. F. T. Marinetti. A Futuristic Free-Word composition, 1919

typography” and “*word in freedom*,” Futurists used three or four ink colors and up to twenty faces in one single work in order to emphasize the meaning in printed material. This step broke with the traditional horizontal and vertical structure implanted many years before by Gutenberg with his invention of mobile type.

Futurists implanted their pages with a new vigor. Dynamic and non linear compositions were created by pasting words and letterforms in place of photographic reproduction. Although Futurists were strongly influenced by Cubism, they implanted energy, motion, and cinematic sequence in their work. At the same time, the revolutionary techniques of the Futurists were adopted by Dadaists, Constructivists, and De Stijl.

Fortunato Depero was one of the later Futurists painters, poets, and designers who retained vitality, but with strong emphasis on order. He influenced Italian advertising typography during the 1920s and 1930s. After Depero’s work , typographic design was categorized as: *Passive* (central axis, symmetrical, with minimal contrast), *Active* (asymmetrical, dynamically balanced with clear contrast), and *Aggressive* (unbalanced, blatant with contrasts) (Gottshall, 1989). Futurism opened the doors to a revolution in painting, poetry, and prose.

Dada In July 1917, the periodical Dada edited by Tristan Tzara (1896-1963), a young Hungarian poet, started publication as the main vehicle of the Futureist movement. Tzara and his followers Hugo Ball, Hans Arp, Max Ernst, André Breton, and Richard Huelsenbeck experimented with sound poetry, nonsense poetry, and chance poetry. Dada, as a movement, rejected all tradition and claimed to be anti-art; its goal was a search for a complete freedom of expression. Artists and writers involved in this movement were concerned with shock, protest, and nonsense. Meggs (1983) points out “their rejection of art and tradition enabled the Dadaists to enrich the visual vocabulary of Futurism” (p. 280).

Marcel Duchamp (1887-1968) was the most prominent visual artist of the Dada movement. His famous painting *Nude Descending the Staircase* (Figure 8) was a new abstract representation of motion. The freedom philosophy of Dada allowed Duchamp to create works such as *Ready-Made*, *Found Objects*, *Bicycle Wheel* (Figure 9) among others — everyday objects exhibited as art.

Dada contributed to graphic design development by producing meaningful visual art. Dada artists claim, among other things, to have invented photomontage. Collages and photomontages were created in planned and random juxtapositions contributing to the creative process. Photogram (first called rayogram) developed by Man Ray was another contribution of Dadaists to graphic design.

Kurt Schwitters (1887-1948) created a new branch of Dada that he called Merz. His collage compositions were focused in color against color, form against form, and texture against texture. His works combined nonsense and chance visual elements with strong design properties. In his later works, he was influenced by El Lissitzky and Theo van Doesburg who invited him to Holland to promote Dada.

Surrealism Although Surrealism had its roots in Dada, it claimed to have “poetic faith in man and his spirit” (cited in Meggs, 1983, p. 285). Its base was the world of the unconscious explored by Freud. André Breton was its founder and in his manifesto “Du Surrealisme” he wrote, “Surrealism, noun, masc. pure psychic automatism by which it is intended to express, either verbally or in writing, the true function of thought. Though dictated in the absence of all control exerted by reason, all aesthetic or moral preoccupations,” (cited in Meggs, 1983, p. 285). The followers of Breton were Tristan Tzara, Louis Aragon, and Paul Elvard who defined Surrealism as “a way of thinking and knowing, a way of feeling, and a way of life” (cited in Meggs, 1983, p. 285).

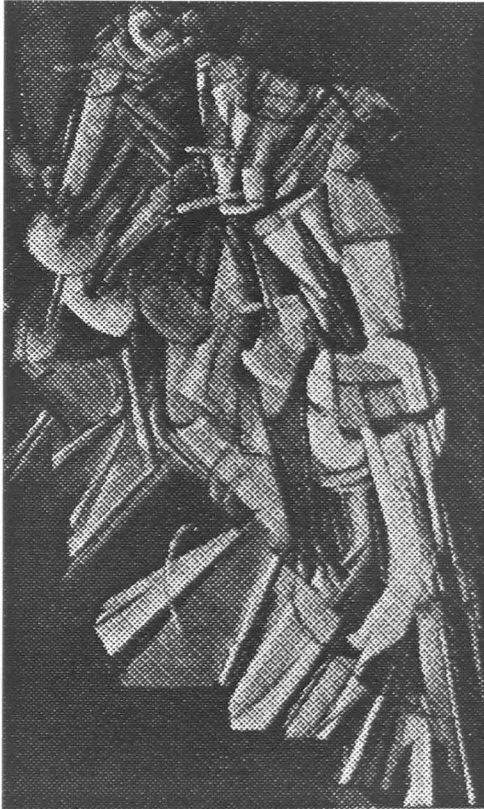

Figure 8. Marcel Duchamp.
Nude Descending a Staircase, 1912



Figure 9. Marcel Duchamp.
Bicycle Wheel, 1913

The major contribution of Surrealism to visual communication has been in photography and illustration. Max Ernst (1891-1965) a German Dadaist who joined Surrealism, developed several techniques that affected graphic communication. He worked with collage techniques to compose directly on the paper — called the “frottage technique” — allowing him to liberate his imagination. Another process was “decallomania” which

allowed him to transfer images from printed pages to drawing or painting, enabling him to incorporate images in unexpected ways. This technique was an important contribution in illustration, painting, and print making.

The Belgian surrealist René Magritte (1898-1967) worked with representations of illusion and reality, truth and fiction at the same time; he created unexpected juxtapositions with scale changes and changes in light and gravity (Figure 10). His images have inspired many visual communicators.

The Spanish painter Salvador Dalí (1904-1989) inspired graphic designers to bring depth and simultaneity to the flat printed page with his deep perspectives and realistic approach to coinstantaneity (Figure 11).

Joan Miró (1893-1983) and Hans Arp (1887-1960) belonged to the group of Surrealist painters who worked with a “purely visual vocabulary” (Meggs, 1983, p.286). Miró, for example, used his subconscious to express spontaneous inner feelings in his paintings, developing organic shapes. These forms and the open composition of these two artists inspired many graphic designers, particularly during the 1950s.

Abstractionist The distinctive differences between a real object and its painted representation became greater and greater during the first decades of this century. In Cubist art, the point of departure of a slight abstraction became a total abstraction that may not be readily apparent in its total abstraction.

This non-objective art could be divided into three kinds: total abstraction of an object, abstraction with no real object as a point of departure, and spontaneous and accidental art (Gottshall, 1989).

Wassily Kandinsky (1866-1944) as well as Klee, Malevich, and Mondrian completely ignored the subject in their later paintings. They wanted their work, like music, to be

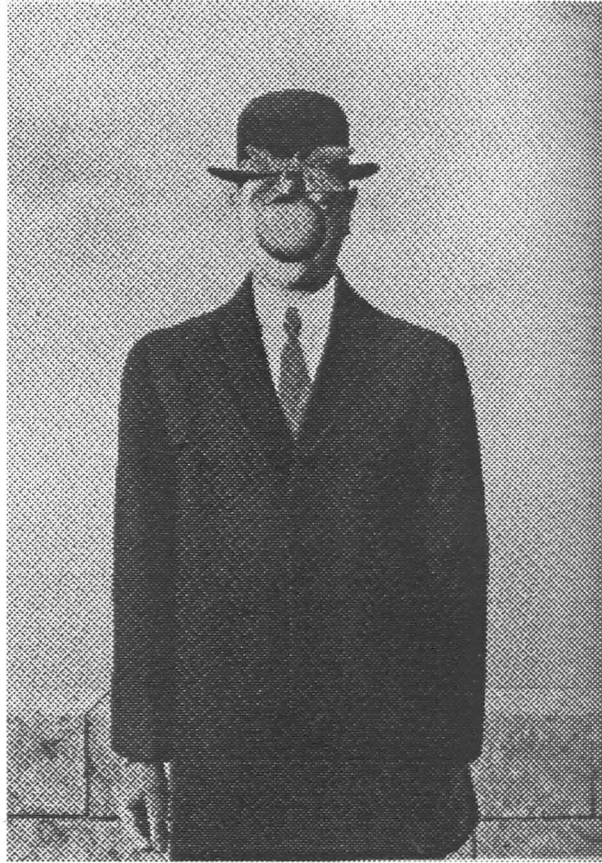

Figure 10. René Magritte.
Son of man, 1964

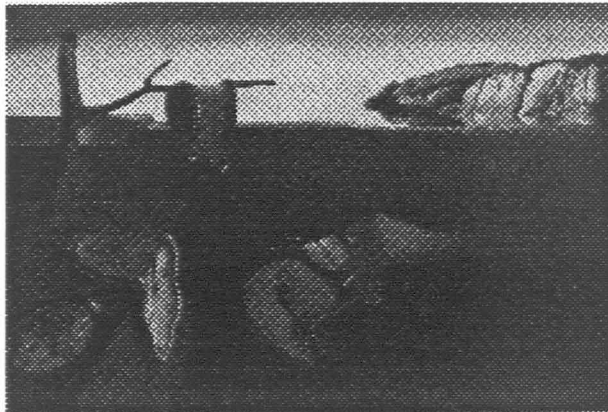

Figure 11. Salvador Dalí
The Persistence of Memory

absolute. Their paintings were not derived from nature. They were departures from color and line — so paintings had a new approach to visual language. Their work had a tremendous impact not only on painting, but also on graphic design, both because of their innovation and the sheer volume of their work.

Kandinsky traveled extensively from his native Russia to Munich, Berlin, Weimar, and Paris. He formed part of the faculty at the Bauhaus in Weimar. He believed that “painting may enter in its musical phase by existing independently of the recognizable object” (cited in Gottshall, 1989, p. 21). Kandinsky described his art as “*Art Concret*” a term suggested by Theo van Doesburg and others in 1930. Major influences on him were Claude Monet, Richard Wagner, the Fauvists, the Suprematists, and the Surrealists.

Kandinsky, Klee, Malevich, and Mondrian among others avoided the natural approach; they wanted their art to be spiritual. Their work was developed from color and line, not from objects or nature. These artists developed a new kind of visual language.

Kasimir Malevich (1878-1935) founded a painting style that he called Suprematism based on basic shapes and pure color (Figure 12). After he had been painting in Cubist and Futurist styles, he developed a new non-objective, pure geometric abstraction; he rejected all pictorial representation. In 1913, he exhibited “*Kvadrat*” (Figure 13), a black square painted in white ground that he described as “no empty square...but rather the experience of non-objectivity” (cited in Gottshall, 1989, p. 25). The movement took its name from Malevich’s idea that art “can achieve the supreme expression of feelings by avoiding practical values and ideas” (cited in Meggs, 1983, p. 312). Art was no longer to represent the subject matter but the essence of the feelings. Among the followers of Suprematism were El Lissitzky and Alexander Rodchenko whose goal was “liberate art from the ballast of the representational world” (cited in Gottschall, 1989, p. 25).

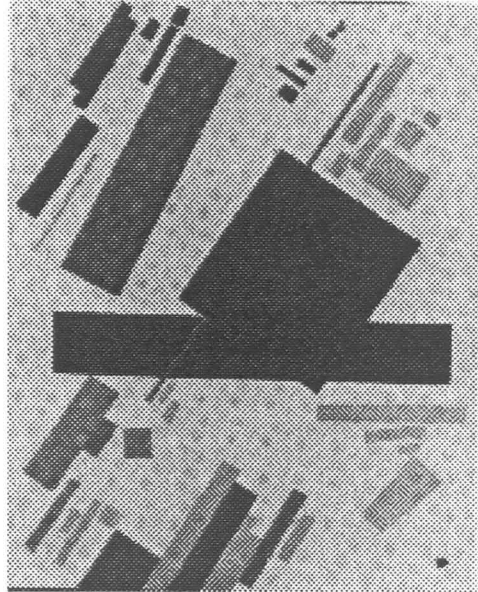

Figure 12. Kasimir Malevich.
Suprematist Composition, 1915

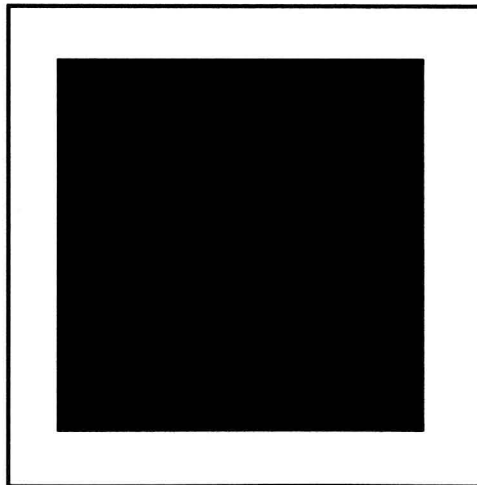

Figure 13. Kasimir Malevich.
Black Square, 1913

Cubism and Futurism had a big influence on Russian avant garde movements when in 1910 and 1914 the Futurist Filippo Marinetti lectured in St Petersburg and in Moscow. The way that Russian artists and typographic designers manipulated graphic elements and white space was changed forever. El Lissitzky and Alexander Rodchenko not only great innovators in painting, but also in typographic design.

Effective communication The Russian Revolution increased the pace of the new movements and turned them to a social role. In 1917, the young artists turned their efforts to a massive propaganda campaign in favor of the Bolsheviks. By 1920, the new role of the artists in the new Communist state was established. However, some artists like Malevich and Kandinsky declared that “art must remain an essentially spiritual activity apart from the utilitarian needs of the society” (cited in Meggs, 1983, p. 312).

Constructivism In 1921, twenty-five artists led by Vladimir Tatlin (1885-1953) and Alexander Rodchenko (1891-1956) renounced “Art for Art’s sake” to dedicate themselves and their efforts to industrial design, visual communication, and applied arts for the new Communist society. Constructivist artists ceased producing “useless things” and turned to the poster as a way of collaborating with the new ideology. Rodchenko, for example, left painting for graphic design and photojournalism, and Tatlin forsook sculpture for industrial design. In 1922, a brochure named “Konstruktivizm” by Aleksei Gan (1893-1942) made an early attempt to describe Constructivist ideology. In this brochure, Gan censured abstract painters and emphasized the practical application of Constructivism. He described the three principals of Constructivism as: Tactonics (the visual unification of Communist ideology), Texture (the use of materials for the industrial production), and Construction (laws of visual organization and creative process) (Meggs, 1983).

El Lissitzky was the major promoter of Constructivism outside of Russia. He moved through different areas of art such as painting, architecture, graphic design, and photography. His visionary attitude profoundly influenced graphic design development. After he studied at the Petrograd Academy of Arts, he turned to architecture at the school of engineering and architecture in Darmstadt, Germany — a change basic to his development of mathematical art. In 1919, he joined the faculty of the Art School in Vitebsky. At that time, Lissitzky developed a painting style called “*Prouns*” (projects for the establishment of a new art). Contrary to Malevich’s picture plane, this style introduced three-dimensional illusions that Lissitzky described as “an interchange station between painting and architecture” (cited in Meggs, 1983, p. 312).

The new conditions of society forced artists toward of a new unity between art and technology by producing objects for the new communist society. This idealism led Lissitzky to turn to graphic design as a way of contributing to the development of the new society. He often used mechanically drawn objects and collage to produce his design (Figure 14). In 1925, he predicted that “Gutenberg’s system belonged to the past, and photomechanical process would replace metal type...” (Meggs, 1983, p. 313). In 1921, he moved to Berlin and had contacts with the De Stijl, the Bauhaus, Dadaists, and other Constructivists.

Through his experiments with photomontage, print making, graphic design, and painting, Lissitsky became the main conduit for Suprematism and Constructivism through Western Europe. Perhaps his greatest influence on graphic design came from his book, “The Isms of Art 1914-1924” edited with the dadaist Hans Arp. Its format was an important step in the organizing of information for visual communication The use of three-

column vertical grid, the three-column horizontal grid for the title page, and the two-column structure of the main text became a guide for organized visual organization. His goal was to encourage reading through clarity and order of presentation. In the service of this goal he used San Serif typefaces and photomontage.



Figure 14. El Lissitzky.
Russian Exhibition in Zurich, poster, 1929

The influence of Lissitzky on Bauhaus typography occurred through meetings in Berlin with Moholy-Nagy, and later through visits to Weimar. Because of his education as an architect, Lissitzky sought visual vitality with order and clarity. Lissitzky combined an analytical mind with a passion for new art forms. As a painter, he experimented with Futurism, Cubism, Malevich's non-objective art, and Kandinsky's abstracts. His sense of organization influenced artists such as Moholy-Nagy, Kurt Schwitters, Herbert Bayer, Theo van Doesburg, and Jan Tschichold (Gottschall, 1989).

De Stijl In 1917, the De Stijl movement and its journal was founded by Theo van Doesburg (1883-1931). He had been working in the Dada style and continued to work on art and poetry during the 1920's. As a De Stijl promoter, he was seeking graphic order in paintings, books, and typographic communications. In 1921, he moved to Germany and, as El Lissitzky had done, established relations with Bauhaus students and masters. Both van Doesburg and Lissitzky played important roles in the development of Bauhaus typography (Figure 15).

Other members of the De Stijl group were Bart van der Leek, Piet Mondrian, Vilmos Huszar. Their philosophy was expanded by the journal as well as by their art; their basic elements were harmony, equilibrium, primary colors, straight lines, and right angles (Figure 16). The totally abstract art evolved by De Stijl artists was inspired by the Cubism of Picasso, Braqué, and Gris.

During the early 1920's De Stijl influenced architecture, industrial design, and typography. Attitudes toward line, space, color, and volume were shaped on these design disciplines. In their manifesto of 1918, De Stijl artists declared that "There is an old and new consciousness of time. The old is connected with the individual, the new is

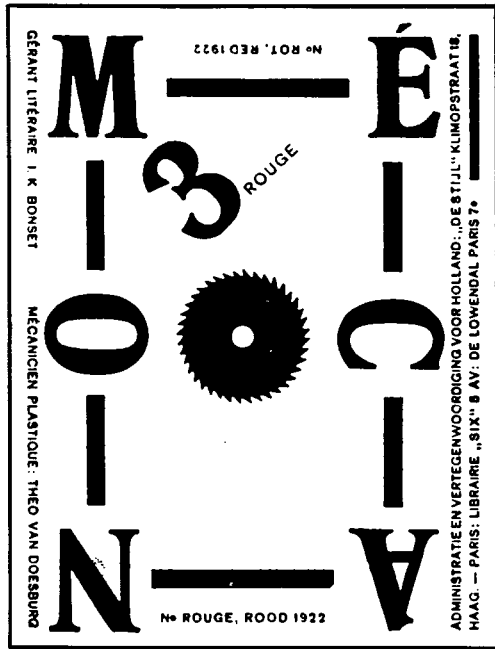

Figure 15. Theo Van Doesburg.
Mecano, no. 3, 1922

ABONNEMENT BINNENLAND 4.50 BUITENLAND 7.50 PER JAARGANG BIJVOORUITBETALING VOOR ANNONCES WENDE MEN ZICH TOT DE ADMINISTRATIE

DE STIJL

ALLE STURKEN DE REDACTIE BETREFFEND 2 BALGEN WATER 2 LEIDEN

MAANBLAD GEWIJD AAN DE MODERNE BEELDENDE VAKKEN EN KULTUUR

ALLE STURKEN VOOR DE ADMINISTRATIE

ADRESSEEREN WENDE MEN ZICH TOT DE REDACTIE: THEO VAN DOESBURG, LEIDEN HOLLAND

27 JAARGANG DECEMBER NEGENTIENHONDERDACHTTIEEN NUMMER 2

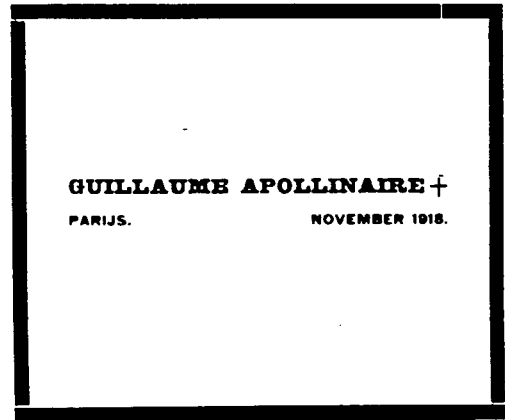

ABONNEMENT BIJVOORUITBETALING BINNENLAND 4.50 BUITENLAND 7.50 PER JAARGANG VOOR ANNONCES WENDE MEN ZICH TOT DEN UITGEVER

DE STIJL

ADRES VAN DE REDACTIE: BONT CALGWATER 2 LEIDEN ADM. 50

MAANDEBLAD VOOR DE BEELDENDE VAKKEN. REDACTIE THEO VAN DOESBURG. UITGAVE X. HARMS TIEPEN. TEL. 720 EN 600

14 JAARGANG APRIL NEGENTIENHONDERDACHTTIEEN NUMMER 8

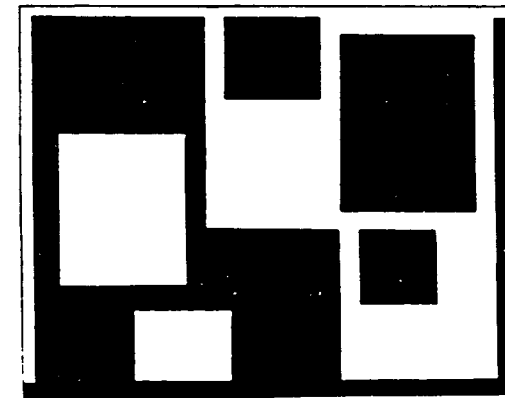

Figure 16. Vilmos Huszar.
Title pages for *De Stijl*, 1918

connected with the universal...” (cited in Jaffé, 1982, p. 12). Since 1917, Van Doesburg, (as later in 1921 did El Lissitzky and Rothenko), believed that art was and existed as social function. He was energetic and extremely talented, he lectured, wrote, taught, organized meetings and his ideas influenced architecture, painting, typographics, sculpture, furniture, and product design.

Although Piet Mondrian did not work with typographic design, his presence in the United States encouraged many typographic designers, artists, and art directors to adopt his ideas. His geometric compositions — demonstrating order, vigor and beauty — had tremendous impact in graphic design and advertising in the United States (Gottschall, 1989).

The Bauhaus The Bauhaus opened its doors in Weimar, Germany in 1919. It was a multi-disciplinary mix of fine and applied arts that emphasized excellence of form and function. It demonstrated a learn-by-doing attitude and a new philosophy of artistic expression. Architecture, painting, sculpture, product and graphic design were the focus. Artists and designers from all over the world came to the Bauhaus to share knowledge and new ideas and then spread Bauhaus ideas through out the rest of the world. Typographic design was changed by the hands of Bauhaus masters like Johannes Itten, Laszlo Moholy-Nagy, Herbert Bayer, Joost Schmidt as well as by the influence of Theo van Doesburg and El Lissitzky.

After Johannes Itten’s resignation in 1923, Laszlo Moholy-Nagy took the preliminary course, which was obligatory before selecting a specific workshop. With his arrival, typography became an important area into the Bauhaus. Moholy-Nagy’s major contribution to the Bauhaus was the designing of the “Bauhaus Books” in which the Bauhaus style started to develop (Figure 17). When Moholy-Nagy lived in Berlin, before his arrival to

Weimar, he had much contact with El Lissitzky and had absorbed constructivist's ideas of vitality and order. He brought many of Lissitzky's ideas to the Bauhaus and invited him to conduct seminars for the Bauhaus students.

In his first work as a painter, Moholy-Nagy was highly influenced by Malevich's work. When he was living in Berlin, in 1921, his studio became a meeting place for people like van Doesburg, El Lissitzky, and Kurt Schwitters. In 1922, he started experimenting with photography after he saw rayograms' Man Ray and developed photograms technique. In 1928, he resigned from the Bauhaus at the same time as did Gropius. Later, in 1937, he founded "The New Bauhaus" in Chicago.

In 1925, the Bauhaus moved from Weimar to Dessau and in this year, five members were added to the teaching staff: Josef Albers, Joost Schmidt, Marcel Breuer, Hinnerk Scheper, and Herbert Bayer. Also in this year, graphic design and printing were added to the curriculum. With the former Bauhaus student Herbert Bayer in charge of those workshops, new order and vitality was brought to Bauhaus typography (Figure 18). He followed Constructivist lines and featured the use of sans serif type, primary colors, typography without capitals, contrast of type size and weight to emphasize, flush left, ragged right typography, color tints emphasizing key words, and photographs printed in uncommon colors (Gottschall, 1989).

In the same year, Bayer designed Universal type (with no capital letters) based on only a few arcs and straight lines. Bayer left the Bauhaus in 1928 and became the art director at *Vogue*. In 1938, he came to the United States and became consultant to John Wanamaker, J. Walter Thompson, and the Container Corporation of America, and consultant on cultural development at Aspen, Colorado. With carefully organized elements to control eye-flow, his work was a forerunner of grid typographic design.

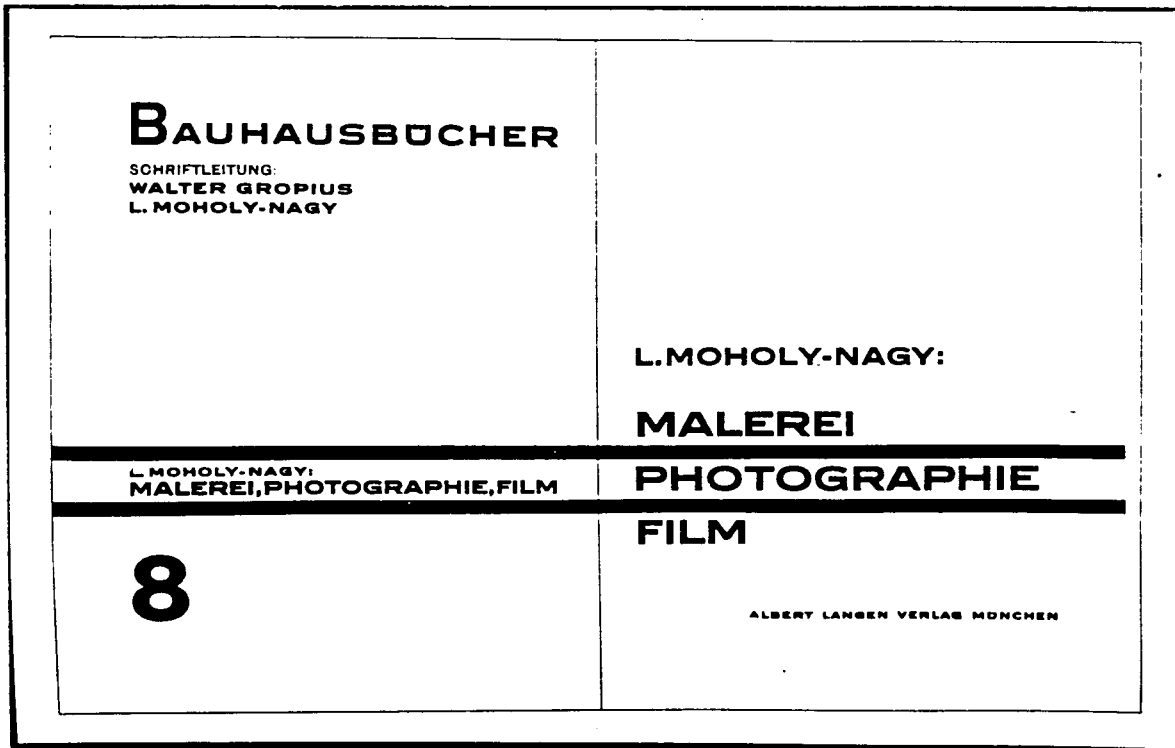

Figure 17. Moholy-Nagy. *Bauhaus Prospectus*, 1923

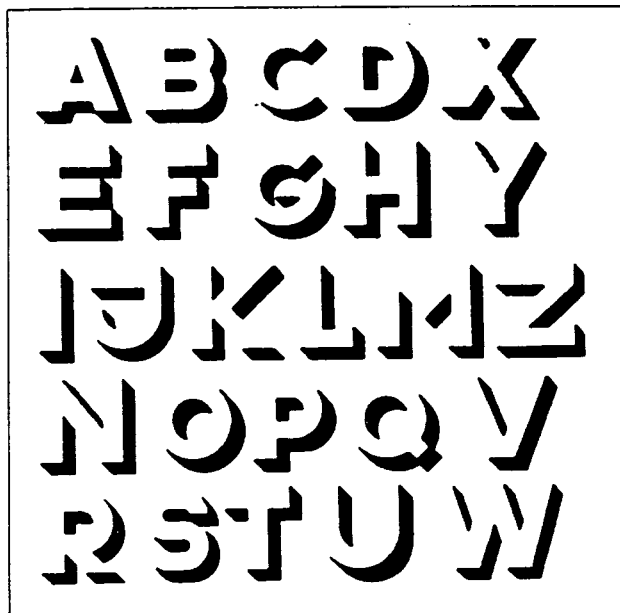

Figure 18. Herbert Bayer.
Experimental Alphabet

The brief Bauhaus chronology is: Weimar 1919-1925; Dessau 1925-1932; Berlin 1932-1933. Dessau was the crucial place for the development of functional and vigorous typography (Wingler, 1986). The year 1933 marked not the death of the Bauhaus, but the birth of an international force which started with Jan Tschichold as an apostle of Bauhaus typography, the functional typography of Swiss designers, and the emigration of Bauhaus figures to the United States. The real importance of Bauhaus typography was the new way of thinking about typography as a powerful communication tool. The blend of clarity with visual vitality was the result of Bauhaus thinking. This philosophy affected every form of printing media (Gottschall, 1989). Typography design today has its base of effectiveness in the work developed in the Bauhaus. Without the Bauhaus, typography would not be the same.

New Typography Jan Tschichold was born in Leipzig, Germany, in 1902. He studied at the Leipzig Academy of Book Design. He heard lectures from traditional designers such as Edward Johnston and Rudolf von Larisch, but he was interested in the avant garde works of Kurt Schwitters, Theo van Doesburg, El Lissitzky, Moholy-Nagy, and Piet Zwart. Although he was neither a student nor a teacher at the Bauhaus, he was its apostle. Through his writings, teachings, and typographic design, he spread Bauhaus ideas of typography through Western Europe, the United States, and Canada.

In 1928, he wrote his major book "*Die Neue Typographie*" (The New Typography) in which he advocated a complete break with traditional typography; this book was extremely influential (Figures 19 and 20). The purpose of the new typography was to make reading easy; he favored sans serif typeface styles because of their simplicity — not their fashion. He once wrote "sans serif is the type of the present day" and also "we aim at simplicity; we therefore require simple and clear typefaces" (cited in Gottschall, 1989, p. 40). Tschichold

VORZUGS-ANGEBOT

Im VERLAG DES BILDUNGSVERBANDES der Deutschen Buchdrucker,
Berlin SW 68 Oranienstr. 6, erscheint demnächst:

JAN TSCHICHOLD
Lehrer an der Meisterschule für Deutschlands Buchdrucker in München

DIE NEUE TYPOGRAPHIE
Handbuch für die gesamte Fachwelt
und die Einzelhandelsbuchhandlungen Berlin

Das Problem der neuen gestaltenden Typographie hat eine lebendige
Diskussion bei allen Beteiligten hervorgerufen. Wir glauben dem Bedürf-
nis die aufmerksamen Fragen ausführlich behandeln zu sollen. Zu ent-
scheiden kann vorerst nur die Handlung der **INDIVIDUELLEN**
Verantwortung.

Es hat dem Verfasser, einem einer bekanntesten Vertreter in diesem
Buche zunächst darauf an, dass unsere Zusammenfassung der neuen
Typographie mit dem **Gesamtsystem** des gesamten Lebens zusammen-
hängt und zu bestimmen, daß die neue Typographie nur ebenso selbstän-
diger Ausdruck einer neuen Gestaltung ist, wie das neue Buchdruck-
werkzeug, das mit unserer Zeit eintritt. Diese geschichtliche Zusammen-
hang der neuen Typographie bringt wiederum eine kritische Dar-
stellung der **alten Typographie**. Die Entwicklung der **alten** Typogra-
phie, die für viele Jahre unserer Zeit gültig beherrschend gewesen ist,
wird in einem noch abzurufenen Aufsatze des Buches leicht faßlich dar-
gestellt. Ein kurzer Abschnitt „Der **Ursprung** der neuen Typogra-
phie“ wird in dem nächsten Teile des Buches, dem **Druckverfahren**
der neuen Typographie über. Diese werden hier herausgehoben,
richtige und bessere Beispiele unserer gegenwärtigen. Zwei weite-
re Artikel behandeln „**Plakatographie und Typographie**“ und
„**Neue Typographie und Bewegung**“.

Der Hauptteil des Buches für den Praktiker besteht in dem zweiten
Teil „**Typographische Hauptformen**“ (siehe den **Arbeitslehre**
Lehrplan). Es folgt hierauf ein **Wörterbuch**, das in diesem Buch
die schon im **alten** Buchdrucke aufgeführten **drucktechnischen**
Fragen in **gelehrter** Ausdrucksweise beantwortet. Jeder **Text**
wird hier **anschaulich** typographisch dargestellt. **Wichtige** von **alten**
Abbildungen über **in** **bestimmter** **Reihenfolge** der **Deutschen**
Typographischen, sind **unter** **8** **personen** **Verstärkung** und
andere **Beispiele**, **Geometrie** und **Skizzen**.

Für jeden Buchdrucker insbesondere jeder **Illustrator**, wird „Die
neue Typographie“ ein **unverzichtbares** **Handbuch** sein. **Von** **nicht**
geringer **Bedeutung** ist es für **Retouchisten**, **Druckgraphiker**,
Lehrkräfte, **Photographen**, **Buchhändler**, **Verleger** und **Büchler**,
aus **der** **Art**, **da** **mit** **dem** **Buchdruck** **in** **Beziehung** **steht**.

Das Buch enthält über **125** **Abbildungen**, von
denen **etwa** **das** **Viertel** **druckfertig** **gebunden** **ist**,
und **umfaßt** **etwa** **200** **Seiten** mit **geringen** **Maß-**
stabangaben. Es **erscheint** **im** **Format** **80x** **110** **mm**
210 **mm** und **ist** **in** **einzelnen** **Heften** **gebunden**.

Preis im **Vorverkauf** bis **1. Juni 1928** **5.00** **RM**
durch den **Buchhandel** nur **zum** **Preis** **von** **6.50** **RM**
Buchhandlung **unmittelbar** **5.00**

Figure 19. Jan Tschichold.
Die Neve Typographie, 1928

JAN TSCHICHOLD

DIE NEUE TYPOGRAPHIE
EIN HANDBUCH FÜR ZEITGEMÄß SCHAFFENDE

DEZ. 1928
VERLAG DES BILDUNGSVERBANDES DER DEUTSCHEN BUCHDRUCKER

Figure 20. Jan Tschichold. *Die Neve Typographie*, 1928

became the voice and the conscience of the new typography through his more than fifty books, some of them translated into five languages.

The Sabon family was his best known typeface design. Contrary to his early ideas, this typeface is a roman design based on *Garamond*. At that time he was in favor of classical typefaces and symmetrical composition. With more conservative work, he showed how classical typography can be exquisitely executed; his designs became symmetrical using roman, Egyptian, and script typefaces.

The Grid System Order and vitality in graphic design was introduced by El Lissitzky, and developed later by van Doesburg, Moholy-Nagy, and Bayer. It was spread through the western world by Jan Tschichold, and had its zenith in Switzerland. The schools of Zurich and Basel emphasized systematic order and clarity in graphic communication through grid systems.

Roots of the grid system include the classical architecture of Japanese Zen-Buddhism and the “Modulor System” developed by the french architect Le Corbusier about 1930, as well as the works of Herbert Bayer, Max Bill, and Richard Paul Lohse. The grid system is invisible to the finished print job. It is a structure formed with horizontal and vertical lines which produce empty modules. The grid lines serve to position and align the typographic and pictorial elements of the job (Figures 21 and 22). Any graphic design problem can be applied to a grid system, but grids are useful mainly in news papers, magazines, books, annual reports, and catalogues, where complex tasks are required (Muller-Brockmann, 1981).

Josef Muller-Brockmann (b. 1914) is the Swiss designer whose books and designs were the major influence in spreading and understanding the grid system. In 1959, three Swiss designers Richard P. Lohse, Hans Neuburg, and Carlo L. Vivarelli along with

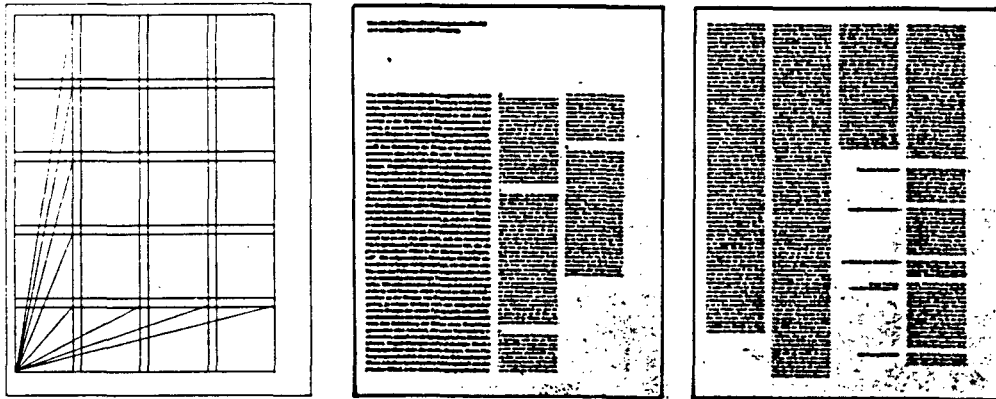

Figure 21. Few possible variations of 20 grid fields applied to text

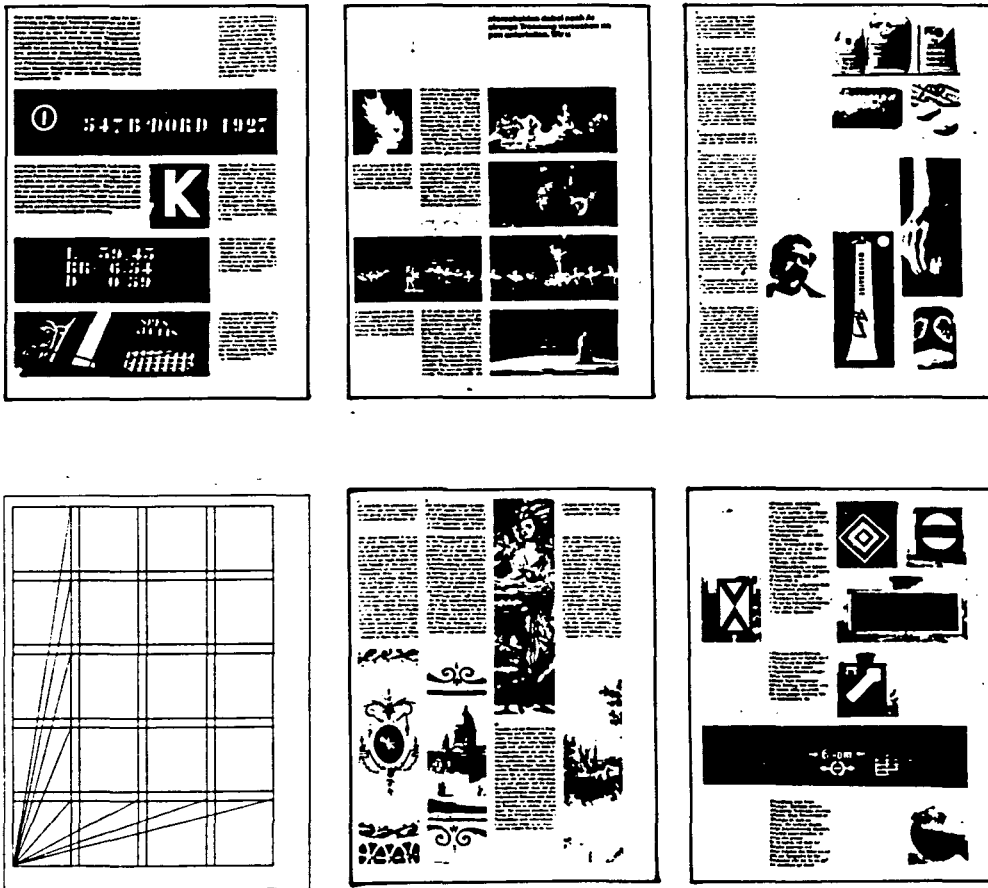

Figure 22. Few possible variations of 20 grid fields applied to text/graphics pages

Muller-Brockmann began the journal *New Graphic Design* — an international forum of Swiss Design (called later International Typographic Design). This journal was a trilingual periodical the format and typography of which were continuing examples of the order and purification reached by Swiss design.

Muller-Brockmann felt that typography should express the spiritual and cultural atmosphere of the time just as painting, architecture, sculpture, music, and literature do. Sans serif was the right kind of letter of his time (1960), because of its functionalism and simplicity (free of ornament). In addition, Muller-Brockmann had been a leading practitioner and spokesman for Objective design. His application of Objective design has been used in a wide range of graphic problems including book jackets, posters, advertisements, packages, stage settings, and exhibitions (Figure 23). He sought universal graphic expression through an objective and impersonal display without the designer's intervening subjective feelings. The visual power and impact of his works of the 1950's can give a measure of his success — today they still look fresh and contemporary.

Subjective Design The emigration of many leading European designers, as well as the publication of Tschichold's writings *Neue Graphik*, and the journal *TM* (later renamed *AD*) introduced American designers to the best contemporary design of the 1930s and 1940s (Gottschall, 1989). Some of the important designers who crossed the ocean were: Mehemed Fehmy Agha, Josef Albers, Herbert Bayer, Lucian Bernhard, Joseph Binder, Marcel Breuer, Alexy Brodovich, Will Burtin, Jean Carlu, A.M. Cassandre, Walter Gropius, Herbert Matter, Laszlo Moholy-Nagy, Piet Mondrian, Massimo Vignelli and many more. They worked in many ways to change the face of American design.

Another important factor in the development of the international status that typographic design in the United States was to achieve was a number of American-born designers

whose vigor and strong personality brought new emphasis to graphic communication. Key practitioners at that time and the early 1950s were: Paul Rand, Bradbury Thompson, Lester Beall, Matthew Leibowitz, Herb Lubalin, Saul Bass, Gene Federico, William Golden, Louis Dorfsman, Jerome Snyder, Milton Glaser, and Rudolf De Harak.

American born designers such as Beall, Golden, Rand, and Thompson not only were influenced by 20th century European art movements and European designers, but also by

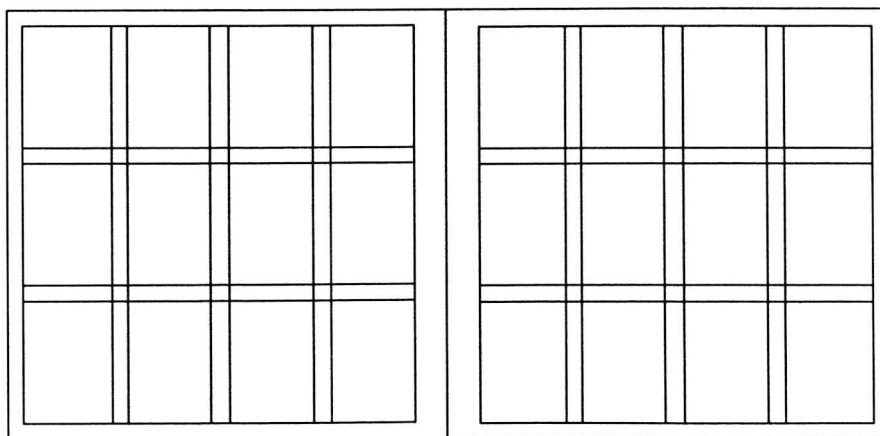
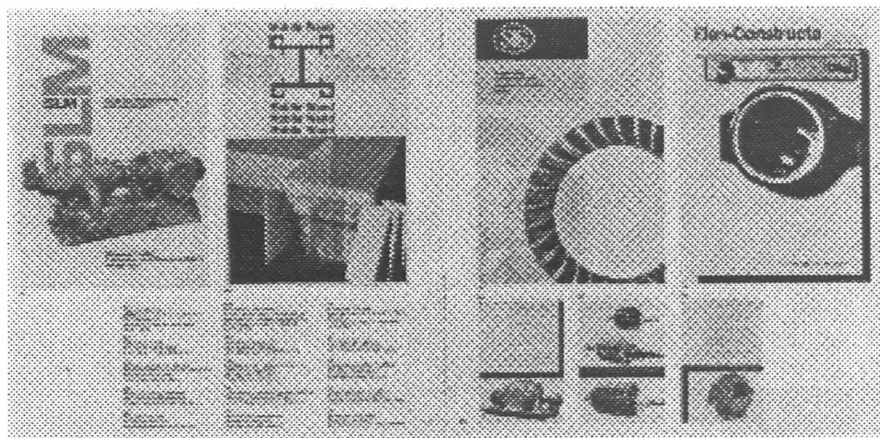

Figure 23. Grid for double page

the American contemporary culture and artists like Thomas Hart Benton, Reginald Marsh, Edward Hopper, Alfred Stieglitz, and Georgia O'Keffe among others. They blend the best of European and American art developments to make graphic design more vigorous and clear, beautiful and functional.

Paul Rand (b. 1914) changed the art director's role from art buyer and layout artist to that of a graphic designer who conceives and executes the message and graphic concepts. He understood that an art director must first communicate, then make art. His design was influenced by George Grosz (his teacher at the Art Students League), *Gebrauchsgraphik* magazine, Jean Tschichold, Le Corbusier, Moholy-Nagy, and A.M. Cassandre. Herb Lubalin once wrote, in *Print* magazine: "Paul Rand's influence on so many of us was really the beginning of the "new school" of graphic design. Paul was the first to break the mold so adamantly adhered to by typographic traditionalists. He showed me and others there was a different way to create graphic images..."

Bradbury Thompson (b. 1911) became one of the most influential graphic designers in post-war America. After work for several years in printing firms in Topeka, Kansas, he moved in 1934 to New York. His knowledge of printing and typesetting, combined with a spirit of experimentation let him put designs for Westvaco Inspirations (from 1939 to 1961) before the eyes of the design community. He explored the potential of eighteenth and nineteenth-century engravings as design resources. Thompson mastered complex organization, form, and visual flow (Figures 24 and 25). In his later works (1960s and 1970s), he turned to a classical approach for periodicals such as *Smithsonian* and *Art News*, postage stamps, and a steady flow of books.

William Golden (1911-1959) joined CBS in 1939 and the next year was named art director. His devotion to the job let him stay one step beyond the conventional role of an art

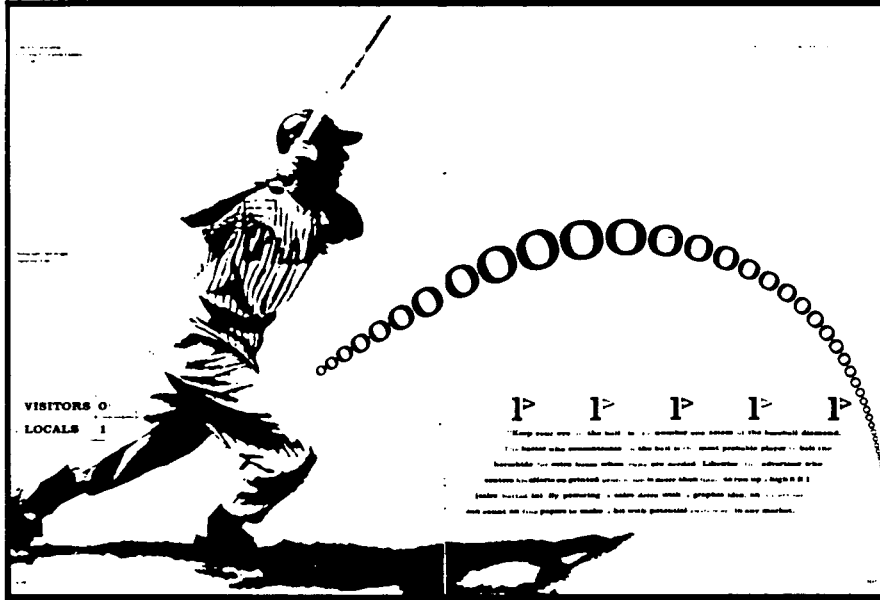

Figure 24. Bradbury Thompson
Westvaco Inspirations No. 210, 1958

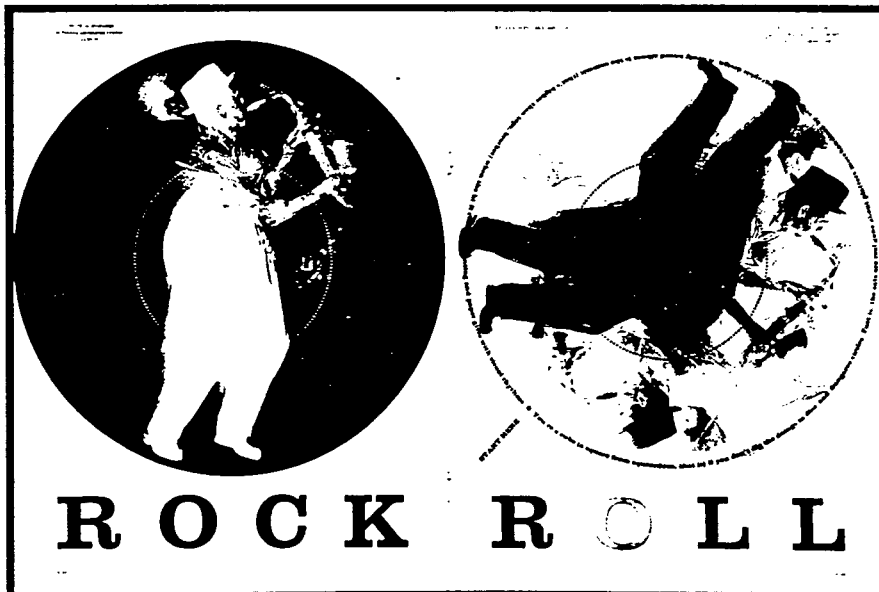

Figure 25. Bradbury Thompson.
Westvaco Inspirations No. 210, 1958

director. He was involved in a project from the beginning. He understood it, analyzed it, and contributed to the development of the communication concept as well as the graphic concept. He believed that a solution to a problem should emerge from the problem and should be appropriate to it. He designed in 1951 the famous “CBS eye” which continues to be one of the most enduring and effective corporate symbols.

Visual language: pictographs, photos, symbols, signs

Many attempts have been made trying to develop a system that easily could be read in all languages without having to be translated. One of the first persons to visualize this was the German philosopher and mathematician baron Gottfried Wilhelm von Leibnitz three hundred years ago (Nigel, 1985). Since then, many efforts have produced artificial languages — such as Esperanto, developed in 1887. This language is supposed to be learned easily by people with a European language background. Another attempt was made by the Australian Charles Bliss in 1949. He developed “Semantography” which is an attempt to create a pictorial alphabet (Figure 26). The system has hundreds of images that need to be learned. One of the most international developments systems was the Isotype Movement.— an attempt not to substitute a complete visual equivalent of language, but rather to produce symbols that could be understood by everyone (Nigel, 1985).

Isotype Movement

The primary idea of the Isotype movement (which began in the 1920s) was to develop a “world language without words,” (Meggs 1983, p. 351). Its concept derives from elementary pictographs that convey information. The Vienna sociologist Otto Neurath (1882-1945) was its founder. Inspired by Egyptian wall frescoes in the Vienna Museum

and diagrams and illustrations in his father's books, Neurath developed a system of elementary pictographs to present complex information. Particular statistical data was developed without decorative qualities. In late the 1920s, Futura was adapted as the official Isotype typeface.

"Vienna Method" changed its name to Isotype (International System of Typographic Picture Education) when Neurath moved to Holland in 1934. A visual contribution to the Isotype movement was the Transformation Team headed by scientist and mathematician Marie Reidemeister (1898-1959). Much statistical research was converted into layout form by the Transformation Team. Most of the pictographs were designed by Gerd Arntz who joined the group in 1928.

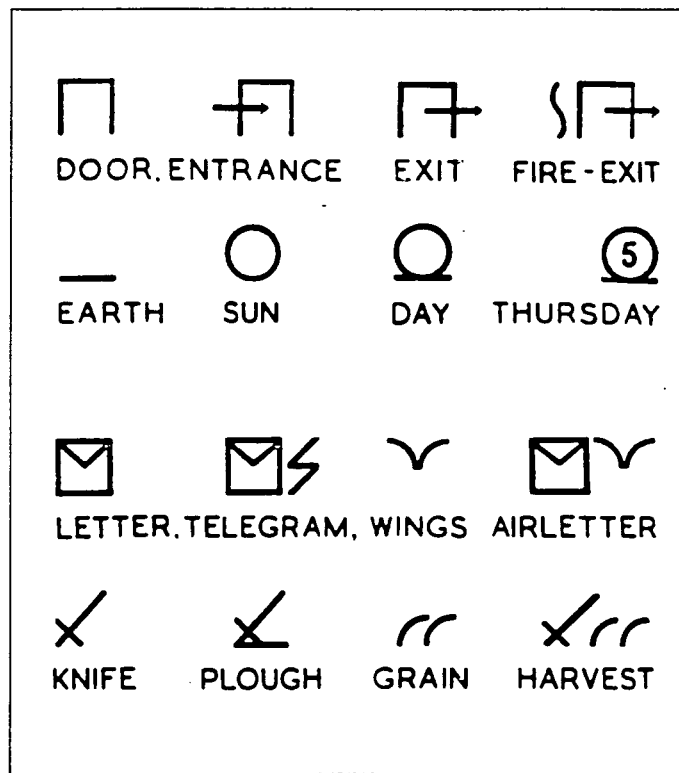

Figure 26. Charles Bliss. *Semantography*, 1949

In 1940, the Isotype group moved to England. One of Neurath's assistants was Rudolph Modley, who in the 1930's had established Pictorial Statistics, Inc. in the United States which now became the Pictographic Corporation, a branch of the Isotype Movement. One of the major contributions of the Isotype Movement was to formalize the use of pictorial language, which includes a pictorial syntax (a system of connecting images to create an order structure and meaning) and the design of simplified pictographs.

Signs and graphic language

Man had moved through history from using prehistoric symbols to using sophisticated verbal communication. Now man had come back to symbols as a way of better communication among nations, languages, and ideologies. A simple shape and/or color is assimilated to the brain faster than a written word (Dreyfuss, 1972). Those seconds of time saved by the reader could be so important they could save a man's life. For example, safety symbols on machine equipment are vital for its operators. Another symbol application is their use on small control buttons for equipment where written instructions would be impossible to read. Symbols can cut across such language barriers. For example, the design of instrument identification and instructions for equipment exported from one country to another with a different language would be expensive and ineffective if symbols are not used.

Symbols can be *representational, abstract, and arbitrary*. Representational symbols describe pictures of objects or action in a simple geometrical way; abstract symbols reduce essential elements of a message to graphic terms (they could originate in a representational way but have become simplified over many years, e.g. the signs of the zodiac); arbitrary

symbols are created, so they must be learned — as, for example, the mathematical plus and minus signs, or the letters of the alphabet (Dreyfuss, 1972).

Symbols have already achieved international acceptance in areas such as music, mathematics, and science. A symphony is interpreted in exactly the same way in Japanese as in German. A Russian scientist easily deciphers equations described in English. Henry Dreyfuss describes a symbol as “A written character or mark used to represent something; a letter, figure, or sign conventionally standing for some object, process, etc.” (1972, p. 18). Today signs and symbols are used in many graphic applications in order to make international communications more effective. Early attempts formed the basis of today’s symbology, as in the case of Ladislav Sutnar and Herbert Bayer.

Ladislav Sutnar came to the United States as design director for the Czechoslovakian pavilion at the New York World’s Fair in 1939 and remained in New York because of World War II. He believed that the “visual unit” is not on the single page but in the double-page spread; he rejected traditional margins because they hinder visual flow. He rejected symmetrical composition because of its lack of functionalism. Instead, he used techniques such as the visual articulation of type, underlining, size and weight contrasts, spacing, color and reversing to improve searching, scanning, and reading.

A simplified graphic language formed with graphic charts, diagrams, and pictures was used to clarify complex information and save the reader time. Unity was achieved by a systematic use of signs, shapes, and color. Sutnar considered the upper right-hand corner of a page as the visual entry point, so it was used for identifying information. He described informational design as “A synthesis of function, flow, and form” (cited in Meggs, 1983, p. 374). For Sutnar, function had a definite purpose: “to make information easy to find, read, comprehend, and recall” (cited in Meggs, 1983, p. 374). He designed industrial

product information for “Sweet’s Catalogue Service” a company that since 1906 had provided a compendium of architectural and industrial product information. Its designs became more functional, the writing style became compact and factual.

In 1953, after five years of concentrated work by Herbert Bayer the Container Corporation published his *World Geo-Graphic Atlas*. This 368-page project contained 120 full-page maps and 1,200 diagrams, graphs, charts, symbols, and other graphic communications about planet Earth. Bayer developed symbols, charts, and diagrams in scientific disciplines such as geography, astronomy, climatology, economics, and sociology. Bayer developed a visual language through this book in order to make man and his world more understandable. Bayer once wrote that “symbols facilitate visual comprehension and suggest comparisons much more effectively than detailed tables which are difficult to remember,”(Bayer 1967, p. 97).

Technical Communication

The word *software* is used to describe methodically and systematically coded instructions such as programs, routines, and symbolic languages, essential to the operation of computers (Andrews, 1975). It also refers to the manuals, circuit diagrams, and flow charts of the computers’ operation and maintenance. Then, “Technical Software” is the language, symbols, ideas, drawings, and manuals, used in technology (Andrews, 1975). Technology depends on technical software, telephone calls, meetings, proposals, reports, and specifications to read and write. Technical hardware and technologists require *technical software* ; without it hardware probably could not exist.

Types of language

Informal language is the language we use with our families and friends. It is the everyday language that is comfortable and easy to use. *Standard language* is more formal and precise than the informal. In a writing manner, it gives the effect of an efficient, business-like way of doing things. It is the standard for letters in industry, government, business, and many other technical patterns. For example, engineering drawings use *standard English*, — numbers and symbols combined from other kinds of “languages”.

Numbers and symbols are read the same way as words in order to communicate meaning. No words are needed to express information. All languages, such as *engineering drawings, symbols, computer languages, and standard English* must be learned. When we learn a specific language, it becomes as familiar and easy to use as our informal language. Just as engineering drawings have specific meaning, the language used must be specific; it must say exactly what the writer means.

Technical software in industry, business, and government uses a variety of patterns. A *technical software pattern* is the words, pictures, symbols, figures, and ideas organized in a given order to convey certain information to a selected audience (Andrews, 1975); good technical patterns produce order and sense. A pattern could be a sentence, a paragraph, or a complete letter (longer technical pattern). *Technical sentences* are built from units (nouns, verbs, modifiers, clauses, phrases) to produce meaning and emphasis; *technical paragraphs* enlarge or expand the meaning of *technical sentences*. A pattern of a letter contains the address of the writer, date of the letter, name and address of the person to whom the letter is being sent, the message, the signature, and other relevant information.

Another technical pattern is engineering drawing (Figure 27). The elements needed to produce it are words, symbols, lines, and numerals. This pattern presents an engineer’s

ideas in an orderly, meaningful way to others. Technical software takes the form of both the *informal pattern* and the *formal pattern*. There are many formal *technical software patterns*. Some of them are: specifications and standards; directions and instructions; letter reports; part lists; reports of tests, investigations and experiments; proposals for action or

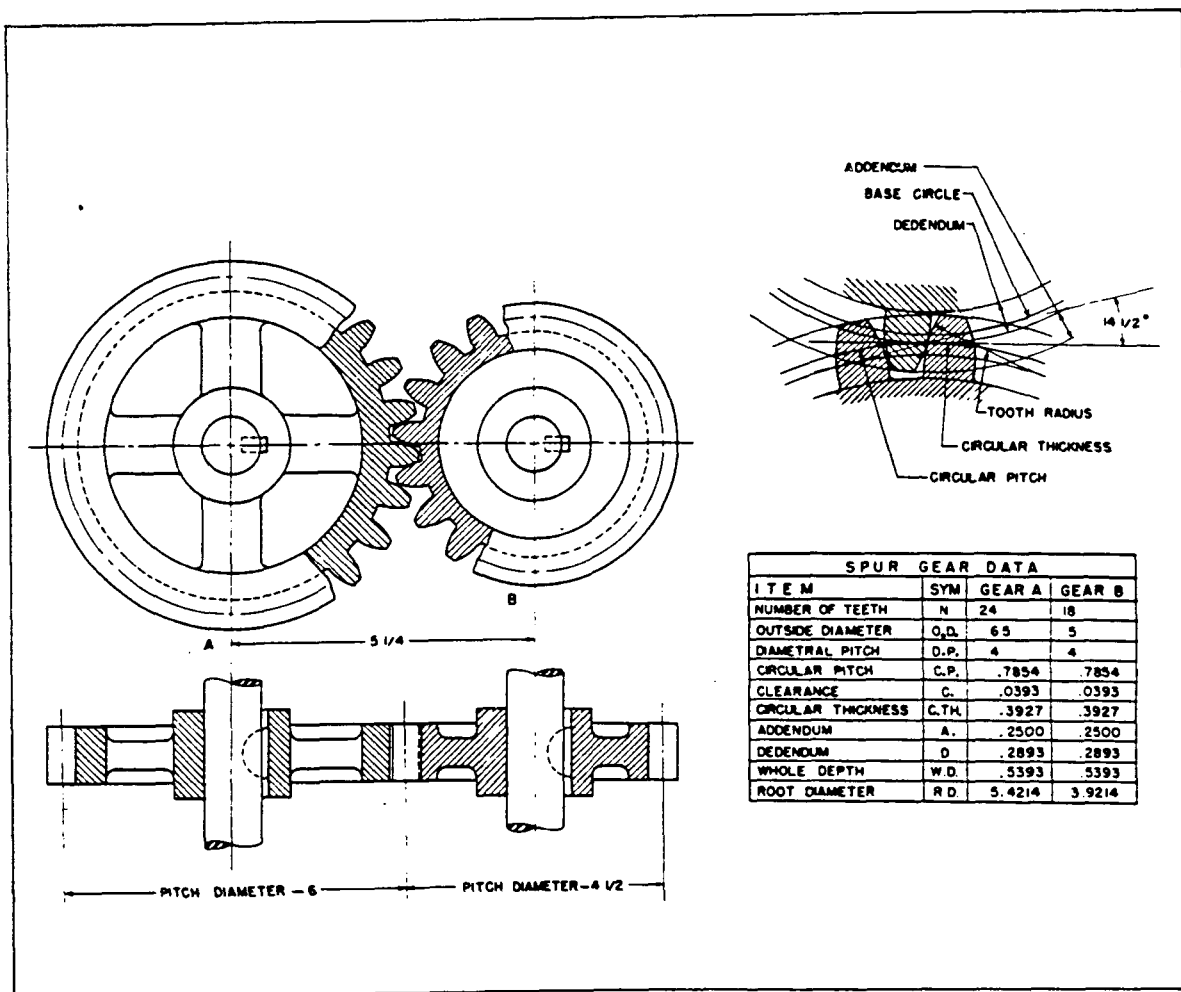

Figure 27. Robert Stebler. Engineering drawing

work; reports of comparisons; job application letters; graphs and tables; minutes of meetings; and oral reports. There are two types of technical software patterns: *language patterns* (sentences and paragraphs) and *structural patterns* (letters, reports, proposals, parts lists, and instruction manuals) (Andrews, 1975).

Description is an information process that allows readers to see and understand specific information. Description provides a “picture” or means of identification and understanding. Types of description include: description in words alone; description through illustrations, photographs, maps, drawings, motion pictures, schematics, tables, graphs, and models; description by means of numeric quantities; description through combinations of some of the above.

Objectivity is the major element in a technical description focusing on the subject. Facts and evidence are points to consider and evaluate. The object described must be shown for the reader’s convenience — not the writer’s. Description is useful for: defining new products, new skills, new tools, new processes; informing people in brochures, catalogues, specifications, and other technical publications; giving basic technical information in writing about operations, experiments, tests, or job skills; writing reports of work done or of decisions made; directing or instructing people in operations, maintenance, assembly, or sales manuals, or where it is necessary for the reader to know about equipment, skills and processes.

“How-to-do-it” information is a special direction or instruction which describes a process. It could be printed on a single sheet of paper or it may be contained in a manual of several thousand pages. It could accompany the product; be sent in a letter, or appear in a specialized magazine or book, or printed on a box or crate. It could be shown on a motion picture screen or video tape.

“How-to-do-it” information can have one or more purposes: it can furnish a parts list; give instructions for assembly or operation; instruct in use or operation; instruct in repairs, adjustments, or maintenance; teach skills, such as selling, explaining, and writing; instruct in unpacking and shipping; give procedures for ordering parts, optional attachments and tools. The written and illustration material in “How-to-do-it” information is basically like other descriptive material. It must be adapted to the purposes of writer and reader.

Writing “How-to-do-it” information is like teaching, but without the presence of students. In the classroom, students can ask questions about topics that they do not understand, but the student-reader cannot do that. So, the information transmitted through this kind of communication must be precise. In “How-to-do-it” information, the “command voice” is required: “do exactly what I tell you” (Andrews, 1975). For example, the phrase “should do that” is in descriptive voice; the phrase “do that” is in command voice.

Technical terms must be defined, especially in a local or special sense. Also, definitions can be created by “pointing to” illustrations such as (see Figure a). Words such as “top, bottom, left, right, below, above” are helpful if the writer makes the reader visualize from his point of view. Words like “clockwise” and “counter-clock-wise” help to specify directions of turns. For example, “rotate the control clockwise 45°.” If the technical name of an item is used in a parts list, the same name must be used in the instructions. The words “should” or “may” must be avoided. The writer must be specific about whether something is to be done or not.

Technical writing

Writing technical instructions has three important points to consider: *instructions shape attitudes*, *visual design*, and *testing* (Anderson, 1987).

Instructions shape attitudes. The writer's most important function is to shape the attitude of the reader toward the instructions themselves — not the most exciting reading for most people.

Visual design. Good page design is the appropriate display of all its graphic components (type, signs, symbols, and images) in order to transmit information effectively and quickly. To do so, a hierarchy among graphic components is indispensable, as Muller-Brockmann (1981) emphasizes: “clear contrasts between the typefaces and sizes make for quick and easy reading” (p. 45). Readers use instructions by alternating between reading and acting — one step read and do the step, next step read and do the step. An effective page design helps readers easily find the instructions for the next step each time they turn their eyes back to the page. If readers are frustrated by a set of instructions, they may quit trying to use them. In addition, good page design helps readers to connect the instructions and the drawing or other visual aid that accompanies it. The appearance of instructions influences readers to use or not use them. Sometimes visual aids are much more economical than words in order to describe where the parts of a machine are located or what the result of the procedure should look like (Anderson, 1987).

Testing. The writer's objective is to tell the reader as clearly and directly as possible what to do step by step. Finding the words that will tell a reader what to do in an understandable, quick, and clear way is not always easy. Because the writer knows the procedure so well, it is easy to leave out some critical information that the readers may

need. The only way to be certain the instructions are understandable is to test a draft with representatives of the intended audience.

In addition to these three general points, a framework for the instruction manual is important. “The *superstructure for instructions manuals* includes an introduction, a description of the equipment, the theory of operation, a list of materials and equipment, directions, and a guide to trouble shooting” (Anderson, 1987, p. 730). The simplest instructions supply only the directions. Other instructions that are more complex could have some or all of the six points enlisted. Many instructions also include elements such as cover, title page, table of contents, appendices, list of reference, glossary, list of symbols, and index (Anderson, 1987). The pattern must be adapted to a particular instruction manual.

Introduction. It could be helpful or even necessary. Point included are: subject, aim, intended readers, scope, organization, usage, motivation, and background (Anderson, 1987).

Description of the equipment. Many instructions describe the operation or repair of equipment. Readers need to know the location and function of parts.

Theory of operation. A description of the way a piece of equipment operates could be helpful for the readers who are interested in do something more than follow a step-by-step procedure. This information is usually located near the beginning of the instructions.

List of materials and equipment. Some instructions describe processes which imply the use of materials or equipment. Inserting a list of such items needed prior to the step-by-step directions will be helpful.

Directions. Presenting the directions in a list helps readers find their place each time they return to the instructions. A distinctive mark at the beginning of each item in the list

(for example, a number or solid circle) is helpful. The use of “command” voice defines the action: “stop the engine” (Andrews, 1975).

Drawings, photographs, and similar illustrations provide important information, such as where things are (by indications), how to perform steps (a hand performing a step), and what should result (showing what should result) (Figures 28 and 29).

Warnings should be placed where readers will see them before performing the steps to which they apply. It should be indicated how to correct a mistake, or how to compensate for one. Sometimes alternative courses of action give readers quick options to find what they want. Enough detail should be provided so that readers can do everything they must do. Therefore, the writer must think about his readers in the act of reading specifically when they will ask “How do I do that ?”

Troubleshooting. People want to know what to do if things don’t work out as they expect. According to Anderson (1987), the most helpful way to provide troubleshooting information is to use a table format (Figure 30). The left-hand column lists the problems that might arise and the right-hand column lists the relevant action to be taken. A middle column could show information about the probable cause of the problem.

In addition to these six points of the superstructure for manual instructions, visual elements aid writing in becoming more informative, easier to use, and more persuasive. Visual elements are not only an integral part of graphic communications, they carry some parts of the message more effectively than does prose. Sometimes visual aids can carry the burden of the entire message. In short, visual aids are powerful communication tools, not mere decorations. To use them well, the designer must think about the readers’ moment-by-moment reactions and create visual aids accordingly.

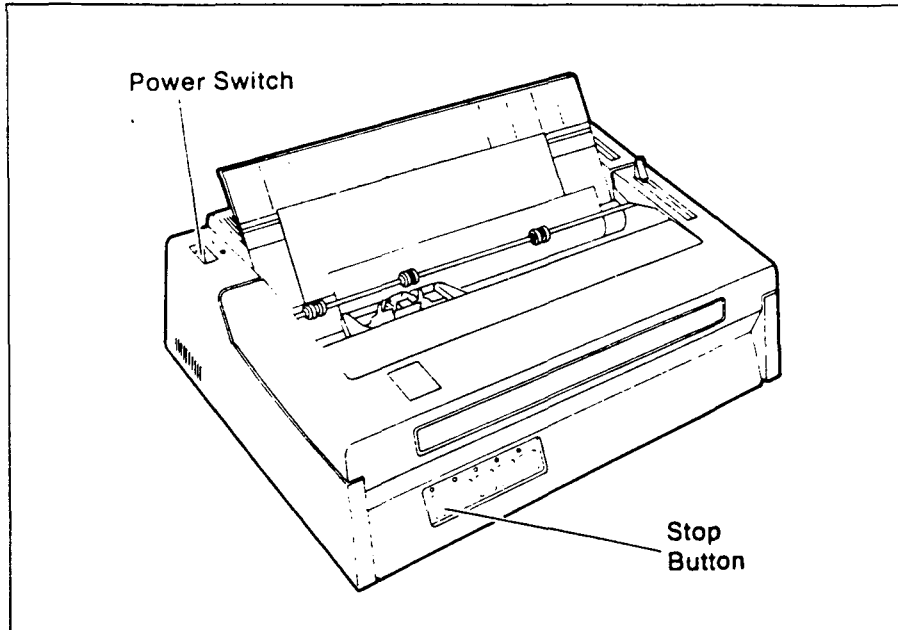

Figure 28. Illustration showing where to locate controls of a machine

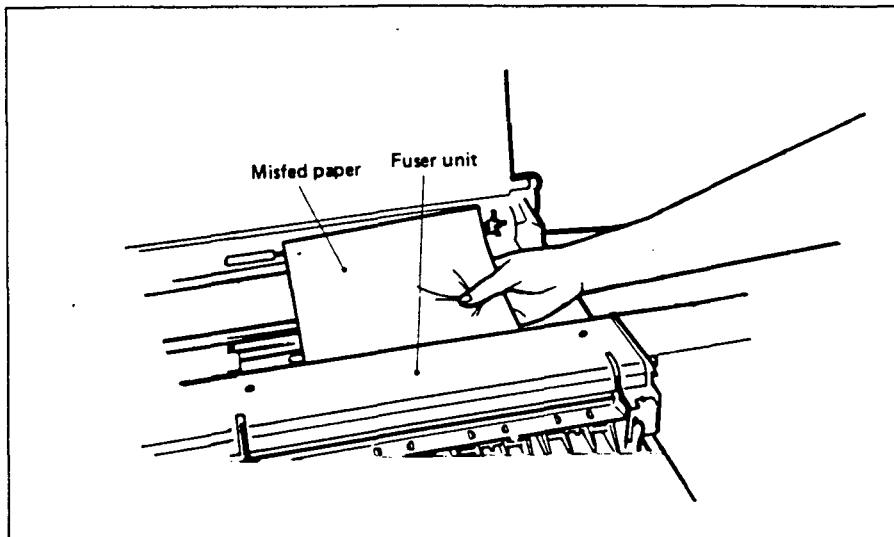

Figure 29. Illustration showing how to perform a step

Chapter 4 — Trouble-shooting

This chapter tells you what to check when trouble-shooting the TOC. It lists the problems that may occur, the probable causes, and the remedies.

The first list in this chapter consists of the error messages that appear on the CRT when a problem occurs. Next to the error messages are the causes of the problem and the possible remedies. A list of all the error messages can be found in Appendix B. The second list consists of observable phenomena that are listed in order of normal TOC operation.

One easily-solved problem is caused by entering entries too quickly to the TOC through the keyboard. If the operator does not wait for the TOC to respond to one request before entering another, errors and inaccurate data will result. Make sure you allow sufficient time for the TOC to respond to your input before you press another key.

Warning

EXTERNAL TEST EQUIPMENT CAN DAMAGE THE TOC. If you use external equipment to trouble-shoot the TOC, make sure that it does not introduce undesired ground circuits or AC leakage currents.

Trouble-shooting with Error Messages

Power-Up Error Messages

<i>Error Message</i>	<i>Probable Cause</i>	<i>Remedy</i>
BACKUP BATTERY IS LOW	1. Battery on Processor Support PCB.	1. Replace the battery on the Processor Support PCB.
CONTROLLER ERROR	1. PC Interface PCB. 2. Processor Support PCB.	1. Swap the PC Interface PCB. 2. Swap the Processor Support PCB.
EPROM CHECKSUM ERROR	1. Configuration tables. 2. Analog Processor PCB.	1. Check the configuration tables. 2. Swap the Analog Processor PCB 88/40.
KEYBOARD MALFUNCTION: PORT	1. Keyboard or keyboard cable. 2. Processor Support PCB.	1. Check the keyboard and cable. 2. Swap the Processor Support PCB.
RAM FAILURE AT 0000:	1. Main Processor 86/30.	1. Swap the 86/30.
RAM FAILURE AT 1000:	1. Main Processor 86/30.	1. Swap the 86/30.
TIGRE PROGRAM CHECKSUM ERROR	1. TIGRE program.	1. Rerun the TIGRE program or debug the program.

Table 4-1. Power-up error messages.

Figure 30. Troubleshooting section

Most information can be conveyed by more than one type of visual aid (Anderson, 1985). To choose the most appropriate, the writer must think about the task he wants his visual aid to enable his readers to perform. Visual aids should be simple and easy to use.

Formats for technical manuals

The way visual elements (type and images) are arranged on a page affects the success of a printed communication. Good page design improves the reader's efficiency, emphasizes the most important subjects, and makes readers feel good about a communication. Well-designed pages establish *visual hierarchies* which tell the readers which elements are more important than others, so readers can read efficiently and easily. Visual hierarchies make use of sizes, positions, and intensities to help control the whole composition.

Page designs are classified according to the number of columns they use (one, two, three, or more), Multi-column grids are used extensively in magazines and periodicals. An advantage multi-column formats is that readers can read shorter lines of type more easily than longer ones. Hollburt (1978) affirms that "the optimum line for ease of reading is 15 picas, and the optimum type face for this measure is 9 point with a character count of about forty-five letters" (p. 31). However, a more general observation is made by Muller-Brockmann (1981) who points out :

The width of the column must be proportioned to the size of the type. Overlong columns are wearying to the eye and also have adverse psychological effect. Overshort columns can also be disturbing because they interrupt the flow of reading and put the reader off by obliging the eye to change lines too rapidly. Lines which are too short or too long reduce the memorability of what is read because too much energy has to be expended. There is a rule which states that a column is easy to read if it is wide enough to accommodate an average of 10 words per line... (p. 31)

Another advantage in the use of multi-column formats is their flexibility for creating interesting designs which emphasize the most important information. They also help the reader see the relationships between different pieces of information, such as when the text is describing a step and the illustration is showing that step in an adjacent column.

Multi-column formats (grid systems) are useful in instructions, technical bulletins, product brochures, and every complex work that needs order and flexibility. Muller-Brockmann (1981) stated that:

...a grid system creates a sense of compact planning, intelligibility and clarity, and suggests orderliness of design. This orderliness lends added credibility to the information and induces confidence.

Information presented with clear and logically set out titles, subtitles, texts, illustrations and captions will not only be read more quickly and easily but the information will also be better understood and retained in the memory. (p. 13)

To create a multi-column grid, the first step is to determine the margins so as to define the communication area (text and other visual materials) of the page. Next, divide this area by means of narrow, vertical gutters of white space (gutters could divide two-column, three-column or more) (Figure 31); these two steps create the basic grid. In order to develop clear, well-organized relationships among text, visual aids, and headings, it is important to align their edges against the appropriate grid lines.

Heading and titles can have a visual relationship to other elements of the page by using the grid pattern. Headings and titles can be placed centered, flush left, or flush right in the appropriate grid columns. A title or heading is flush left when it abuts the left-most grid line of the column or columns it labels; it is flush right if it abuts the right-most grid line of that column or columns (Figure 32).

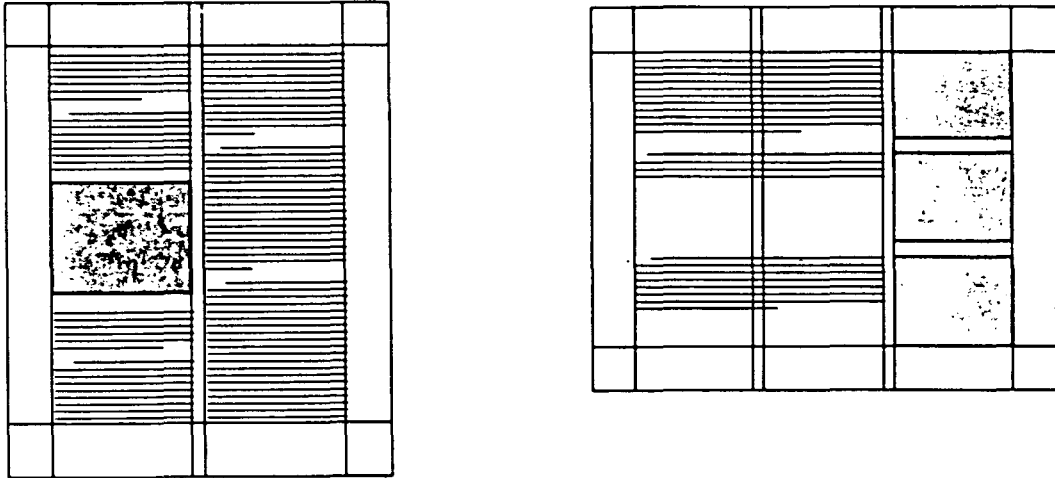

Figure 31. Two alternatives placements of text and visual aids within multi-column formats

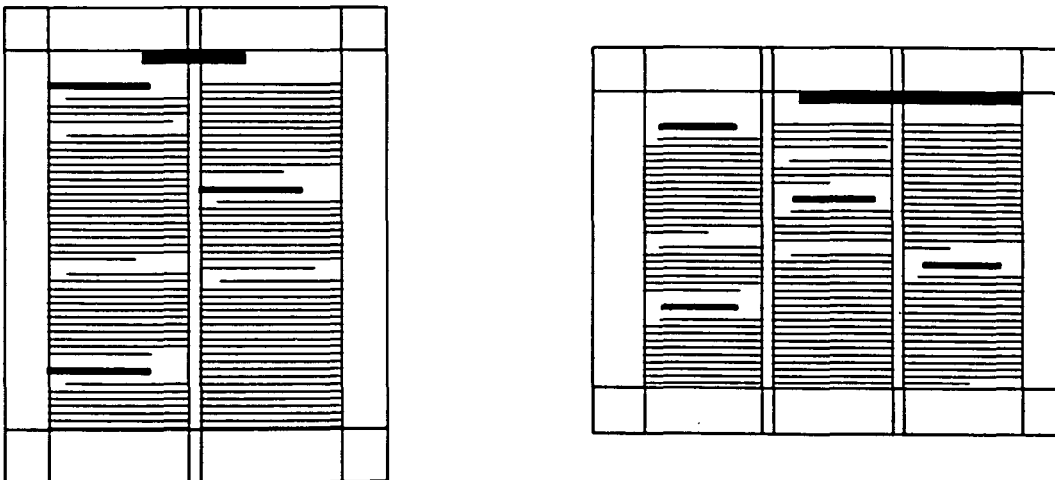

Figure 32. Two alternative placements for heading and titles that span columns

Sometimes major titles or headings may connect more than one column. Even when using larger sizes of type for heading and titles, the basic grid framework holds all the visual elements together. Adding horizontal grid lines to align associated materials in adjacent columns help readers see which text goes with which illustration (Figure 33). In technical manuals, for example, horizontal gutters coordinate each step with its accompanying illustration, helping readers quickly find the step they are looking for. (This applies mainly to communications where each block of text has an associated illustration.)

Another important factor in the legibility of manuals is the consistency of a grid design. Consistency in page design is both aesthetically pleasing and functional. Same grid patterns make pages an attractive group because of the visual harmony among them. Using the same layout throughout allows readers to find the information they want without searching for it. They can simply direct their eyes to the appropriate place on the page. Good instructions and good technical page design enable readers to read efficiently, and encourages them to be more receptive to the information. Some relevant guide-lines are noted by Anderson (1987):

Create a grid to serve as the visual framework for your pages. Begin by establishing your margins, which define the communication area of your page. Draw additional grid lines to define other borders and gutters.
Use the grid to coordinate related visual elements. Coordinate associated elements in adjacent columns by aligning their tops on the same horizontal grid line. Generally, place titles and headings flush left, flush right, or centered between the appropriate grid lines.
The same design for all pages that contain the same type of information.
Consistency in page design is esthetically pleasing and it helps readers find quickly the information they want. (p. 469)

However, there are additional considerations in making printed pages more clear and efficient. Muller-Brockmann (1981) stated:

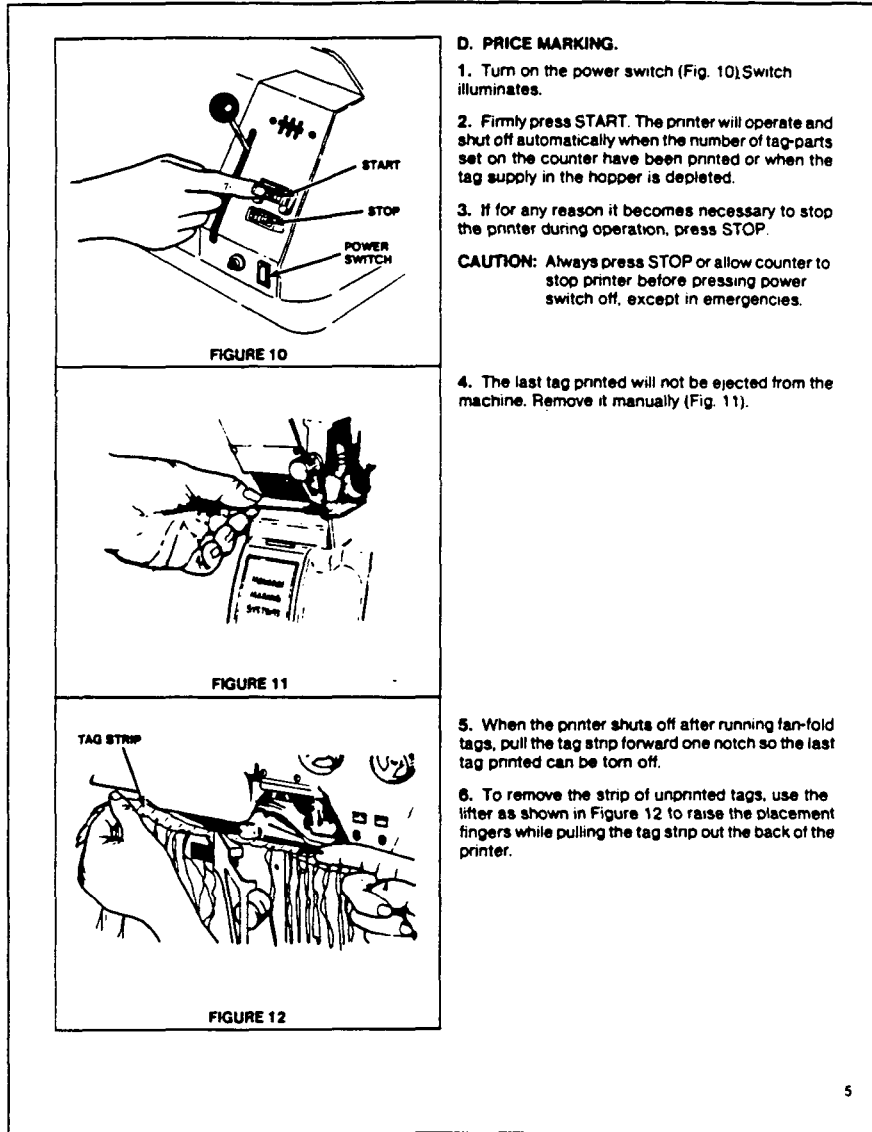

Figure 33. Illustrations with frames and steps

The number of columns — one, two, or more — depends on the printed format and the size of the typeface. Whether the printed page as a whole looks harmonious and is pleasant to read depends on the clarity of the typeface, its size, the length of the lines, the leading of the lines and the size of the margins. (p. 50)

Such considerations have been studied by several researchers through time. Individual letters, type size, line width, and leading . are elements which determine legibility in printed communication. To clarify the many factors contributing to legibility of the printed page, it might be helpful to present some studies related to this topic.

Individual letters: Roethlein (1912) found that the space around each letter as well as the white space within them (such as in o, e, c, etc) determinate legibility and recognition. He found that letters with similar shape (o, e, c, etc.) are often misread. An attempt to make a distinguishing differentiation among individual letters was made by H. E. Meyer for “Linear-Grotesk” (a sans serif typeface) (Figure 34). His design also included a tilt which increases recognition. As Tinker declared: “the variables influencing legibility of individual letters then are the complexity of letter outline, stroke width, heaviness, weight of hairlines, space within and around the letter, and differentiating letter features” (cited in Rehe, 1974, p. 26).

Type size: The most legible type sizes for text are 9, 10, 11, and 12 point (Rehe, 1974). That includes the differences in x-height that exist among the different styles of typefaces. Text sizes larger than 12 point increase the number of fixations because they need more space, both vertically and horizontally. In addition, they force readers to perceive words in sections rather than as a whole, and this reduces the speed of reading. On the other hand, smaller type sizes reduce legibility and hamper of word recognition (Paterson/Tinker, 1943).

In general as Houde (1930) reports, readers like moderate type sizes and small amounts of leading. In referential material though, the space available is the main consideration, as pointed out by Adrian Frutiger (1970). Smaller type sizes than text may be used for such material. However, a general recommendation is made by Rehe (1974): “for text matter, a type size of 9, 10, 11, or 12 point should be selected. For typefaces of a small x-height, 11 or 12 point should be used, while for typefaces of a larger x-height, a 9 or 10 point size might be most appropriate” (p. 29).

Line width: Legibility of running text depends in part on line width which also depends on type size, leading, and type selected. Tinker/Paterson studies determined an optimal line width of between 18 and 24 picas (about 10 to 12 words per line) for text sizes of 9, 10, 11, and 12 point, and 12 picas for text sizes of 7 and 8 point (cited in Rehe, 1974, p. 29).

Leading: Leading is the third major factor of legibility of text matter. Rehe (1974) concludes that:

For optimal type sizes of 9, 10, 11, and 12 point, the most beneficial amount of leading for maximum legibility consists of either 1, 2, 3, or 4 points. Judgment depends on the typeface used. Heavier typefaces need more leading than light ones, but all typefaces are more legible with moderate leading than with out any at all. (p. 31)

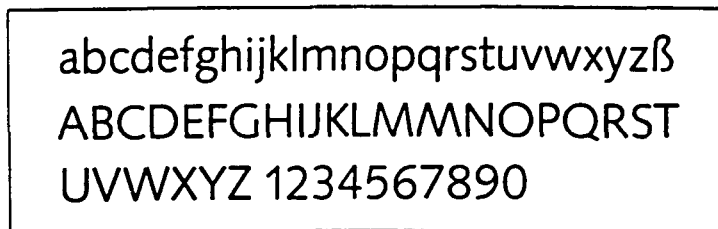

Figure 34. Herbert Meyer. *Linear Grotesk*

Kinds of type: Legibility is also determined by heaviness of individual letters. Since a bold typeface tends to tire the eye easily and a light version reduces legibility (Moss, 1940), a medium weight for a text matter should be selected. On the other hand, italic type compared to roman reduces reading speed by about 14 to 16 words per minute as Tinker (1955) found.

Another factor concerned with legibility in text is the decision regarding whether to use sans serif or serif typeface. One study by Huistendahl and Kahl (1975) found that in serif type compositions, subjects can read between 7 to 10 more words per minute than in sans serif type. Rehe (1974) concludes that “serif typefaces seem to be more legible and are preferred by readers over sans serif type. When they are not contradictory, but supportive to the “tone” of the message, they should be made first choice” (p. 32).

Several studies have proved that no differences of legibility exist between justified or unjustified typography. However, Rehe (1975) points out that:

Application of unjustified typography is recommended on the basis of extensive research findings which did not discover significant differences in legibility between justified and unjustified composition. Unjustified typography reduces production costs, possibly aids legibility, makes for an easier correction procedure, and provides a contemporary, relaxed typographic style. (p. 35)

There are several points to consider regarding the relative legibility of lowercase or uppercase typography. A study made by Tinker/Paterson (1928) they found that all uppercase use up to 30 percent more space than words set in lowercase. Thus does all uppercase type require more time-consuming eye fixations. The study also showed that all uppercase type can be read at 4.74 words per second while all lowercase type can be read at 5.38 words per second. Rehe (1974) stated that “wherever possible, the usage of type set

in all uppercase should be avoided. For emphasis, bold face or a larger type face should use instead” (p. 36).

Summary and Conclusions

The major purpose of this literature review has been the exploration of technical information in the field of graphic design, particularly, in the use of complex information for technical instruction manuals.

The first part of the literature review provided an opportunity to examine the major factors that contributed to the new and dynamic character of graphic design. The art movements of the last part of the 1800s as well as those of the first part of this century gave graphic design the basic structure for its development. Among the most important movements focused on vitality and order were: the Russian avant garde movements (Suprematism and Constructivism), which, in their search for clarity in communication, gave graphic design its base for order; the De Stijl movement, which developed the factors of horizontal and vertical axes as the basis for future grid systems; the Bauhaus, in which the top talents from around the world shared knowledge and defined functional typography, hierarchy in graphic elements, and grid systems; the Swiss school, which in its search for order developed new ways to present complex information in a clear way by use of the grid system; and the New York school, in which the mixing of European and American designers gave graphic design a personal character which emphasized vitality in a more pragmatic way. Although the New York school designers focused on vitality to express their intentions, they were also focused on the content and legibility of the message. Notable designers of this movement were Bradbury Thompson, William Golden, Lester Beall, and Paul Rand, among others. This blend of order and vitality gave graphic

communication not only functionalism through the use of hierarchies, but also visual attraction with the use of contrast.

The literature review also focused on examining types of formats for technical manuals, and legibility in text in terms of its functionality and clarity. The main purpose of the technical manuals is the transmission of “how-to-do-it” information. Describing procedures or steps-to-follow in technical manuals requires a high degree of clarity in graphic communication. Order and vitality give graphic elements (text and image) a structure, allowing them to display functionalism in visually stimulating ways.

Typography as the most conventional way of transmitting information was given special attention in this study. The legibility of a typeface depends on its size, width of its lines, leading of the lines, kind of type used, and the size of the margins. Even the space around each letter and the white space within it impact legibility and recognition. Roethlein (1912) found that letters with similar shapes such as (o, e, c,) are often misread. Some additional factors that influence legibility of each letter are the complexity of letter outline, stroke width, heaviness, and weight of hairlines, among others.

In a normal reading distance, the most legible type sizes for text are 8 to 12 points, including the differences in x-height that the different styles of typefaces have (Rüegg, 1989). Types larger than 12 point increase the number of eye fixations, and types smaller than 8 point reduce readability and word recognition.

Legibility in reading text is also influenced by line width. A rule of thumb says that 10 to 12 words per line in a text size (8 to 12 point) and 8 to 10 words per line in a reference size (5 to 8 point) seem to be the most comfortable for the reader’s eye. This means that the size of the typeface selected will determine the line width. Longer or shorter lines than that described above will subtract efficiency from the action of reading. Short lines prevent the

eye from making maximum use of horizontal perceptual cues; lines too wide contribute to difficulty in relocating each new line.

Another factor in the legibility of text involves the amount of leading. For sizes of 9 to 12 points the optimum amount of leading is from 1 to 4 points, depending on the typeface used.

Legibility is also affected by the kind of typeface used. In continuous text, bold typeface tends to tire the reader's eye and light typeface reduces legibility; medium typeface is often a good option to select. On the other hand, the decision of whether to use sans serif or serif type in text is an important one. As convention dictates, serif typefaces are preferred by text readers. However, this decision also depends on the thematic influences of the message itself, as well as the designer's approach in responding to these influences.

Images as complementary parts on printed pages are vital elements in the development of effective communication in technical material, as well as any other graphic communication. Images can clarify some parts of a communication more effectively than written descriptions, and can sometimes carry the entire message. From time to time attempts have been made to develop systems of images that can be read in all languages without need of translation. One of them was "Semantography", a pictorial alphabet developed by Charles Bliss. Another system that received international recognition was that of the Isotype movement, developed by Otto Neurath. Both systems relied completely on images to carry the total message.

Symbols and signs also are images that can carry messages faster than the written word (Dreyfuss, 1972). In addition to speed and clarity, symbols can cross the language barriers, becoming international tools for (graphic) communication in which entire messages can be transmitted without the use of words.

The knowledge gained in researching this thesis expanded this author's understanding of the effective organization of visual and verbal messages in technical manuals. In addition, the development of the project provided an opportunity to apply this knowledge in an immediate way and evaluate the results.

The project required the selection of a technical manual that could be used as a point of departure. For this purpose an evaluation matrix was implemented — based on the rules of legibility investigated in the literature review.

According to this literature review, “legibility” is directly related to specific factors that should be carefully considered if successful graphic communication is to be accomplished.

The first factor assesses individual letters in the text. They should have: moderately extended type design (condensed type designs are somewhat more difficult to read); medium stroke (fine strokes tend to reduce legibility and their differentiation value); medium heaviness (ideal text type should be medium, neither too heavy nor too light); and medium hairlines (light weight of hairlines tends to reduce legibility.)

Another factor in the matrix deals with text matter. It has been established that: a type size should be 9 to 12 point (the most legible type sizes for text are 9, 10, 11, and 12 point including compensation for differences in x-height); line width should be 18 to 24 picas for 9, 10, 11, and 12 point type (about 10 to 12 words per line); leading for 9, 10, 11, and 12 point should be 1, 2, 3, or 4 points; serif typeface should be used (serif typeface seems to be the most legible and preferred by readers over sans serif type); justified or unjustified typography can be used (studies have shown that no differences of legibility exist between them); lower case should be used for written matter (all uppercase uses up to 30 percent more space than lowercase — increasing time-consuming eye fixations); and visual

highlights (such as black points, bullets, or numbers) should be used for steps to be emphasized in instructional technical manuals.

Headlines (the third factor in the matrix) emphasize that whenever possible sizes of 14 to 30 points should be used. For emphasis, bold face or larger typeface should be used; type set in all-caps should be avoided.

Another factor related to successful graphic communication refers to “image,” a characteristic of visual communication that has to do with appropriateness. Significant elements include: illustrations — should support the text matter; simplicity — a clear and simple illustration helps to understand the subject in instruction manuals; information titles — sometimes the use of titles for illustrations helps to clarify the content of the text; information titles and illustration contrast — titles that run into images should have enough contrast to be readable; illustration hierarchies — images should be placed in a visual hierarchy, depending on their importance of the subject.

Still another factor in the matrix evaluation concerns order. Consistent use of an organizing structure — a grid system to organize graphic elements — should be displayed through the entire manual to help organize graphic components. Repeating typographic format — using the same typographic format throughout the manual helps the reader to find any specific information.

The last factor in the matrix deals with vitality. Asymmetric layout can be a factor for visual reinforcement of type messages which create the sense of vitality. Varied typography, weights, sizes, and styles, and contrast variations are factors that contribute to a sense of vitality. Vitality is a necessary part of a technical manual which is to act as an interface with such a visual technology as a video recorder.

Technical Manuals Review and Evaluation

In order to analyze the elements which are used for communication in this kind of publication, a review of several technical manuals concerned with electronics devices was undertaken. Five manuals for VCRs (each with a different approach to design) were chosen for analysis of their graphic displays in order to select the one with the best design characteristics for use as a base for this project. The manual with the best design characteristics would present the most interesting design challenge. Because each exhibited similarities in use of graphic elements through their compositions, development of an analysis of readability and functionality (applied to technical manuals) was possible.

The manuals used for this purpose were: "Operating Instructions" for the Sony VHS Stereo Video Cassette Recorder SLV-70HF, "Owner's Manual" for the General Electric Video Cassette Recorder 9-7450, "Owner's Manual" for the Symphonic Video Cassette Recorder 7000, "Instruction Manual" for the Sanyo Video Cassette Recorder VHR 3350, and "Owner's Manual" for the Toshiba Video Cassette Recorder M-6100.

In order to make an objective analysis of the factors which determine legibility and visual organization of the five manuals, the same section of each one was chosen. The "Recording Section" of each manual was selected because it contained all the graphic elements needed for such graphic analysis.

Creation of a matrix

To make the selection of the manual to be redesigned more objective, a matrix containing the specific points of legibility and visual organization was developed. The horizontal axis was divided into six main sections which included individual letter forms, text copy, headlines, image, order and vitality (Figure 35). The individual letter forms

section was focused on moderately extended type design, medium strokes, medium heaviness, and medium hairlines — factors which determine legibility according to the literature review. The next section was concerned with the text copy which includes text size, line width, leading, the use of serif typeface, justified and unjustified typography, the use of lower case and visual high-lights to emphasis important points in technical text. The headlines section was focused on the sizes recommended, the use of bold face to emphasis headlines, and font change as a contrast between text and headlines. The image section was focused on selection of appropriate images, its overall simplicity, the use of information titles among illustrations, the contrast necessary between illustrations and information titles, and hierarchies among illustrations which determine their importance.

Another section focused on the structural organization of the whole document and the consistency of typographic format throughout. The vitality section was concerned with asymmetric layouts as a way to stimulate interest in the page design, and variety of typography, weights, sizes, and styles as elements of contrast to reinforce vitality.

The vertical axis was divided in five parts which represented the five manuals in study. Each one was assigned a different letter. Symphonic 7000 = “A”, General Electric 9-7450 = “B”, Sony SLV-70HF = “C”, Toshiba M-6100 = “D”, Sanyo VHR 3350 = “E”. The classification used for this axis was: 5 points for excellent quality, 4 points for good, 3 points for satisfactory, 2 points for poor, and 1 point for unacceptable.

The results of the evaluation of these manuals were as follows: the Sony SLV-70HF manual received 94 points; the Sanyo VHR 3350 manual received 84 points; the Toshiba M-6100 manual earned 80 points; the GE 9-7450 manual received 82 points, and the Symphonic 7000 manual earned a total of 69 points.

LEGIBILITY AND VISUAL RATING					
MANUAL	A B C D E				
SECTION <i>Recording T.V. Programs</i>					
INDIVIDUAL LETTER FORMS					
Moderately extended type design	3	4	4	4	4
Medium strokes	3	4	4	4	4
Medium heaviness	3	4	4	4	4
Medium hairlines	3	3	4	4	4
TEXT COPY					
Size should be 9 to 12 point	5	5	5	5	5
Line width should be 18 to 24 picas	2	5	4	1	2
Leading should be 1,2,3, or 4 point	4	4	5	4	4
Serif typeface	1	4	1	4	1
Justified or unjustified typography	5	5	5	5	5
Lower case should be used	5	4	5	5	5
Visual high-lights	5	3	5	3	5
HEADLINES					
Size should be 14 to 30 point	5	5	5	5	5
Bold face	5	5	5	2	5
Font change (contrast)	2	4	2	2	2
IMAGE					
Appropriateness (Text Support)	2	3	4	3	4
Simplicity	4	4	4	4	4
Use of Information Titles	2	2	3	3	4
Inf. Titles & Illustration Contrast	2	2	4	4	4
Illustration Hierarchies	1	3	5	5	5
ORDER					
Consistent use of an organizing structure	2	3	4	2	2
Repeating typographic format	1	2	4	1	2
VITALITY					
Asymmetric layout	2	2	4	2	2
Varied typography, weights, sizes, styles	2	2	4	4	2
TOTAL: 69 82 94 80 84 - 115 POSSIBLE POINTS					
DESCRIPTION (of the Video Cassette Recorders in study)					
A SYMPHONIC 7000 "Owner's Manual"	C SONY SLV-70HF "Operating Instructions"	E SANYO VHR 3350 "Instruction Manual"			
B GE 9-7450 "Owner's Manual"	D TOSHIBA M-6100 "Owner's Manual"				

CLASSIFICATION

5 Excellent

4 Good

3 Satisfactory

2 Poor

1 Unacceptable

Figure 35. Matrix used for the selection of the manual

Although the Sony SLV-70 HF manual had in this evaluation the highest rating for legibility and use of visual organization, it exhibited some design decisions that could have been better resolved (Figure 36). For example, one of the rules of legibility in text dictates the use of serif typeface. This manual uses sans serif throughout the written material and there is no significant difference between headlines and text, making their relationship ambiguous. In addition, this relationship contributes with a lack of vitality as an important factor in the display design. Although line widths in this manual are close to recommended widths, they are not in the range of 18 to 24 picas for text material. "Difficulties in reading short lines contributes to an inability of the eye to make maximum use of horizontal perceptual cues" (Rehe, 1974, p.29).

Consistency in the design display is another factor that contributes to legibility. This manual has various arrangements among subheads, confusing the description of written material. Some subheads are placed in black rectangles with white typography and others are placed in grey rectangles with black typography.

Another legibility principle insists that bold face type should be avoided in continuous text material because it tends to tire the eyes of the reader. This manual uses large amounts of bold face in text matter, making reading difficult. "The perceived blackness of type against the brightness of the paper background, constitutes an important determinant of legibility" (Rehe, 1974, p. 31).

On the other hand, the manual for the Sanyo VHR 3350 rated second in following the rules of legibility, according to this evaluation (Figure 37). Design observations discover some weaknesses in legibility and in consistency of the organizing structure. This manual did not follow a clear grid system through its display sections. In some parts it made use of two columns, and in others it used only a single column for the text. As a result,

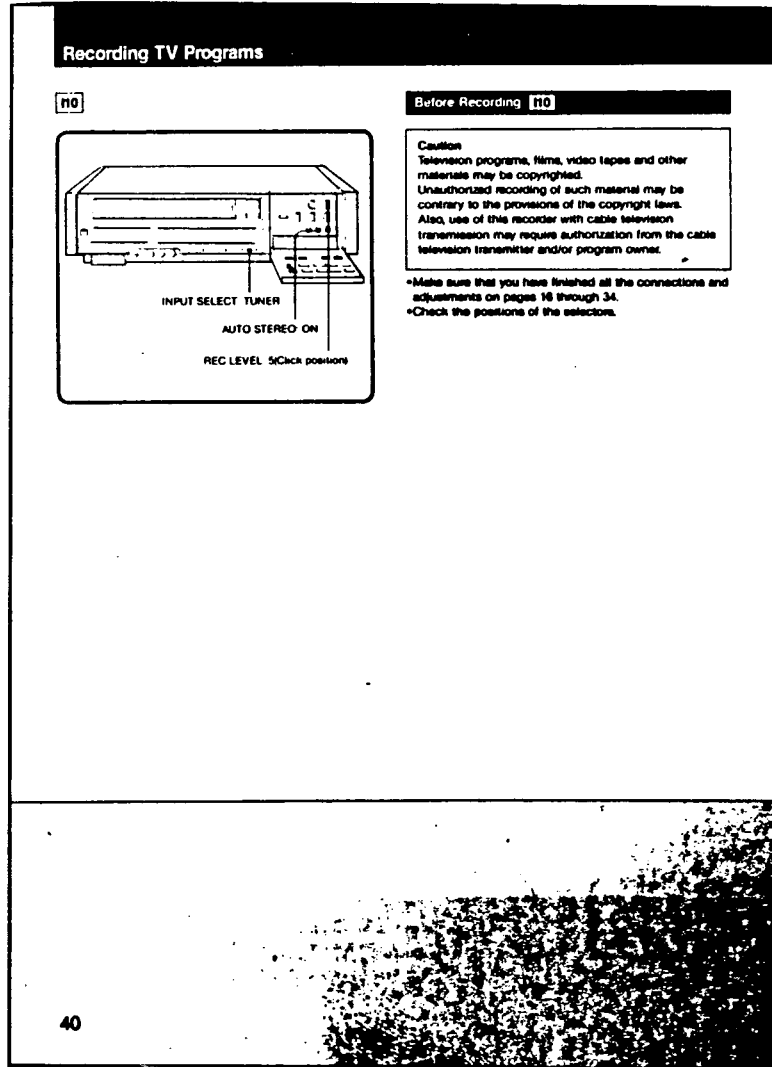

Figure 36. Recording TV programs section from the Sony manual.
 Selection "C" on the matrix

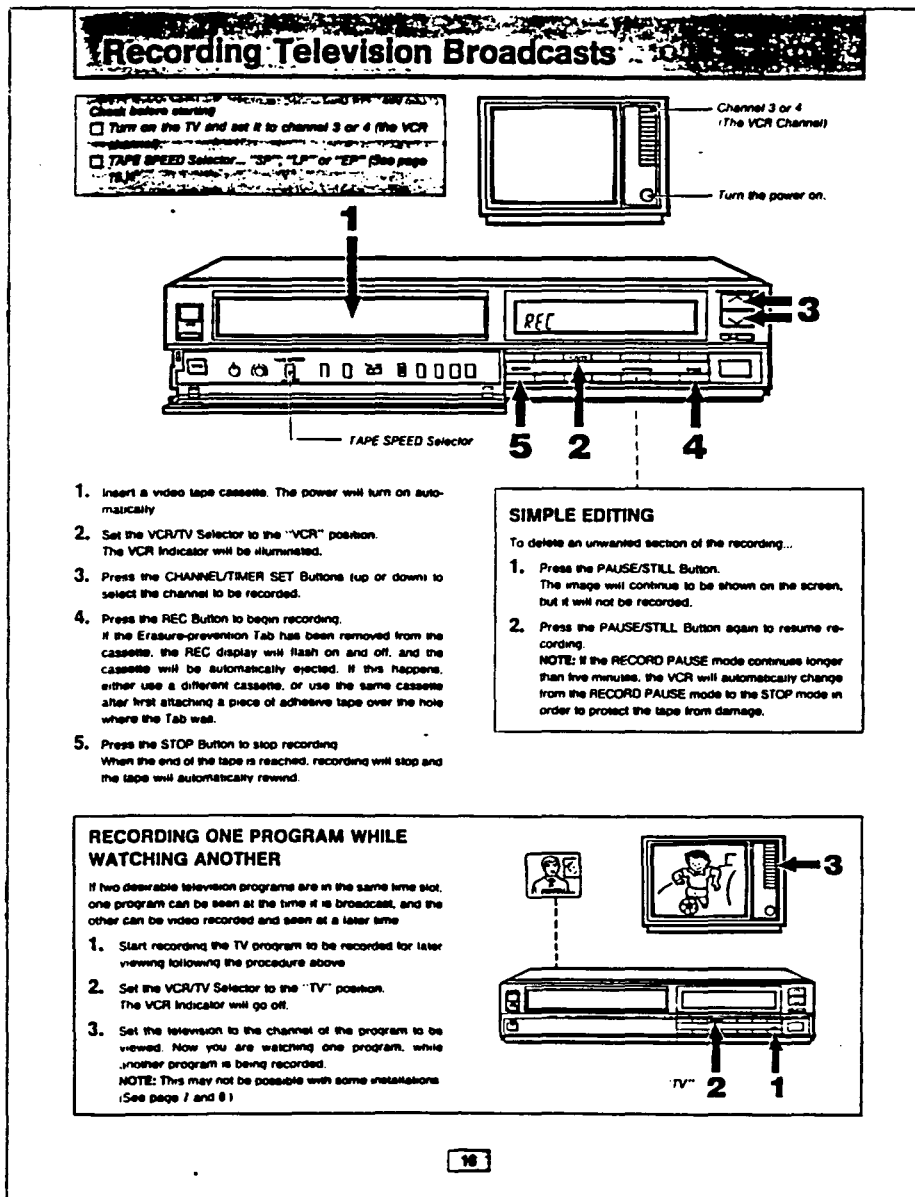

Figure 37. Recording Television Broadcasts section from the Sanyo manual. Selection "E" on the matrix

disorganized displays degraded the effectiveness of its communication. In addition, the one column display substantially exceeded the line width recommended for text material legibility. Finally, this manual did not follow the recommendation to use a serif typeface throughout the text material, instead it uses a light sans serif that makes for difficult reading.

The third manual was the Toshiba M-6100 (Figure 38). One of the graphic problems of this manual was that it did not follow a clear grid system throughout the design. Some sections use one column and others two columns with different line widths for the text matter. The one column text substantially exceeded the line width suggested for legibility.

This manual inconsistently placed subheadlines in the center of the text for some sections and on the left side for others. This created confusion in the information described and subtracted fluency from the text. In addition, an inefficient contrast between its text and subheadlines contributes to the lack of vitality.

One of the main problems of the GE 9-7450 manual was lack of consistency in page design display (Figure 39). The section examined showed different text locations for opposite pages. The left page displayed text matter in a lower position than the right one, contributing to difficulty in reading. This manual also used all uppercase italics for text matter; italics and all uppercase subtract legibility in text, according to the literature review. The lack of contrast among typographic elements makes a poor use of graphic vitality.

The last manual evaluated in this matrix was the Symphonic 7000 manual (Figure 40). This manual did not create clear illustration hierarchies. In addition, it used only partial illustrations without any general reference. This kind of design resolution creates confusion as to where the described parts belong. Also, all the illustrations were the same size without any visual contrast, contributing to a lack of graphic vitality. With no visual hierarchy

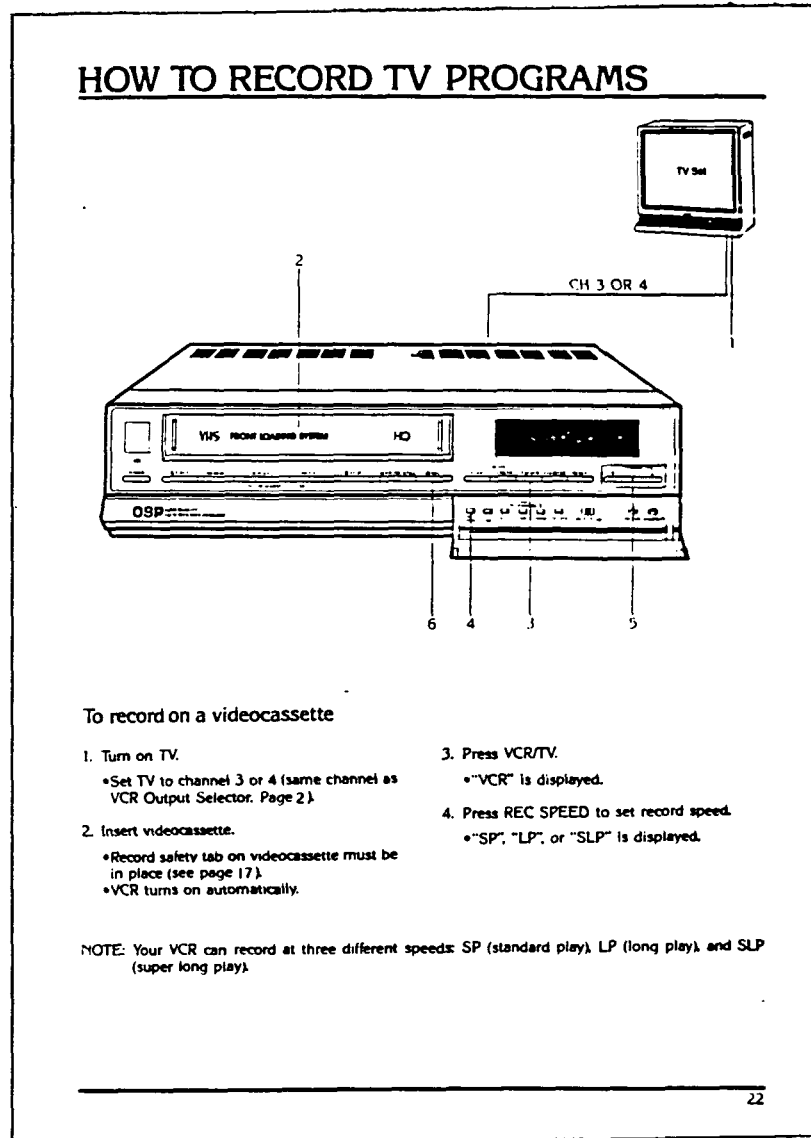
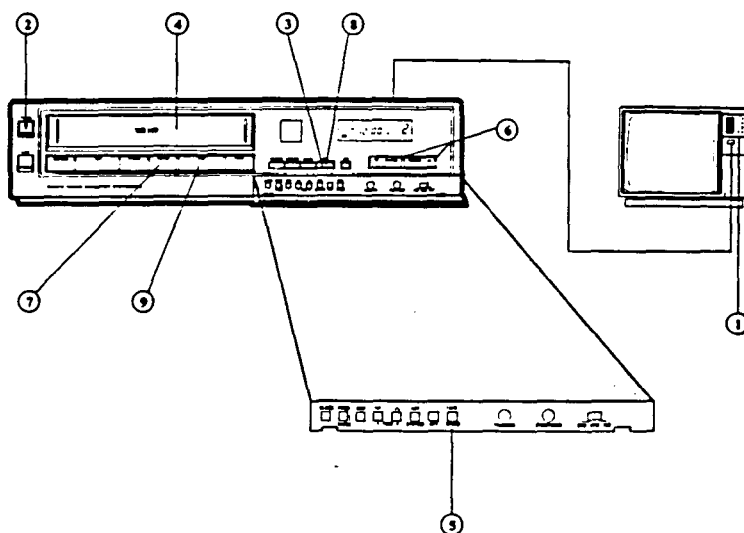

Figure 38. How to Record TV programs section from the Toshiba manual.
Selection "D" on the matrix

First Recording

This page gives the basic steps for recording. You should practice them until you can do them without referring to the manual. To save time, we suggest you record for only two or three minutes.

The following page shows you how to playback the recording you made.



- ① Turn on your TV and tune set to the "VCR channel" — channel 3 or 4 (same channel where the VCR output selector is set).
- ② Press the **VCR POWER** button (power indicator light will come on).
- ③ Press the **VCR/TV** switch until the letters "VCR" are displayed on the fluorescent display. The VCR is now in the VCR mode.
- ④ Insert a blank video cassette with the safety tab still intact.
- ⑤ Select the recording speed by pressing the **TAPE SPEED** button. Tape speed indicator (SP, LP, SLP) will appear on the fluorescent display. Use the SLP speed for normal recordings. It will give you the best results when using stop action and visible search.
- ⑥ Select the channel that you want to record by pressing either the **CHANNEL-UP** or **CHANNEL-DOWN** buttons.
- ⑦ Press the **RECORD** button to start recording.
- ⑧ You can turn your TV off during recording or you can press the **VCR/TV** switch so that the letters "TV" are displayed on the fluorescent display (TV mode). With the VCR in the "TV mode", you can watch a different channel by tuning the TV to the desired channel.
 Note: If your VCR is set to receive cable channels, "CATV" will appear on the display instead of "TV".
- ⑨ To end recording, press the **Stop** button. To pause during record operation, press the **PAUSE** button. To resume recording, press the **RECORD** button.

Figure 39. First Recording section from the G.E. manual.
Selection "B" on the matrix

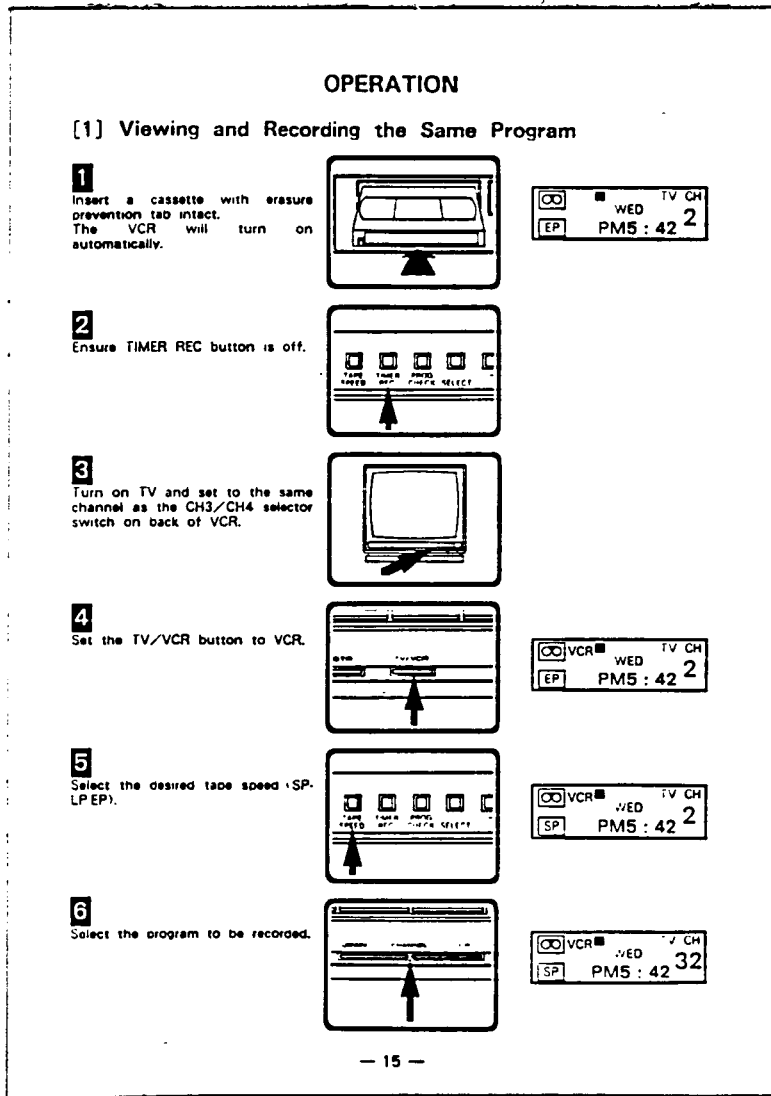

Figure 40. Viewing and recording the same program section from the Symphonic manual. Selection "A" on the matrix

among them, all illustrations were placed within the same range of importance. Finally, this manual used a light sans serif typeface for the text matter, which lacked legibility.

In general terms, the manual for Sony SLV-70HF followed the rules of legibility, as well as the formats for technical manuals described in the previous literature review more closely than the others. However, it did exhibit the following inadequacies according to the standards of legibility and technical format display derived from an analysis of the literature on the subject; lack of legibility in text matter; no clear difference between headlines and text; inadequate line widths; inconsistency in design display; inappropriate use of bold faces; and an incoherence in the general disposition of the elements. This is the selection of the manual.

INTRODUCTION TO THE PROJECT

The project involves the redesign of a portion of the selected manual. Three parts and the cover of the original manual were chosen to be redesigned, incorporating the results of the author's research into legibility and better page display design. The manual chosen was that of the Sony SLV-70HF Stereo Video Cassette Recorder. The portions chosen for redesign were: Precautions, Features, Recording TV Programs, and the cover. Because technical writing was not a consideration of this thesis, the text of the original three sections and the cover remain unaltered.

After making several sketches of the cover and the three sections using the standards which were developed, the entire project was done on the Apple Macintosh computer where more detailed sketches were produced until the final layouts were completed. For the development of the final layouts, a grid system and a "criteria of design" based on the evaluation matrix were implemented for the whole project.

The project is presented in two parts guided by diverse, though related, goals. The first part deals with experimentation, exploration, and understanding different approaches to design, including typography and its variations, typography and the use of visual punctuation, and the relationship of type to image to achieve visual vitality.

Through these explorations and the literature review the author decided on several important areas to consider for the further development of the project. First, serif typeface in text matter makes a good relationship with bold sans-serif typeface in the headlines and this relationship increases legibility; this is the issue of contrast to create vitality. Second, the use of black squares, as visual punctuation, improves the general functionalism of the typographic displays by allowing the eye to easily key on the information. And third, the

interaction between images and typography contributes to make the information more easy to understand because of the visual and verbal reinforcement involved.

The second part of the project synthesizes the results of the previous visual explorations to develop a unique format, implementing a grid system for the three sections and the cover. In order to accomplish this, a composite of the preliminary design explorations was produced. The goal was to redesign functional graphic displays for the sections selected (and the cover) in an harmonic way by following the rules of legibility in typography described in the literature review and by establishing order among graphic components with the use of a grid system. Vitality was an issue that was also addressed through the use of contrast and layout.

Several steps were involved in the design of the three selected sections (and cover) of the Sony SLV-70HF manual. The first step involved deciding the most appropriate format for this particular project. Because this kind of publication concerns logical description of procedures, a mathematical proportion for the basic format was chosen: 8.5-by-10.5 inch. The spread page, that seen by the user when reading, is thus 17-by-10.5 inch — which is the proportion of the golden section. This format permits a good positive-negative space relationship. In addition, it provides the advantages of a three column grid, selected by this author because it allows the manipulation of typography and images in two different proportions convenient for this design. In addition, this grid design allows the chosen text size to be set into a line width appropriate for legibility.

The second decision was to work exclusively with only one color on white paper. Because the complexity of color in communication was not researched in this study, only black and its derivatives (percentages of black) were used for this project.

The last decision was to use a computer for almost the entire creative process. Taking advantage of this technology allowed the preliminary sketches, typography experiments, and full size roughs to be displayed in good quality. Thus better decisions could be made because all elements in the design were present in their real size and in their real form, just as in the final display.

Redesign of the Sony Manual

All information relevant to this creative process for the three sections and the cover were taken from the original Sony SLV-70HF (Figure 41). Original text and illustrations were retained without modification; experimentation involved only the design layout. Although a brief investigation of technical writing was done in this study, this author does not consider himself an expert in this field, so the original text was retained without modification. In working out the basic format and concept, several preliminary sketches of each section were made to formulate layout ideas (Figure 42). A series of draft displays for each section was examined so as to experiment with different layout ideas to achieve effective communication.

To create vitality, a different design approach was applied to each section of the manual in this sketch process. The section on “Precautions” concentrated on experimentation with typography and its variations of size, style, and position; the “Features” section focused on experimentation with typography and visual punctuation (dots, squares, or lines to emphasize the meaning of the message); and the “Recording TV programs” section dealt with typography and image relationship (how well these two graphic elements work together, including the space around them — positive-negative relationship). Through explorations with typography, this author has concluded that the combination of serif typeface and bold sans-serif in headlines makes an appropriate blend

Recording TV Programs

I10

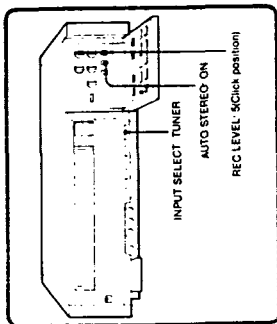

Before Recording I10

Caution
 Television programs, films, video tapes and other materials may be copyrighted. Unauthorized recording of such material may be contrary to the provisions of the copyright laws. Also, use of this recorder with cable television transmission may require authorization from the television transmitter and/or program owner.

- Make sure that you have finished all the connections and adjustments on pages 16 through 34.
- Check the positions of the selectors.

I11

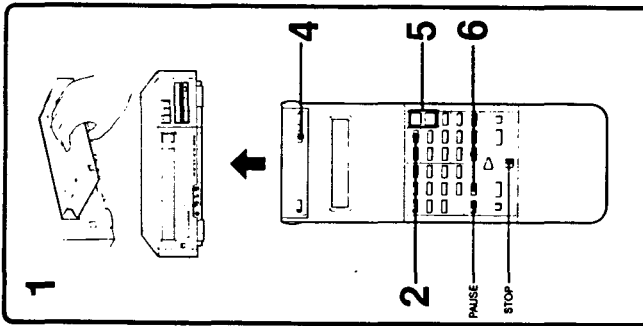

Recording I11

- 1 Insert a cassette. The unit is automatically turned on (Auto power on).
- 2 Select the recording speed, SP or EP, with REC MODE.
- 3 Turn on the TV and select the channel for the VCR or 4. If your TV has audio/video inputs, select the VCR input on the TV.
- 4 Press AMT TV/WTR so that the VTR indicator lights.
- 5 Select the channel to be recorded with CHANNEL +/-.
- 6 Press the recording auxiliary button while pressing ● REC. Recording begins.

To stop the tape momentarily
 Press II PAUSE. The TV program can still be seen on the TV, but the picture will not be recorded.
 To resume recording, press II PAUSE again.

To stop recording
 Press STOP.

When the tape reaches its end
 The tape will be returned to the beginning and the power of the unit remains on.

40

41

Figure 42. Original Sony displays for the three sections and the cover

Precautions	Features
<p>On safety</p> <ul style="list-style-type: none"> • Operate the unit only on 120V AC, 60Hz. • Should any thing into the cabinet, unplug the unit and have it checked by qualified personnel before operating it any further. • One blade of the plug is wider than the other for the purpose of safety and will fit into the power outlet only one way. If you are unable to insert the plug fully into the outlet, contact your dealer. • Unplug the unit from the wall outlet if it will not to be used for an extended period of time. To disconnect the cord, pull it out by the plug. Never pull the cord itself. <p>On installation</p> <ul style="list-style-type: none"> • Allow adequate air circulation to prevent internal heat build-up. • Do not place the unit on surfaces (rugs, blankets, etc) or near materials (curtains, drapes) that may block the ventilation. • Do not install the unit near heat sources such as radiators or air ducts or in a place subject to direct sunlight, excessive dust, mechanical vibration or shock. • The unit is designed for operation in a horizontal position. Do not install it in an inclined position. • Keep the unit and cassette tapes away from equipment with strong magnets, as for example a microwave oven or a large loudspeaker. • Do not place any heavy object on the unit. <p>On operation</p> <ul style="list-style-type: none"> • When the unit is not in use, turn the power off to conserve energy and to extend its useful life. • Remove and store video cassettes after recording or playback. • Store the cassettes in their cases and keep them in an upright position to prevent intrusion of dust and uneven winding. 	<p>On cleaning</p> <p>Clean the cabinet, panel and controls with a dry soft cloth, or a soft cloth slightly moistened with a mild detergent solution. Do not use any type of solvent, such as alcohol or benzene, which might damage the finish.</p> <p>On repacking</p> <p>Do not throw away the carton and packing materials. They make an ideal container in which to (re)store the unit. When shipping the unit to another location, repack it as illustrated on the carton.</p> <p>If you have any questions about this unit, contact your Sony service facility.</p>
<p>On automatic play menu</p> <p>You can select the various tape running modes with the auto menu.</p> <p>Program list</p> <p>You can see the TV programs set for timer-activated recording as a glance.</p> <p>P in P (picture in picture)</p> <p>You can watch a small TV picture inset in a VCR playback picture and vice versa.</p>	<p>Distinguished Editing Functions</p> <p>Edit monitor function</p> <p>You can monitor the editing process at a glance as both the picture and the edit mark and the one being recorded are simultaneously displayed on the connected TV or monitor.</p> <p>Input connections located on the front</p> <p>This allows you to use a video camera recorder easily.</p> <p>Flying erase head</p> <p>Color streaks and blurs which were conventionally caused by continuous recording or insert editing are eliminated with this head.</p>
<p>Auto (automatic play) menu</p> <p>You can select the various tape running modes with the auto menu.</p> <p>Program list</p> <p>You can see the TV programs set for timer-activated recording as a glance.</p> <p>P in P (picture in picture)</p> <p>You can watch a small TV picture inset in a VCR playback picture and vice versa.</p>	<p>Display Functions</p> <p>Tape transport information displayed</p> <p>You can see the information of the tape counter, tape speed and remained tape length on the TV monitor as the data screen.</p> <p>Blue background function*</p> <p>The VCR automatically paints the background in blue when the following items are displayed on the data screen so that you can read the data easily.</p> <ul style="list-style-type: none"> • EDIT MONITOR screen • Program list • Auto menu • Timer title
<p>Multi-function wireless commander with the liquid-crystal display</p> <p>You can control timer recordings easily with this commander.</p> <p>Timer recordings of eight TV programs over a month</p> <p>You can preset eight recordings of TV programs as much as one month in advance.</p>	<p>Convenient Functions</p> <p>Index search and index scan</p> <p>You can locate a desired program easily by marking the beginning of the program with an INDEX signal.</p> <p>High-quality picture</p> <p>This VCR provides sharp, finely detailed pictures through High Quality (HQ) picture technology.</p> <p>HQ The Video Cassette Recorder (VCR) with this marking incorporates VHS high-quality picture technology and is compatible with any Video Cassette Recorders bearing the VHS mark.</p>
<p>On background</p> <p>The background becomes blue in the following situations:</p> <ul style="list-style-type: none"> • when you select a channel and zoom • when a recorded tape or a tape portion without a CTL signal is played back • when an antenna is not connected • when the TV signal is weak • when the TV picture is being blanked • when the TV picture is being blanked from the LINE IN 1 or 2 jack • when an assignment is connected there • when noise and noise appear on the picture 	<p>On safety</p> <p>Operate the unit only on 120V AC, 60Hz.</p> <p>Should any thing into the cabinet, unplug the unit and have it checked by qualified personnel before operating it any further.</p> <p>One blade of the plug is wider than the other for the purpose of safety and will fit into the power outlet only one way. If you are unable to insert the plug fully into the outlet, contact your dealer.</p> <p>Unplug the unit from the wall outlet if it will not to be used for an extended period of time. To disconnect the cord, pull it out by the plug. Never pull the cord itself.</p> <p>On installation</p> <p>Allow adequate air circulation to prevent internal heat build-up.</p> <p>Do not place the unit on surfaces (rugs, blankets, etc) or near materials (curtains, drapes) that may block the ventilation.</p> <p>Do not install the unit near heat sources such as radiators or air ducts or in a place subject to direct sunlight, excessive dust, mechanical vibration or shock.</p> <p>The unit is designed for operation in a horizontal position. Do not install it in an inclined position.</p> <p>Keep the unit and cassette tapes away from equipment with strong magnets, as for example a microwave oven or a large loudspeaker.</p> <p>Do not place any heavy object on the unit.</p> <p>On operation</p> <p>When the unit is not in use, turn the power off to conserve energy and to extend its useful life.</p> <p>Remove and store video cassettes after recording or playback.</p> <p>Store the cassettes in their cases and keep them in an upright position to prevent intrusion of dust and uneven winding.</p>

Figure 42 (continued)

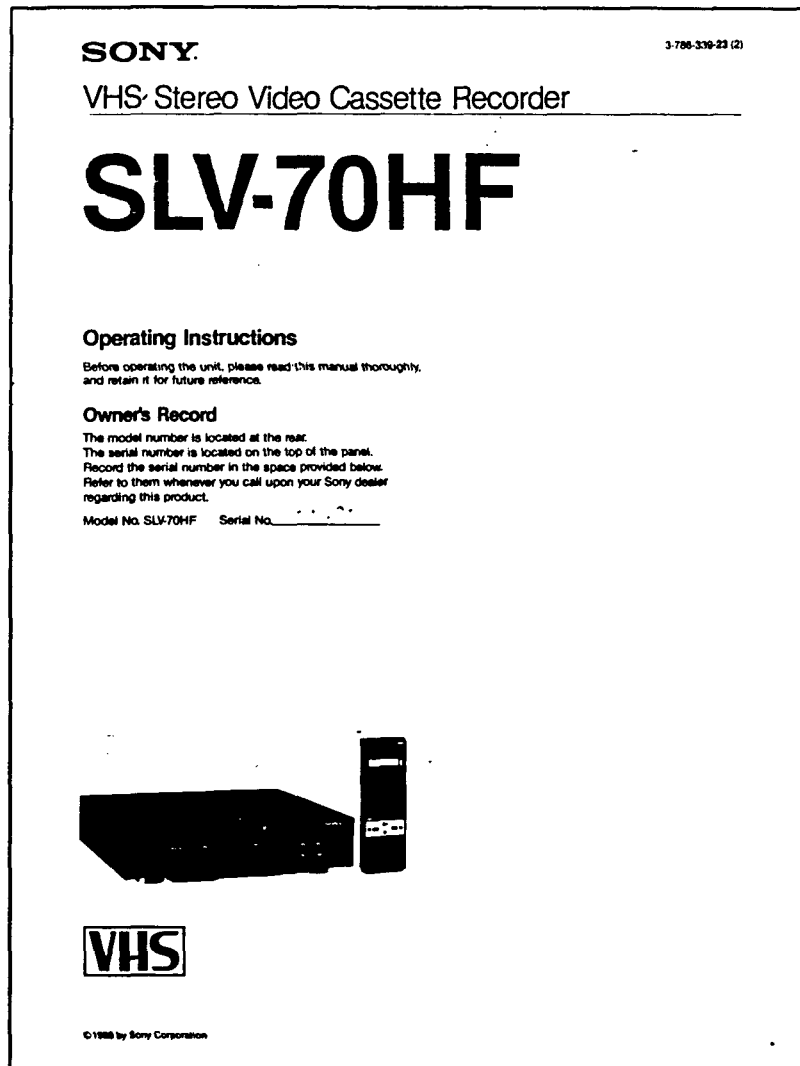
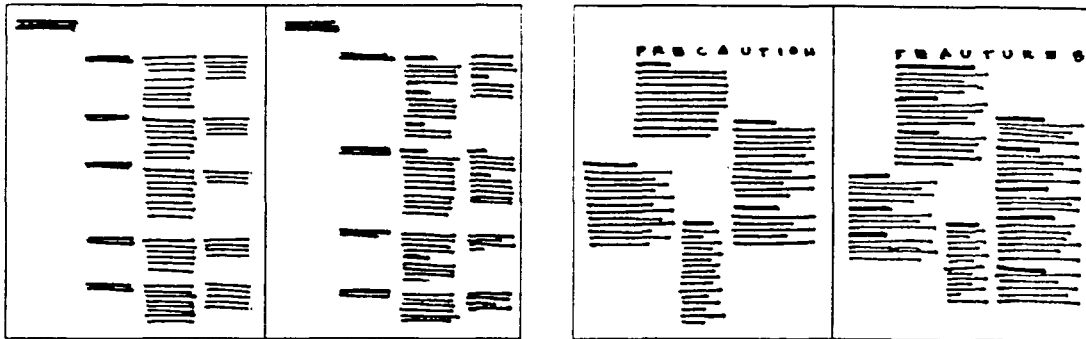
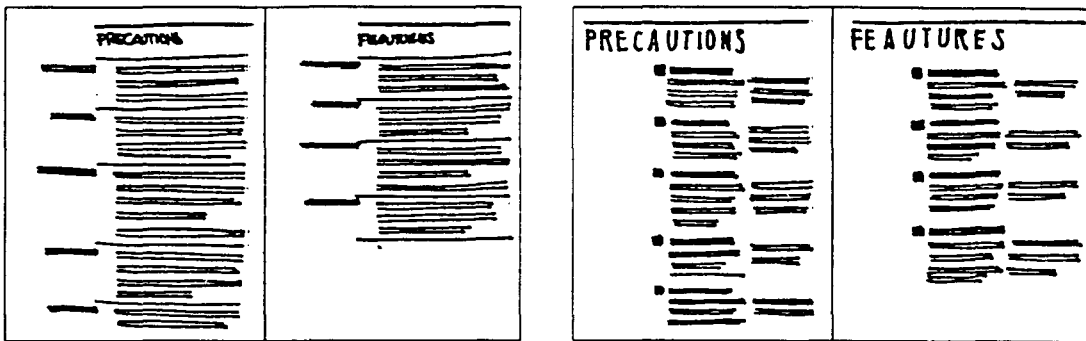

Figure 42 (continued)



Typography and its variations



Typography and visual punctuation

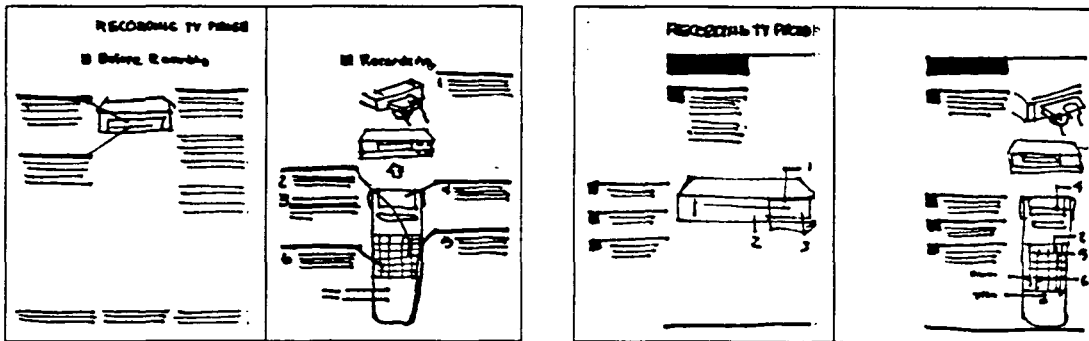

Typography and image relationship

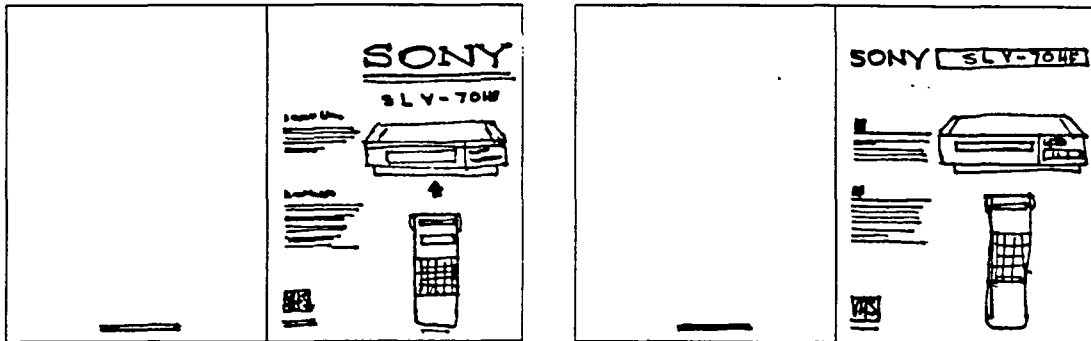

Typography and image relationship

Figure 42. Preliminary sketches for each section and the cover.
Part 1 of the redesign process

which increases legibility; however, further tests would be necessary for this to be conclusive. Moreover, typography and visual punctuation such as dots, squares, or numbers definitely marks an improved visual flow and hierarchy in the written material. But it is through the combination of typography and image that information can be clarified the most.

After analysing the preliminary sketches, more detailed ones were developed for the Precaution and Features sections using a variety of positions and several grid ideas to see different alternatives for the design. Because these two sections were adjacent to one another in the original manual, the relationship between them was also examined (Figure 43). At this point the role of typography was not examined very closely, but the hierarchy of the message was sketched in a clear way. After deciding on some alternative approaches to design (those close to the research in legibility and format design), the next part of the process was to use the computer to generate layouts and create output for analysis.

The use of computer typography in different variations allowed this author to see relationships of size, style, and position in several ways and thus make a better decision about the final design. The principles relevant to legibility of types were major factors in making the final design decisions. Goudy stated that “legibility requires proper contrast not only in the types themselves, but also in their arrangement upon the page” (1940, p. 132). The previous approaches to design for both sections were explored in the computer environment, combining different types, sizes, positions, styles (bold, italics, leading, word space) as well as the relationship of typography to visual punctuation (Figure 44).

In the "Recording" section, the inclusion of illustrations allowed for new alternatives of design to be explored. A set of four outlined illustrations (having the standard quality required in this kind of technical material) were taken from the original manual. As

P R E C A U T I O N				F E A T U R E S			
Softy	[Redacted]	[Redacted]	[Redacted]	Delayed Editing Function	[Redacted]	[Redacted]	[Redacted]
Installation	[Redacted]	[Redacted]	[Redacted]	Delayed Function	[Redacted]	[Redacted]	[Redacted]
Operation	[Redacted]	[Redacted]	[Redacted]	Compact Function	[Redacted]	[Redacted]	[Redacted]
Cleaning	[Redacted]	[Redacted]	[Redacted]	High Quality Paper	[Redacted]	[Redacted]	[Redacted]
Repair	[Redacted]	[Redacted]	[Redacted]	[Redacted]	[Redacted]	[Redacted]	[Redacted]

<i>Precautions</i>		<i>Features</i>	
• [Redacted]	[Redacted]	• [Redacted]	[Redacted]
• [Redacted]	[Redacted]	• [Redacted]	[Redacted]
• [Redacted]	[Redacted]	• [Redacted]	[Redacted]
• [Redacted]	[Redacted]	• [Redacted]	[Redacted]
• [Redacted]	[Redacted]	• [Redacted]	[Redacted]
• [Redacted]	[Redacted]	• [Redacted]	[Redacted]
• [Redacted]	[Redacted]	• [Redacted]	[Redacted]
• [Redacted]	[Redacted]	• [Redacted]	[Redacted]
• [Redacted]	[Redacted]	• [Redacted]	[Redacted]
• [Redacted]	[Redacted]	• [Redacted]	[Redacted]

Figure 43. Sketches for the Precautions and the Features sections.
Part 1 of the redesign process

features

High-quality Picture
The VCR provides clear, high-resolution picture through high (H) picture technology. With the Video Cassette Recorder (VCR) with the modern microcomputer VHS high-quality technology and a computer with the Video Cassette Recorder becomes the VHS unit.

Display Functions
Auto luminance play mode: You can select the various tone control modes with the auto mode. Program fast forward: You can set the TV to stop at a certain point of a video P in P function to program. You can watch a small TV picture with a VCR playback screen and a video. Tape transport information display: You can see the information of the tape counter, tape speed and residual tape length on the TV monitor as the data screen. Still background function: Still CR automatically opens the background in blue when the following items are displayed on the video screen so that you can read the data easily.
Program list
Auto menu
Timer still

Distorted/Editing Functions
Edit master function: You can know the editing process of a picture on both the picture being copied and the one recorded in a continuously-rewound on the connected TV or monitor. Hypercompression: Based on the best technology to use a video cassette recorder, audio frequency band color stretch and which were conventionally cleared. Hypercompression recording is most often an element with the best. Background editing with a Sony VCR: Hypercompression function: You can control the VCR continuously. Editing: Digital 8 equalized audio equalization, push forward reverse control the tape transport of another Sony video unit by using this unit.

Convenient Functions
Multi function remote: Automatically the input output function. You can control your VCR through the remote. Your recording through TV program with a multi function remote. You can control TV program such as an advance before established video search. You can locate individual program search by marking the beginning of the program with an INDEX signal.

Features

The VCR provides clear picture through High (H) picture technology. With the Video Cassette Recorder (VCR) with the modern microcomputer VHS high-quality technology and a computer with the Video Cassette Recorder becomes the VHS unit.

Display Functions
Auto luminance play mode: You can select the various tone control modes with the auto mode. Program fast forward: You can set the TV to stop at a certain point of a video P in P function to program. You can watch a small TV picture with a VCR playback screen and a video. Tape transport information display: You can see the information of the tape counter, tape speed and residual tape length on the TV monitor as the data screen. Still background function: Still CR automatically opens the background in blue when the following items are displayed on the video screen so that you can read the data easily.
Program list
Auto menu
Timer still

Distorted/Editing Functions
Edit master function: You can know the editing process of a picture on both the picture being copied and the one recorded in a continuously-rewound on the connected TV or monitor. Hypercompression: Based on the best technology to use a video cassette recorder, audio frequency band color stretch and which were conventionally cleared. Hypercompression recording is most often an element with the best. Background editing with a Sony VCR: Hypercompression function: You can control the VCR continuously. Editing: Digital 8 equalized audio equalization, push forward reverse control the tape transport of another Sony video unit by using this unit.

Convenient Functions
Multi function remote: Automatically the input output function. You can control your VCR through the remote. Your recording through TV program with a multi function remote. You can control TV program such as an advance before established video search. You can locate individual program search by marking the beginning of the program with an INDEX signal.

P R E C A U T I O N S

ON USAGE
Operate the unit on 120V AC, 60Hz. Should any thing into the cabinet, unplug the unit and have a check of by-qualified personnel before opening it any further.
Open inside of the plug or under the cover for the purpose of safety and will fit into the power outlet only one way. If you are unable to insert the plug fully into the outlet, contact your dealer.
Unplug the unit from the wall outlet if it will not be used for an extended period of time. To disconnect the cord, pull it by the plug. Never pull the cord itself.

ON INSTALLATION
After the system or installation is completed, do not pull the unit up. Do not place the unit on unstable things, shelves, etc.) or over unstable furniture, equipment that may block the ventilation slots. Do not install the unit in hot rooms such as bedrooms or in places subject to direct sunlight, overheat, or mechanical vibration or shock.
This unit is designed for operation in a horizontal position. Do not install it in an unusual position. Keep the unit and connect tapes away from equipment with strong magnets, and so example a microwave oven or a large transformer. Do not place any heavy object on the unit.

ON DISASSEMBLY
When the unit is not in use, turn the power off all accessories energy and so avoid an accident.
Disconnect and stored in a safe place. Do not work on playback. Should the cassette in it or tape and keep it as an original program to prevent corruption or short and overwriting.

IF YOU HAVE ANY QUESTION ABOUT THIS UNIT, CONTACT YOUR SONY SERVICE FACILITY.

P R E C A U T I O N S

On safety
Operate the unit on 120V AC, 60Hz. Should any thing into the cabinet, unplug the unit and have a check of by-qualified personnel before opening it any further.
Open inside of the plug or under the cover for the purpose of safety and will fit into the power outlet only one way. If you are unable to insert the plug fully into the outlet, contact your dealer.
Unplug the unit from the wall outlet if it will not be used for an extended period of time. To disconnect the cord, pull it by the plug. Never pull the cord itself.

On installation
After the system or installation is completed, do not pull the unit up. Do not place the unit on unstable things, shelves, etc.) or over unstable furniture, equipment that may block the ventilation slots. Do not install the unit in hot rooms such as bedrooms or in places subject to direct sunlight, overheat, or mechanical vibration or shock.
This unit is designed for operation in a horizontal position. Do not install it in an unusual position. Keep the unit and connect tapes away from equipment with strong magnets, and so example a microwave oven or a large transformer. Do not place any heavy object on the unit.

On operation
When the unit is not in use, turn the power off all accessories energy and so avoid an accident.
Disconnect and stored in a safe place. Do not work on playback. Should the cassette in it or tape and keep it as an original program to prevent corruption or short and overwriting.

On cleaning
Clean the cabinet, panel and controls with a dry soft cloth, or with a cloth slightly moistened with a mild detergent solution.
Do not spray any type of cleaning solution directly on the unit.

On repacking
Do not throw away the carton and packing materials. They may be used in case of an accident to which the unit is subjected. When shipping the unit to another location, repack it in the original carton.

IF YOU HAVE ANY QUESTIONS ABOUT THIS UNIT, CONTACT YOUR SONY SERVICE FACILITY.

Figure 44. Approaches of design for the Precautions and the Features sections. Application of computer technology to the part 1 of the redesign process

Anderson (1987) points out: “one of the best ways to make your visuals persuasive and easy to use is to make them simple and uncluttered” (p. 388). The next step was to amplify them and retouch them, using traditional tools such as black ink and white correction fluid, to obtain illustrations of better quality (Figure 45). After selecting the sketches for this section, the retouched illustrations were digitized with a scanner to a Tiff file and imported into the computer. Free manipulation of the images was now available; images could be reduced or enlarged to any size and moved to any position on the page. As in the previous sections, typographic information was imported into the computer and, along with the illustrations, manipulated in different ways (Figure 46). Although these steps were exploratory, in every case a grid system was used to help emphasize clarity and functionalism — two important factors for the final layouts. The use of the grid system in this step allowed organization of all graphic elements in a structured and well-balanced way.

The cover was developed to include all the original elements: the brand name, the model of the VCR, the VHS trademark, and illustrations. Different alternatives, including variations of illustrations and brand name, were explored following a grid system (Figure 47). The last step in this experimentation was to design the best option by combining approaches which closely followed the rules of legibility, order, and vitality for the whole manual.

Specifications and justifications

The margin proportions for each page were: left-hand page at the top with 1 inch; bottom with 3/4 inch; left margin with 3/4 inch and the right with 1 3/8 inch. The right margin is wide enough to compensate the deformation produced on a page by the binding.

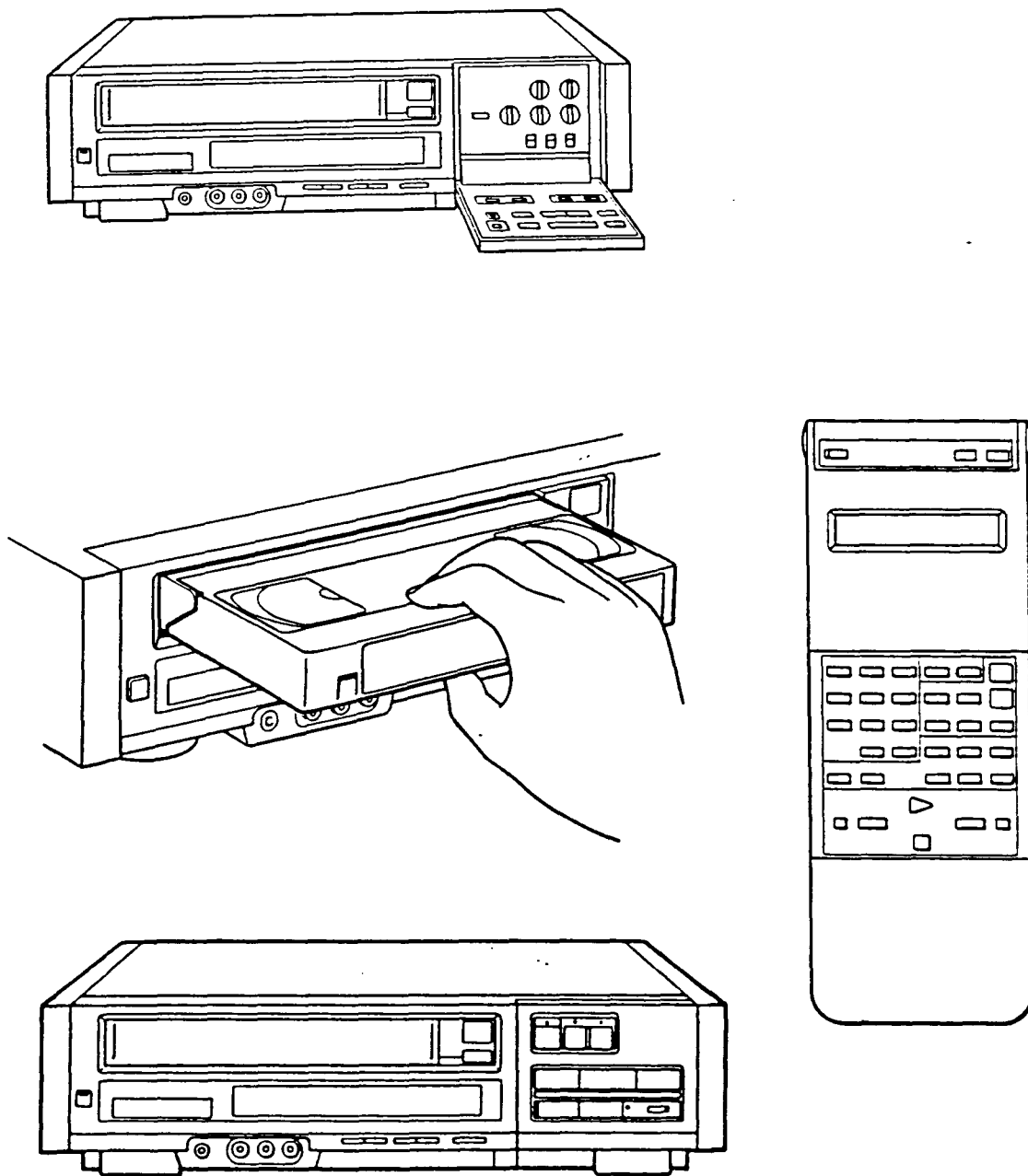

Figure 46. Drawings taken from the original manual and scanned

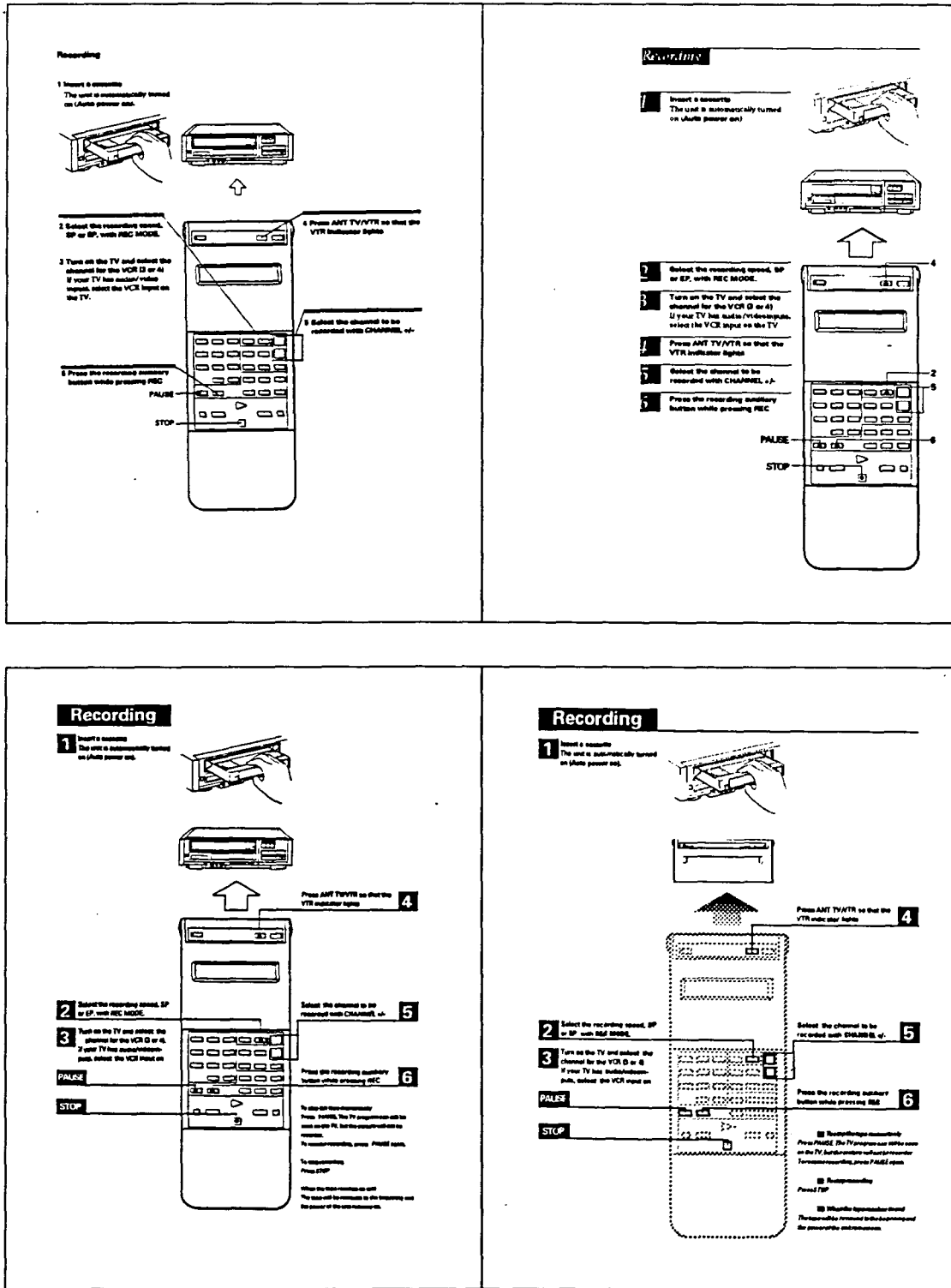





Figure 46. Preliminary displays for the Recording TV programs section. Application of computer technology to the part 1 of the redesign process

SONY. SLV-70HF
VHS STEREO VIDEO CASSETTE RECORDER

Operating Instructions
Before operating the unit, please read the manual thoroughly, and retain it for future reference.



Owner's Record
The model number is located at the rear.
The serial number is located on the top of the panel.
Record the serial number in the space provided below.
Refer to those who have you sold when you buy.
Some dealers require this product.
Model No. SLV-70HF Serial No. _____



SONY. SLV-70HF
VHS STEREO VIDEO CASSETTE RECORDER

Operating Instructions
Before operating the unit, please read the manual thoroughly, and retain it for future reference.

Owner's Record
The model number is located at the rear.
The serial number is located on the top of the panel.
Record the serial number in the space provided below.
Refer to those who have you sold when you buy.
Some dealers require this product.
Model No. SLV-70HF Serial No. _____

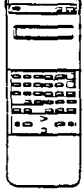
SONY. SLV-70HF
VHS STEREO VIDEO CASSETTE RECORDER

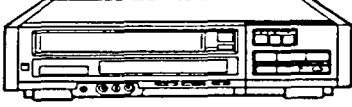
VHS

Operating Instructions
Before operating the unit, please read the manual thoroughly, and retain it for future reference.

Owner's Record
The model number is located at the rear.
The serial number is located on the top of the panel.
Record the serial number in the space provided below.
Refer to those who have you sold when you buy.
Some dealers require this product.
Model No. SLV-70HF Serial No. _____

SONY.
VHS Stereo Video Cassette Recorder
SLV-70HF

Operating Instructions
Before operating the unit, please read the manual thoroughly, and retain it for future reference.

Owner's Record
The model number is located at the rear.
The serial number is located on the top of the panel.
Record the serial number in the space provided below.
Refer to those who have you sold when you buy.
Some dealers require this product.
Model No. SLV-70HF Serial No. _____

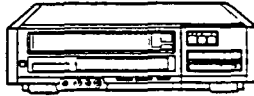
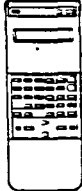



Figure 47. Preliminary displays for the cover.
Application of computer technology to the part 1 of the redesign process

Margins with different sizes add variety to the whole page design and contribute to establishing an asymmetric design. The right-hand page has identical, but opposite proportions.

A three column grid per page was used in order to place the text in the correct line width according to its size, and to integrate headlines and illustrations in an objective and functional way. With these guides, the size of each pictorial element was modified according to its importance to the subject (Figure 48).

One of the advantages of using a grid system is that it allows orderliness of design. As Muller-Brockmann (1981) declared: “this orderliness adds credibility and confidence to the information displayed. In addition, the graphic communication presented in a clear and logical display will not only be read more quickly and easily but also will be better understood” (p. 13).

The typography used in the text was *Palatino* 9 point, selected for its clarity and harmony of form. In addition, this typeface has a strong serif and elegant proportions which contribute to its legibility. The typeface *Palatino* has all the characteristics of legibility as established in the matrix. In reading matter, a serif typeface is more readable than sans serif typeface. As Rehe (1974) points out: “serif typefaces in general seem to be more legible and are preferred by the readers over sans serif type” (p. 32).

The line width for this 9 point typeface was 24 picas, allowing about 12 words per line, a measure recommended by Rehe. The leading used for the text matter was 3 point, considered by Paterson/Tinker (1932) to be one of the most effective.

Headlines and sub-headlines were displayed in the *Futura bold* typeface in order to make a visual contrast with the text. This typeface was selected because its simple, geometric shapes make a clear contrast with the text, enhancing its legibility. *Futura* was

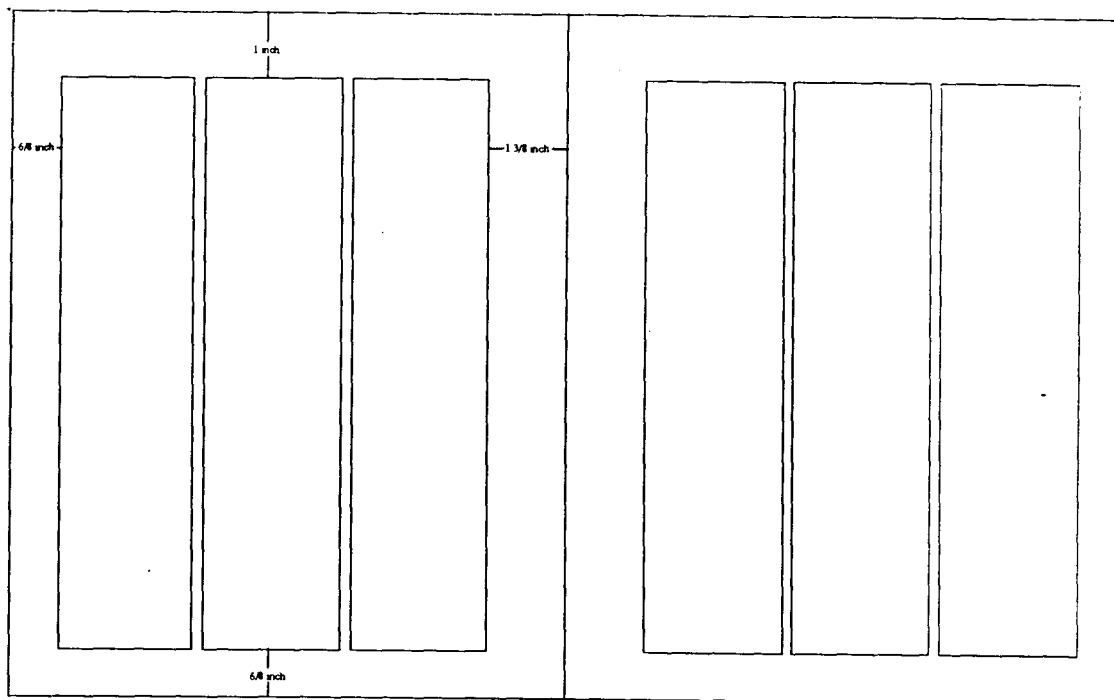

Figure 48. Grid display for the final layouts

also used to emphasize some descriptive steps in the Recording section. The use of bold typefaces in the midst of plain text helps readers to focus attention on specific instructions. Tinker (1955) reports: “for emphasis, bold face instead of italic should be used in text matter” (p. 31).

Each division of the “Precautions” and “Features” sections was divided by light lines in order to separate each area of information. In addition, visual punctuation was used to emphasize sub-headlines and details of importance (Figure 49). The same kind of visual punctuation was used through out the three sections, as well as on the cover.

In the “Recording TV programs” section the illustrations were placed according to the grid (Figure 50). The major illustrations were enlarged to show those points important to the instructions. The instruction steps for this section were highlighted with visual

Precautions	Features
<p>■ On safety</p> <ul style="list-style-type: none"> ⊗ Operate the unit on 120V AC 60Hz. ⊗ Should any plug into the cabinet, unplug the unit and have it checked by qualified personnel before operating it any further. ⊗ One blade of the plug is wider than the other for the purpose of safety and will fit into the power outlet only one way. If you are unable to insert the plug fully into the outlet, contact your dealer. ⊗ Unplug the unit from the wall outlet if it will not be used for an extended period of time. To disconnect the cord, pull it by the plug. Never pull the cord itself. <p>■ On installation</p> <ul style="list-style-type: none"> ⊗ Allow adequate air circulation to prevent internal heat build-up. Do not place the unit on surfaces (rugs, blankets, etc.) or near movable (curtains, draperies) that may block the ventilation slots. ⊗ Do not install the unit near heat sources such as radiators or air ducts or in places subject to direct sunlight, excessive dust, mechanical vibration or shock. ⊗ The unit is designed for operation in a horizontal position. Do not install it in an inclined position. ⊗ Keep the unit and cassette tapes away from equipment with strong magnets, as for example a microwave oven or a large loudspeaker. ⊗ Do not place any heavy object on the unit. <p>■ On operation</p> <ul style="list-style-type: none"> ⊗ When the unit is not in use, turn the power off to conserve energy and to prevent its use as a fire hazard. ⊗ Do not use the unit's video cassette slot recording or playback. ⊗ Store the cassettes in their cases and keep them in an upright position to prevent intrusion of dust and uneven winding. <p>■ On cleaning</p> <ul style="list-style-type: none"> ⊗ Clean the cabinet, panel and controls with a dry soft cloth, or soft cloth lightly moistened with a mild detergent solution. ⊗ Do not use any type of solvent such as alcohol or benzene, which might damage the finish. <p>■ On packing</p> <ul style="list-style-type: none"> ⊗ Do not throw away the carton and packing materials. They make an ideal container in which to repackage the unit. When shipping the unit to another location, repack it as illustrated on the carton. <p style="text-align: right;">If you have any questions about this unit, contact your Sony service facility.</p>	<p>■ Distinguished editing functions</p> <p>Take over the live broadcast</p> <p>You can take over the editing process as a viewer as soon as the picture being played back on the monitor. The recorded picture is simultaneously displayed on the connected TV or monitor.</p> <p>Input comments learned on this front</p> <p>This allows you to use a video camera recorder easily.</p> <p>Color streaks and blurs which were conventionally caused by continuous recording or inserting editing are eliminated with this head.</p> <p>Synchronized editing with a stereo VCR equipped as optional</p> <p>You can connect this set to the connected VCR simultaneously during editing. Color streaks and blurs which were conventionally caused by continuous recording or inserting editing are eliminated with this head.</p> <p>Color streaks and blurs which were conventionally caused by continuous recording or inserting editing are eliminated with this head.</p> <p>⊗ Program list</p> <p>You can select the various tape running modes with the auto menu.</p> <p>Program list</p> <p>You can set the TV programs set for time-shared recording at plan.</p> <p>⊗ Play</p> <p>You can watch a small TV picture inserted in a VCR playback picture and vice versa.</p> <p>⊗ Tape transport information displayed</p> <p>You can see the information of the tape counter, tape speed and remaining tape length on the TV monitor as the data screen.</p> <p>Blue back-ground function</p> <p>The VCR automatically paints the background in blue when the following happens on the data screen so that you can read the data easily.</p> <ul style="list-style-type: none"> ⊗ EDIT MODE screen ⊗ Program list ⊗ Timer title <p>■ Convenient functions</p> <p>Multi-function window commander with the liquid-crystal display</p> <p>You can control user recordings easily with this commander.</p> <p>⊗ Timer recording of eight TV programs over a month</p> <p>Three preset eight recordings of TV programs as much as one month in advance.</p> <p>Index search and index scan</p> <p>You can locate a desired program easily by marking the beginning of the program with an INDEX signal.</p> <p>■ High-quality picture</p> <p>The VCR provides sharp, finely detailed picture through High Quality HQ The Video Camera Recorder (VCR) with dual tracking progressive VHS high-quality picture technology and is compatible with any Video Cassette Recorder bearing the VHS mark.</p>
4	5

Figure 49. Final display for Precautions and Features sections

punctuation, as Andrews (1975) recommends for technical manuals to improve searching, scanning, and reading.

The cover was displayed in a manner following the same grid system of the three sections (Figure 51). As in the other sections, a visual hierarchy of the graphic elements was implemented. Futura bold and Palatino typefaces were used to achieve visual harmony with the rest of the manual design. The only exception was the line “VHS Stereo Video Cassette Recorder” for which Futura condensed was used in order to balance with the brand. In this case, the use of bold typeface would unbalance the relationship with the brand name because it is a larger line than the brand name. On the other hand, the “SLV-70 HF” line was framed with a rectangle of 20 percent black in order to fit with the rest of the typographic elements and with the style of the whole manual. The rectangle also serves as a standard area for any model number. The typographic information was placed in the two right columns leaving the left column for headlines, cautions, and white space.

The new manual design is better than the original because it is based on the principles of legibility, functional structure, adequate typography, and is consistent through out the entire design. The goal of this design was, as Ladislav Sutnar declared: “to make information easy to find, read, comprehend, and recall” (cited in Meggs, 1983, p. 374).

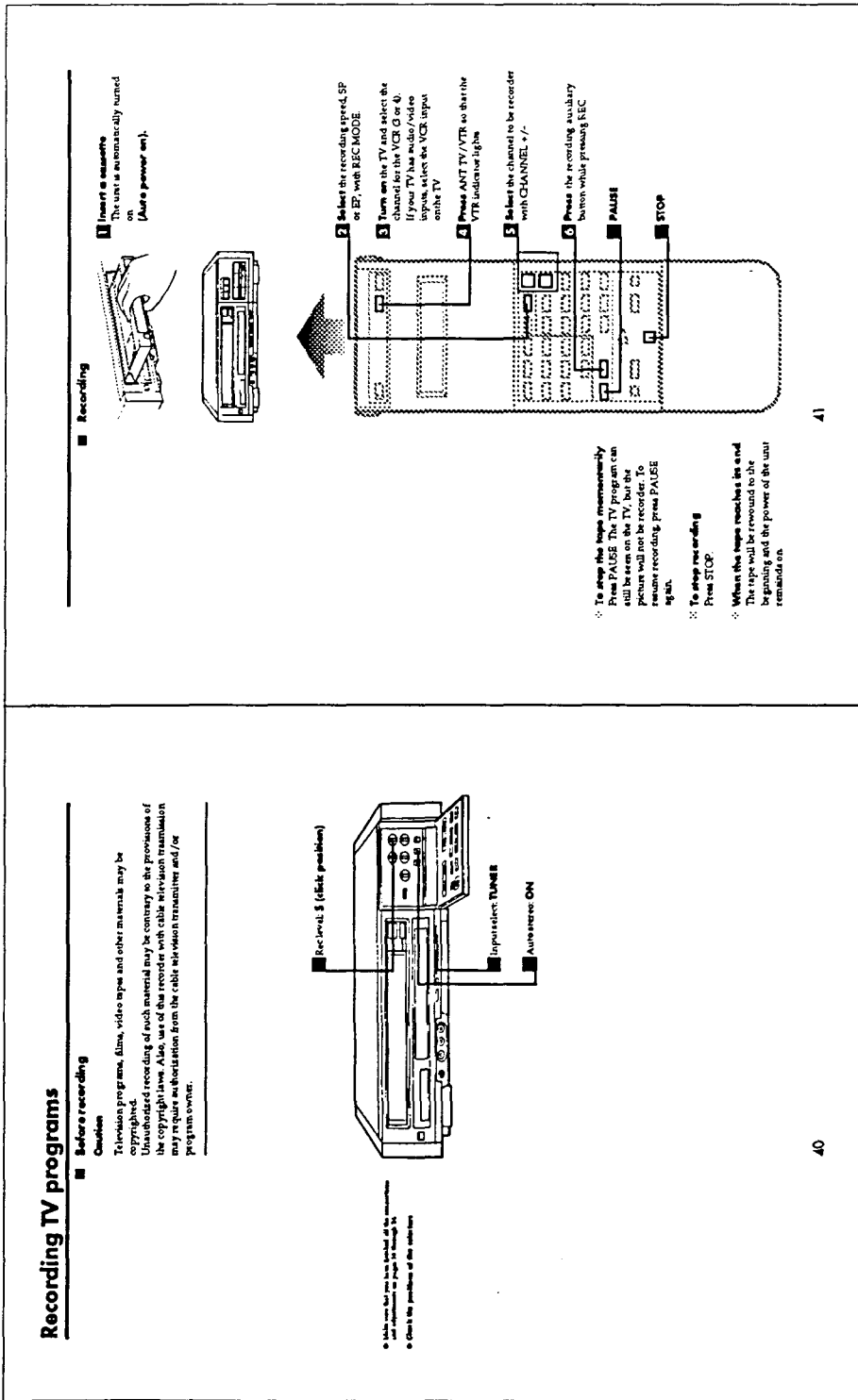



Figure 50. Final display for Recording TV Programs section

SONY.

SLV70HF

VHS STEREO VIDEO CASSETTE RECORDER



VHS

- **Operating Instructions**
Before operating the unit, please read the manual thoroughly, and retain it for future reference.
- **Owner's Record**
The model number is located at the rear. The serial number is located at the top of the panel. Record the serial number in the space provided below. Refer to them whenever you call upon your Sony dealer regarding this product.
Model No. **SLV70HF** Serial No. _____

© 1982 Sony Corp.
Printed in Japan

Figure 51. Final display for the cover

CONCLUSIONS

Technical manuals are the interface between the user and technology. Their graphic displays must be highly focused and clear so that communication and vitality can stimulate interest and visually reinforce the message. Technical manuals are printed media concerned with complex information, such as descriptions of processes and operation instructions. A clear description of this information, as well as an interesting and functional display, should be the major goals of the graphic designer.

In this society, new electronic products are produced every day, some with more complex operating systems than others; all manuals must instruct users on proper operation, care, and maintenance. Technical manuals play an important role in the transmission of this kind of complex information. Detailed descriptions of procedures must show users how to interact with the new product, how to operate each feature, and how to resolve possible problems.

Communicating technical information is important in our society because the hardware and software of electronics are very complex and the information is often obtuse and not easily accessed. Technical manuals are often the first contact between the user and the new product. Without this kind of communication the transmission of procedures for new products would be practically impossible.

The design of technical manuals should be guided by two important graphic principles: order and vitality. Although order and vitality play important roles in the development of graphic communication in general, in technical manuals they are essential. Order, which is achieved through an organizing structure and a consistency of typographic format throughout the entire manual, brings communication clarity — the major factor in the

efficient transmission of complex information. Vitality, realized through varied typography, asymmetric layouts, and a sense of spontaneity, stimulates interest and visually reinforces the message — important factors in the description of procedures that are not the most exciting reading for most people.

The information in technical manuals is basically used by those who can afford to buy electronic products, or those who are exposed to electronic items in the work place. The majority of these people are adults who are mainly interested in learning how to operate a new electronic product. Studies indicate that functional information and simple, friendly displays are the elements that these people are looking for when they open a new technical manual.

Functional information and simple friendly displays were important factors in the development of a new design for the Sony VHS Stereo Cassette Recorder SLV-70HF instruction manual. With these two factors in mind, the goal was to achieve a functional manual through the consistent use of an organizing structure, legible typographic displays, and a selection of appropriate typography. Visual reinforcement of the message was achieved through the use of typographic contrast, asymmetric layout, and simple visuals.

In the future, technical manuals will play an important role in the transmission of directions and instructions since they are the materials reviewed every time a question arises. A large number of technical manuals today lack visual usefulness because they do not follow the rules of legibility, order and vitality. For example, the original Sony SLV-70 HF instruction manual was mainly concerned with the transmission of directions without paying much attention to the norms of legibility, functionalism in display, visual vitality, and harmony through its pages. The goal of the new design was to improve all these deficiencies through a more functional and user friendly interface.

A further step in this thesis should be the testing and evaluation of the redesign for effective communication. It is worth mentioning at this point to acknowledge that the proof of this thesis cannot be considered conclusive without further testing and evaluation by a user group.

People will continue to want to have a reference manual to create a sense of security in knowing information is available. With technology accelerating faster than technological literacy people will continue to rely on understandable and user friendly technical manuals to operate the equipment of today and tomorrow.

BIBLIOGRAPHY

- Anderson, Paul V. *Technical Writing*. San Diego: Harcourt Brace Jovanovich, Publishers, 1987.
- Andrews, Clarence A. *Technical and Business Writing*. Boston: Houghton Mifflin Corporation, 1975.
- Bayer, Herbert. *Herbert Bayer Painter, Designer, Architect*. New York: Reinhold Publishing Corporation, 1967.
- Courthion, Pierre. *Impressionism*. New York: Harry N. Abrams, Inc., Publishers, 1964.
- De Stijl, 1917-1931: Vision of Utopia*. Phaidon, Oxford: Mildred Friedman, Editor, 1982.
- Denuir, Bernard. *Impressionism*. Woodbury, New York: Barron's, 1978.
- Dreyfuss, Henry. *Symbol Source Book: An Authoritative Guide to International Graphic Symbols*. New York: McGraw-Hill Book Company, 1972.
- Goudy, Frederic. *Typologia: Studies in type design & type making*. Berkeley: University of California Press, 1940, 77.
- General Electric. *Owner's Manual, Video Cassette Recorder 9-7450*. Korea: 1987.
- Gottschall, Edward M. *Typographic Communications Today*. Cambridge, Massachusetts and London, England: The MIT Press, 1989.
- Holmes, Nigel and De Neue, Rose. *Designing Pictorial Symbols*. New York: Watson-Guptill Publications, 1985.

- Hurlburt, Allen. *The Grid: A Modular System for the Design and Production of Newspapers, Magazines, and Books*. New York: Van Nostrand Reinhold Company, 1978.
- Kelder, Diane. *Great Masters of French Impressionism*. New York: Crown Publishers, Inc., 1978.
- Lewis, John. *The 20th Century Book: Its Illustration and Design*. New York: Van Nostrand Reinhold Company, 1967.
- Meggs, Philip B. *Type and Image*. New York: Van Nostrand Reinhold Company, 1989.
- Meggs, Philip B. *A History of Graphic Design*. New York: Van Nostrand Reinhold Company, 1983.
- Minolta Corporation. *T-770S Owner's Manual-E*. Japan.
- Modley, Rudolf. *Handbook of Pictorial Symbols*. New York: Dover Publications, Inc., 1976.
- Muller-Brockmann, Josef. *Grid Systems in Graphic Design: A Visual Communication Manual For Graphic Designers, Typographers, and Three Dimensional Designers*. New York: Hastings House Publishers, 1981.
- Neurath, Otto. *Modern Man In The Making*. New York: Alfred A. Knopf, 1939.
- Rehe, Rolf F. *Typography: How To Make It Most Legible*. Carmel, Indiana: Design Research International, 1974.
- Rüegg, Ruedi. *Basic Typography: Design with Letters*. New York: Van Nostrand Reinhold, 1989.

Sanyo Electric Inc. *Instruction Manual VHR 3350*. Japan.

Sony Corporation. *VHS Stereo Video Cassette Recorder SLV-70HF*. Japan: 1988.

Symphonic Corporation. *Owner's Manual Video Cassette Recorder 7000*. Japan.

Toshiba America, Inc. *Owner's Manual, Video Cassette Recorder M-6100*. Korea

Walker Art Center. *Russian Constructivism: Art Into Life 1914-1932*. New York: Rizzoli, 1990.

Wingler, Hans M. *The Bauhaus*. Cambridge, Massachusetts and London, England: The MIT Press, 1986.